

# TELEDYNE ANALYTICAL INSTRUMENTS



- Bidirectional RS-232 for remote operation
- Adaptive signal filtering optimizes response time

## PRINCIPLE OF OPERATION

Teledyne's GFC-7002E measures low ranges of nitrous oxide by comparing infrared energy absorbed by a sample to that absorbed by a reference according to the Beer-Lambert law. This is accomplished with a Gas Filter wheel which alternately allows a high energy light source to pass through a N<sub>2</sub>O filled chamber and a chamber with no N<sub>2</sub>O present.

The light path then travels through the sample cell, which has a folded path of 2.5 meters. The energy loss through the sample cell is compared with the zero reference signal provided by the gas filter to produce a signal proportional to concentration, with little effect from interfering gases within the sample.

## MODEL GFC-7002E Gas Filter Correlation N<sub>2</sub>O Analyzer

### ADVANCED PERFORMANCE

This design produces excellent zero and span stability and a high signal to noise ratio, allowing extreme sensitivity. Multi-tasking software gives real time indication of numerous operating parameters and provides automatic alarms if diagnostic limits are exceeded.

Built-in data acquisition and internal memory allows logging multiple parameters, including average and instantaneous values, calibration data, and operating parameters. Up to 8,000 records of stored data may be retrieved via the RS-232 port or from the front panel. The Model GFC-7002E features rugged construction and is designed to perform with a minimum of attention. In the event maintenance is required, modular construction makes service a simple operation.

### APPLICATIONS

The GFC-7002E is ideally used as a safety monitor for accumulation of solubalized N<sub>2</sub>O in oxygen and breakthrough of N<sub>2</sub>O from particular mole sieves in the air supply associated with cryogenic air separation equipment that features particular reboiler designs. It can also be used to monitor the N<sub>2</sub>O used for food processing propellant purposes as well as for semiconductor manufacturing oxidizer use (i.e. high purity applications).

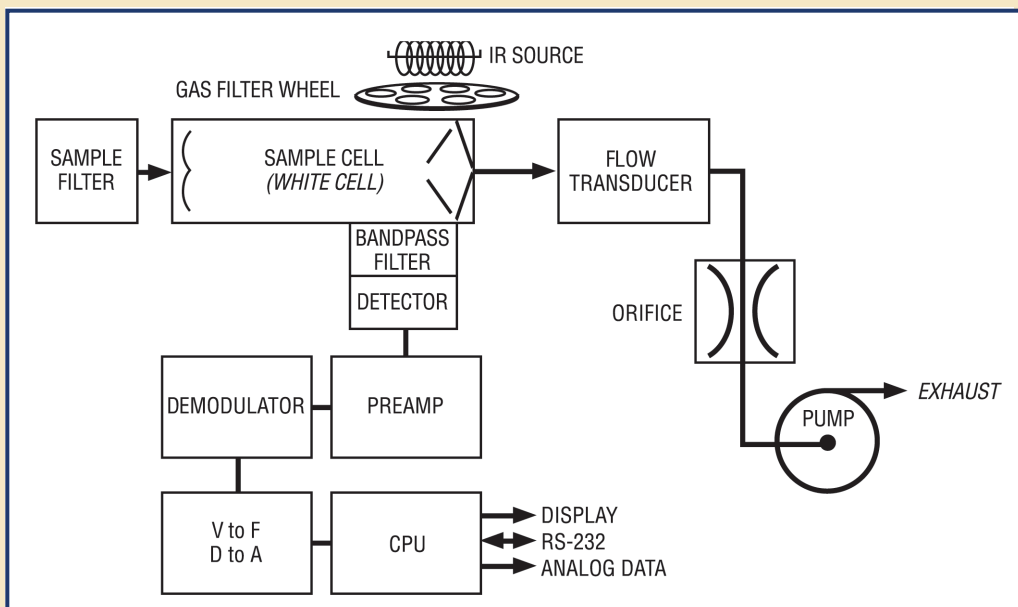

**Built for Reliability and Performance**

# Model GFC-7002E Specifications

<b>Ranges:</b>	0-1 ppm to 0-1000 ppm full scale, user selectable
<b>Units:</b>	Dual ranges and auto ranging supported ppm, mg/m <sup>3</sup>
<b>Zero noise:</b>	<0.02 ppm (RMS)
<b>Span noise:</b>	<0.5% of reading (RMS)
<b>Lower detectable limit (LDL):</b>	0.04 ppm
<b>Zero drift:</b>	< 0.1 ppm/24 hours, < 0.2 ppm/7 days
<b>Span drift:</b>	< 1% of reading/7 days
<b>Rise and fall time:</b>	<60 seconds to 95%
<b>Linearity:</b>	1% full scale
<b>Precision:</b>	0.5% of reading
<b>Sample flow rate:</b>	800 cc/min ± 10%
<b>Operating temp range:</b>	5 - 40°C
<b>Dimensions:</b>	7" (178 mm) x 17" (432 mm) x 23.5" (597 mm)
<b>Weight:</b>	40 lbs (18.0 kg)
<b>Power:</b>	100V - 120V, 220V - 240V, 50/60 Hz, 250W
<b>Analog outputs:</b>	10V, 5V, 1V, 100mV, selectable
<b>Recorder offset:</b>	±10%
<b>Serial outputs:</b>	Serial Port 1: RS-232, DB-9M Serial Port 2: standard RS-232 or optional RS-485, DB-9F, Ethernet
<b>Status (digital):</b>	8 outputs, 6 inputs (opto-isolated), 4 alarm outputs (optional)
<b>Current output:</b>	Optional 4-20mA
<b>Approvals:</b>	CE

**Interferences:** H<sub>2</sub>O, CO<sub>2</sub>; negligible  
\* At constant temperature and voltage

## CONFIGURATIONS

- Selectable voltage
- Internal pump
- 10 isolated digital status outputs
- Bi-directional RS-232
- 2 optoisolated alarm outputs
- Supported voltages:

100V / 50Hz	100V / 60Hz
115V / 60Hz	220V / 50Hz
220V / 60Hz	230V / 50Hz (CE)
240V / 50Hz	
- Output voltage:

10V	5V
1V	100mV
- Particulate filter: 47mm

## OPTIONS

- "U" version - 0-10 ppm and lower ranges
- Rack mount (19") with chassis slides
- Rack mount only
- Isolated 0-20mA or 4-20mA output
- Multi-drop RS-232 connection
- Calibration valves
- Stainless steel valves for selection of customer-supplied zero and span gas

## ACCESSORIES

- RS-232 cable
- Expendables kit
- Spare parts kit

## TELEDYNE ANALYTICAL INSTRUMENTS

A Teledyne Technologies Company

16830 Chestnut Street  
City of Industry, California 91748, USA

TEL: 626-934-1500 or 888-789-8168

FAX: 626-934-1651 EMAIL: ask\_tai@teledyne.com

[www.teledyne-ai.com](http://www.teledyne-ai.com)

## Warranty

Instrument is warranted for 1 year against defects in material or workmanship

NOTE: Specifications and features will vary with application. The above are established and validated during design, but are not to be construed as test criteria for every product. All specifications and features are subject to change without notice.

