OPERATING INSTRUCTIONS FOR

LXT-280

Dissolved Oxygen Transmitter



P/N M

ECO:



DANGER



Toxic gases and or flammable liquids may be present in this monitoring system.
Personal protective equipment may be required when servicing this instrument.
Hazardous voltages exist on certain components internally which may persist for a time even after the power is turned off and disconnected.
Only authorized personnel should conduct maintenance and/or servicing.
Before conducting any maintenance or servicing, consult with authorized supervisor/manager.

Copyright © 2006 Teledyne Instruments/ Analytical Instruments

All Rights Reserved. No part of this manual may be reproduced, transmitted, transcribed, stored in a retrieval system, or translated into any other language or computer language in whole or in part, in any form or by any means, whether it be electronic, mechanical, magnetic, optical, manual, or otherwise, without the prior written consent of Teledyne Instruments/ Analytical Instruments, 16830 Chestnut Street, City of Industry, CA 91749-1580.

Warranty

This equipment is sold subject to the mutual agreement that it is warranted by us free from defects of material and of construction, and that our liability shall be limited to replacing or repairing at our factory (without charge, except for transportation), or at customer plant at our option, any material or construction in which defects become apparent within one year from the date of shipment, except in cases where quotations or acknowledgements provide for a shorter period. Components manufactured by others bear the warranty of their manufacturer. This warranty does not cover defects caused by wear, accident, misuse, neglect or repairs other than those performed by TI/AI or an authorized service center. We assume no liability for direct or indirect damages of any kind and the purchaser by the acceptance of the equipment will assume all liability for any damage which may result from its use or misuse.

We reserve the right to employ any suitable material in the manufacture of our apparatus, and to make any alterations in the dimensions, shape or weight of any parts, in so far as such alterations do not adversely affect our warranty.

Important Notice

This instrument provides measurement readings to its user, and serves as a tool by which valuable data can be gathered. The information provided by the instrument may assist the user in eliminating potential hazards caused by his process; however, it is essential that all personnel involved in the use of the instrument or its interface, with the process being measured, be properly trained in the process itself, as well as all instrumentation related to it.

The safety of personnel is ultimately the responsibility of those who control process conditions. While this instrument may be able to provide early warning of imminent danger, it has no control over process conditions, and it can be misused. In particular, any alarm or control systems installed must be tested and understood, both as to how they operate and as to how they can be defeated. Any safeguards required such as locks, labels, or redundancy, must be provided by the user or specifically requested of TI/AI at the time the order is placed.

Therefore, the purchaser must be aware of the hazardous process conditions. The purchaser is responsible for the training of personnel, for providing hazard warning methods and instrumentation per the appropriate standards, and for ensuring that hazard warning devices and instrumentation are maintained and operated properly.

Teledyne Instruments/ Analytical Instruments, the manufacturer of this instrument, cannot accept responsibility for conditions beyond its knowledge and control. No statement expressed or implied by this document or any information disseminated by the manufacturer or its agents, is to be construed as a warranty of adequate safety control under the user's process conditions.

Specific Model Information

Instrument Serial Number: _____

Instrument Range: _____

Calibrated for: _____

Safety Messages

Your safety and the safety of others is very important. We have provided many important safety messages in this manual. Please read these messages carefully.

A safety message alerts you to potential hazards that could hurt you or others. Each safety message is associated with a safety alert symbol. These symbols are found in the manual and inside the instrument. The definition of these symbols is described below:



GENERAL WARNING/CAUTION: Refer to the instructions for details on the specific danger. These cautions warn of specific procedures which if not followed could cause bodily Injury and/or damage the instrument.



CAUTION: HOT SURFACE WARNING: This warning is specific to heated components within the instrument. Failure to heed the warning could result in serious burns to skin and underlying tissue.



WARNING: ELECTRICAL SHOCK HAZARD: Dangerous voltages appear within this instrument. This warning is specific to an electrical hazard existing at or nearby the component or procedure under discussion. Failure to heed this warning could result in injury and/or death from electrocution.



Technician Symbol: All operations marked with this symbol are to be performed by qualified maintenance personnel only.

No
Symbol

NOTE: Additional information and comments regarding a specific component or procedure are highlighted in the form of a note.



CAUTION: THE ANALYZER SHOULD ONLY BE USED FOR THE PURPOSE AND IN THE MANNER DESCRIBED IN THIS MANUAL.



IF YOU USE THE ANALYZER IN A MANNER OTHER THAN THAT FOR WHICH IT WAS INTENDED, UNPREDICTABLE BEHAVIOR COULD RESULT POSSIBLY ACCOMPANIED WITH HAZARDOUS CONSEQUENCES.

This manual provides information designed to guide you through the installation, calibration operation and maintenance of your new process controller. Please read this manual and keep it available.

Occasionally, some instruments are customized for a particular application or features and/or options added per customer requests. Please check the front of this manual for any additional information in the form of an Addendum which discusses specific information, procedures, cautions and warnings that may be peculiar to your instrument.

Manuals do get lost. Additional manuals can be obtained from TI/AI at the address given in the Appendix. Some of our manuals are available in electronic form via the internet. Please visit our website at: www.teledyne-ai.com.

Table of Contents

List of Figures	viii
List of Tables	ix
Introduction	1
1.1 Overview	1
1.2 Main Features of the Transmitter	2
1.3 Optional Features	2
1.4 Front Panel	2
1.5 Model Identification	4
Installation	5
2.1 Unpacking the Instrument	5
2.2 Mounting	5
2.3 Wiring	7
2.3.1 Site Wiring	7
2.3.2 Power Wiring	7
2.3.3 Sensor Wiring	8
2.3.4 DC Power	8
2.4 Configuring the LXT-280	9
2.5 Calibration	9
Operation	11
3.1 Using the Front Panel Keys	11
3.2 Menus	12
3.2.1 Contrast	13
3.2.2 Main Menu	14
3.2.3 Electrode Data Screen	14
3.2.4 Electrode Zero Menu	15
3.2.5 Electrode Span Menu	16

Dissolved Oxygen Transmitter

3.2.6 Output Calibration Menu	16
3.2.7 DO Locus	16
3.2.8 Temperature Calibration Menu	17
Calibration	19
4.1 Calibration	19
4.2 Manual Output Mode	19
4.3 Contrast Adjustment	20
4.4 Zero Calibration	21
4.5 Span Calibration	22
4.6 Automatic Buffer Calibration	24
4.7 Calibration Error Detection	24
4.8 Back-to-Factory Calibration	25
4.9 Output Calibration	26
4.10 Locus Calibration	27
4.11 Temperature Calibration	27
4.11.1 Temperature Adjustment	27
4.11.2 Temperature Calibration—Manual TC Adjustment	28
4.11.3 Temperature Units Calibration – °C/°F Conversion	29
Calibration Correction Factors	31
5.1 Calibration Correction Factors	31
5.2 Salinity Correction	34
5.3 Calibration Example	35
5.4 Grab Sample Calibration	35
5.5 Dissolved Oxygen Units of Measurement	36
Maintenance	37
6.1 Routine Maintenance	37
6.1.1 Cleaning	37
6.1.2 Replacement of the Microprocessor:	37
Appendix	41
A.1 Specifications	41
A.2 Spare Parts Listing	43
Index	45

List of Figures

Figure 1-1: LXT-280 User Interface	3
Figure 2-1: Typical Installation for the LXT-280 Transmitter.....	6
Figure 2-2: Intrinsically Safe Wiring Diagram	7
Figure 2-3: LXT-280 Wiring	8
Figure 3-1: LXT-280 Operator Interface.....	11
Figure 3-2: Available Menus	13

List of Tables

Table 5-1: Oxygen Saturation vs. Temperature32
Table 5-2: Relative Humidity Correction Factors33
Table 5-3: Elevation Correction Factor33
Table 5-4: Salinity Correction Factor34
Table 6-1: Troubleshooting38

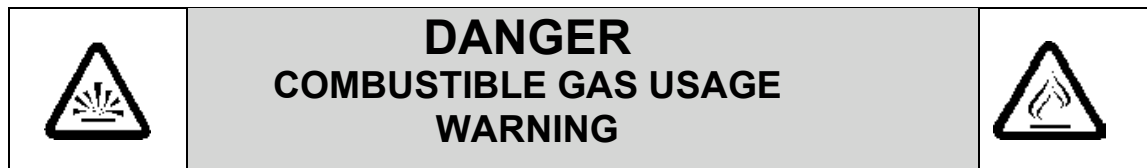

This instrument is Factory Mutual Approved as an intrinsically safe and explosion proof gas analyzer for use in Class I, II, and III Divisions 1 Groups A through G hazardous areas. This approval applies only to the equipment specified and installed in accordance with the information contained within this manual. It is the customer's responsibility to ensure safety especially when combustible gases are being analyzed since the potential of gas leaks always exist.

The customer should ensure that the principles of operating of this equipment is well understood by the user and that the instrument as well as any approved support equipment is properly installed. Misuse of this product in any manner, tampering with its components, or unauthorized substitution of any component may adversely affect the certification and the safety of this instrument.

Since the use of this instrument is beyond the control of Teledyne, no responsibility by Teledyne, its affiliates, and agents for damage or injury from misuse or neglect of this equipment is implied or assumed.

Introduction

1.1 Overview

Teledyne's Model LXT-280 Transmitter is a robust and versatile instrument for measurement and process control of dissolved oxygen. This instrument is Factory Mutual Approved as intrinsically safe and explosion proof for use in Class I, II, and III Divisions 1 Groups A through G hazardous areas. The Model LXT-280 transmitters provide solutions to a variety of liquid analytic applications involving hazardous areas. The LXT-280 accepts input from a variety of sensors for specific process measurements such as:

- Dissolved Oxygen (DO)
- pH
- Resistivity (or conductivity)
- Oxidation-Reduction Potential (ORP)
- Specific Ion

The standard instrument is powered from an external 24 VDC source and is equipped with a 4-20mA current output transmitted on the same 24 VDC wiring. The power supply and electronics are remote from each other and for FM approval, should be connected through an intrinsic safety barrier. Separate compartments in the stainless steel explosion proof housing keep the wiring and the electronics separate and sealed from each other. This prevents the sensitive electronics from being exposed to hostile environments.

The LXT-280 is housed in a Factory Mutual Approved explosion proof stainless steel NEMA-7C housing. The operator interacts with the instrument via magnetic switches located on the front panel behind a removable cover. The magnetic switches can be activated without having to open the cover.

This transmitter is capable of measuring dissolved oxygen in ppm or in the percent oxygen range.

1.2 Main Features of the Transmitter

The LXT-280 Transmitter for dissolved oxygen applications incorporates the following standard features:

- Magnetic switches located behind a glass window can be activated without having to open the instrument.
- Menu driven backlit display with contrast adjustment
- Automatic Calibration. This allows calibration points to be defined upon initialization of the transmitter.
- An easy back to factory calibration menu allows the instrument to return to a predetermined factory calibration. The default parameters are: zero electrode offset at 0 ppm or 0% oxygen and -400 mV at full scale.
- 4-20mA current output transmitted on the same 24 VDC power wiring. The current output is fully expandable to any range within the transmitter's full operating range. The current output can be configured to be reverse acting.
- Temperature Conversion. Temperature can be displayed in either Fahrenheit or Celsius. The units can be toggled from one to the other in the field with the conversion calculation performed automatically.

1.3 Optional Features

The Model LXT-280 Transmitter is a versatile instrument designed to meet the needs for liquid analytics and process control across a wide range of applications. Options available for this transmitter includes:

Optional Software

Security Access—keyboard security option: Allows only authorized personnel entry to calibration modes.

1.4 Front Panel

The operator interfaces with the instrument through a sight glass window using magnetically activated arrow keys. This is accomplished by touching an instrument magnet to the glass window directly over the

appropriate magnetic switch. The LXT-280 uses an "underline" cursor in each of the menus.

Figure 1-1 shows the user interface for the LXT-280 instrument. The interface includes the LCD display capable of outputting alphanumeric information in 2 rows of 16 characters per row and 4 magnetic switch arrow keys that control the operation of the unit.

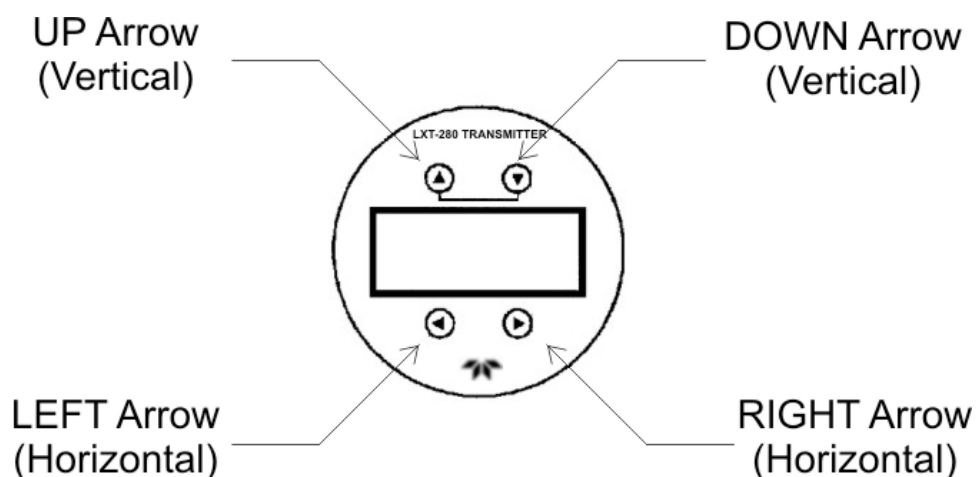

Figure 1-1: LXT-280 User Interface

The keys are in two groups:

VERTICAL UP/DOWN (▲/▼) Arrow Keys

- These keys are used to change the display menu.
- They also move the cursor vertically. Any menu can be accessed by magnetically activating the appropriate UP or DOWN key
- These keys also perform numeric adjustments to display values while in the calibrate mode. Magnetically activating the up vertical arrow key will increase the value or magnetically activating the down vertical arrow key will decrease the value.

HORIZONTAL LEFT/RIGHT (◀/▶) Arrow Keys

- The right and left arrows are used to enter the calibrate mode. To enter the calibrate mode, magnetically activate the right horizontal arrow key. Once in the calibrate mode, the cursor can be positioned by magnetically activating the right or the left horizontal arrow key. To exit the calibrate mode, magnetically activate left horizontal arrow key until the cursor is all the way to the left.
- These keys also move the cursor horizontally.

1.5 Model Identification

The LXT-280 Transmitter is a 24VDC unit. The instrument is configured at the factory for the customer's application and so there are many different model designators.

The following codes will help in identifying a specific instrument configuration.

Base Model:

LXT-280 LXT-280 Transmitter

Channel 1 Input with 4-20mA Output:

-DO/MA Dissolved Oxygen (specify ppm or %)
-PH/MA pH
-ORP/MA Oxidation Reduction Potential (REDOX)
-PION/MA Specific ion
-CD/MA Conductivity, 0-20 mS
-CDT/MA Conductivity Toroidal (form 50mA to 1S)
-RS/MA Resistivity (0 to 50 megohms)

Mounting Hardware:

-UM Universal mounting plate

Other Options:

KSx Keyboard Security Code (x = level of security, see Security Code Option)

Installation

Installation of the LXT-280 Transmitter involves:

- Unpacking the instrument
- Mounting
- Making Electrical Connections
- Configuring the Instrument
- Calibration

2.1 Unpacking the Instrument

The LXT-280 Transmitter has been carefully packaged to protect it from damage during shipment and dry storage. Upon receipt please follow the procedure outlined below:

1. Before unpacking, inspect the condition of the shipping container to verify proper handling by the carrier. If damage is noted, save the shipping container as proof of mishandling for the carrier.
2. Check the contents of the shipping container with the items and quantities shown on the packing list. Immediately report any discrepancies to TI/TAI.
3. Save the original packing material until you are satisfied with the contents. In the event the transmitter must be returned to the factory, the packing material will allow you to properly ship it to TI/TAI.
4. Familiarize yourself with the instrument before installation, and follow proper installation and wiring procedures.

2.2 Mounting

The LXT-280 transmitter can be wall mounted or pipe mounted. Installation drawings with dimensions are included at the back of this manual. The power supply must be located in a non-hazardous area while the transmitter and sensor can be installed in a hazardous

environment as shown in Figure 2-1. For intrinsically safe installation, an FM approved safety barrier must be installed between the power supply/receiver and the transmitter as shown in Figure 2-2.

CAUTION: USE ONLY FM APPROVED SAFETY BARRIERS. CONTACT TELEDYNE FOR A LIST OF FM APPROVED INTRINSIC SAFETY BARRIERS FOR YOUR APPLICATION.



If mounting hardware is ordered with the instrument, it has been factory assembled and the LXT-280 is ready for mounting. A sunshade should be considered during the selection of the mounting location this prevents direct sunlight from creating an oven effect inside of the enclosure.

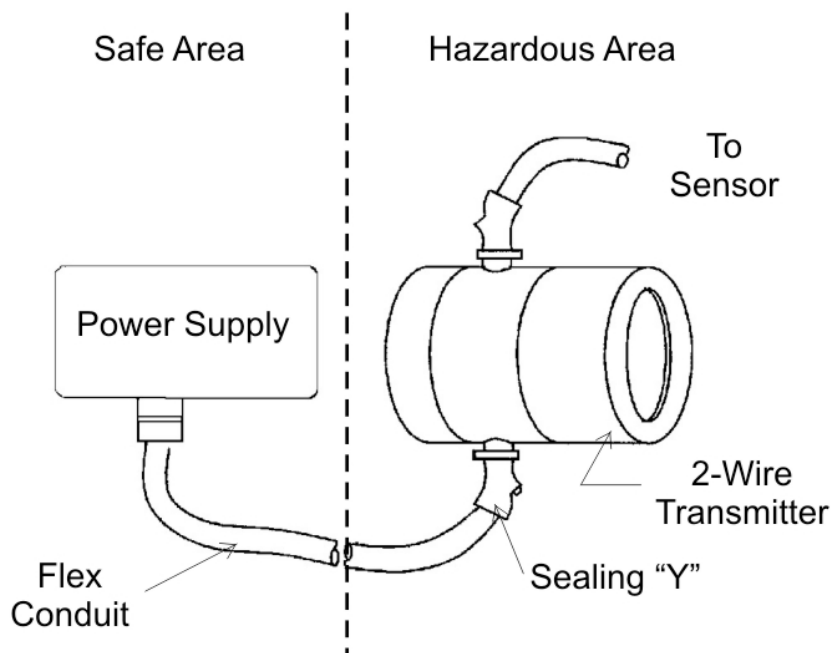

Figure 2-1: Typical Installation for the LXT-280 Transmitter

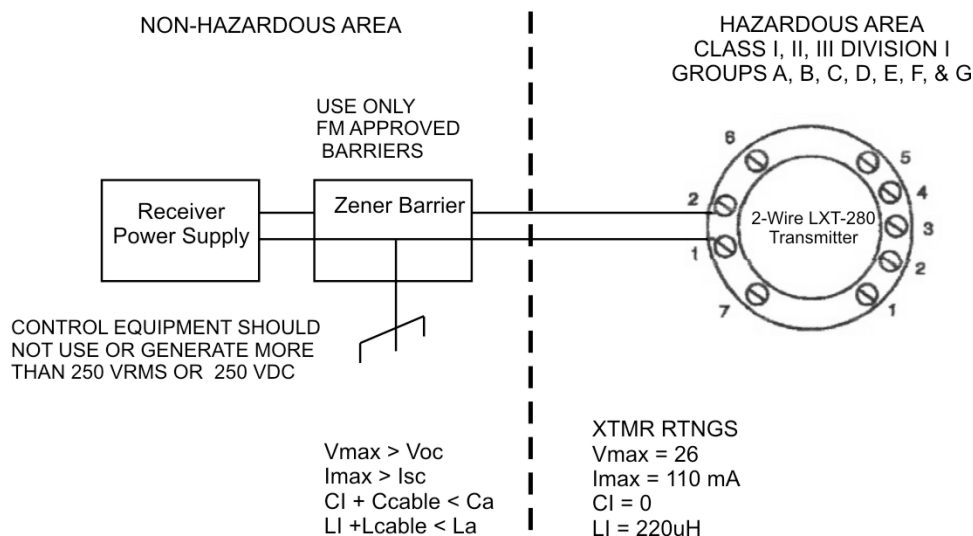

Figure 2-2: Intrinsically Safe Wiring Diagram

2.3 Wiring

2.3.1 Site Wiring

Two conduits should be run to the transmitter location, one for the sensor and the other for the 24 VDC-power source. Proper methods of terminating the conduit for hazardous locations should be reviewed by your local plant safety engineer based on State and Federal requirements.

2.3.2 Power Wiring

For power wiring, the LXT-280 transmitter requires a nominal 24-VDC voltage source. With zero loop impedance, the minimum voltage requirement is 14 VDC. The maximum voltage limit is 50 VDC. Maximum loop impedance at 24 VDC is 450 ohms for the 4-20 mA compliance. Impedance levels higher than 450 ohms will require additional DC voltage.

Figure 2-3 illustrates the proper 24 VDC power wiring for the LXT-280 transmitter. When connecting the power wires, it is important to

observe the polarity. Although no damage to the LXT-280 will result from polarity reversal, the instrument will not function.

For intrinsically safe wiring see Figure 2-2.

CAUTION: DO NOT APPLY 110 VAC TO THE 24 VDC WIRING TERMINALS. DAMAGE TO THE INSTRUMENT WILL RESULT!



2.3.3 Sensor Wiring

A conditioned input is required from the sensor or electrode to the LXT-280 transmitter for proper operation. Teledyne models SP-1 and SP-2 sensors will provide the required conditioning. Figure 2-3 illustrates the proper wiring of the sensor to the LXT-280 transmitter.

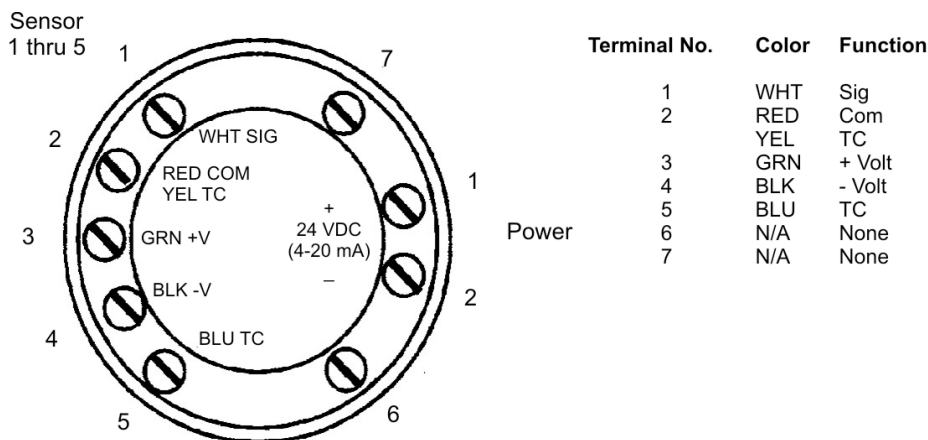

Figure 2-3: LXT-280 Wiring

2.3.4 DC Power

The LXT-280 requires an external 24 VDC power source to operate. With zero loop impedance, the minimum voltage requirement is 13.5 VDC. The maximum voltage limit is 50 VDC. Maximum loop impedance at 24 VDC is 525 ohms for the 4-20 mA compliance. Impedance levels higher than 525 ohms will require additional DC voltage.

2.4 Configuring the LXT-280

The LXT-280 Transmitter is used for measurement and control in hazardous environments for a wide range of liquid analytical applications. This manual describes the configuration for use in dissolved oxygen measurement and control applications. The unit is Factory Mutual approved as intrinsically safe for use in Class I, II, and III Divisions 1 Groups A through G hazardous areas.

Configuring the instrument is described in Section 3 of this manual.

2.5 Calibration

Prior to using the instrument for the first time, the LXT-280 must be calibrated. The specific calibration procedure used depends on the application. Among other things, the calibration routine establishes the correspondence between the 4-20 mA output signal and the application dependant measurable parameter.

Calibration can be performed without disturbing control or recorder functions using a manual output mode (see Section 4.2). Typically, the calibration is done using either a one-point buffer calibration (standardization) or two-point (span) calibration. There is also a Back to Factory calibration feature which resets the LXT-280 to “nominal electrode” situation. This reverts to an electrode with zero millivolts offset at zero percent or ppm oxygen and a full scale output of -400 mV. This is useful as a starting point if the instrument has been mis-calibrated.

The calibration routines require a familiarity with the instrument operation and is described after fundamental operational parameters are discussed in Section 3.

Operation

This section will provide an overview of the front panel key functions and the display menus for the LXT-280 Dissolved Oxygen transmitters.

3.1 Using the Front Panel Keys

The operator keys on the explosion proof model are located behind a sight glass window sealed from the environment. They are magnetic and are operated by touching the glass in front of the appropriate key using the supplied magnetic screwdriver. This allows instrument operation without having to open the cover and expose the internal parts to the environment. Figure 3-1 shows the layout of the LXT-280 faceplate.

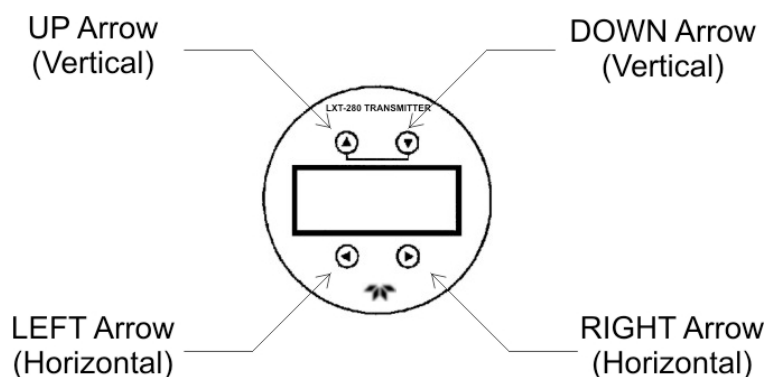

Figure 3-1: LXT-280 Operator Interface

The operator keys are arranged in two groups:

1. VERTICAL UP/DOWN (▲/▼) Arrow Keys
These keys are used to change the display menu and to move the cursor vertically. Any menu can be accessed by magnetically activating the appropriate UP or DOWN key.

These keys also perform numeric adjustments to display values while in the calibrate mode. Magnetically activating the UP ▲ vertical arrow key will increase the value; magnetically activating the DOWN ▼ vertical arrow key will decrease the value.

2. HORIZONTAL LEFT/RIGHT (◀/▶) Arrow Keys
The RIGHT and LEFT arrows are used to enter the calibrate mode. To enter the calibrate mode, magnetically activate the RIGHT ▶ horizontal arrow key. Once in the calibrate mode, the cursor can be positioned by magnetically activating the RIGHT or the LEFT horizontal arrow key. To exit the calibrate mode, magnetically activate LEFT ◀ horizontal arrow key until the cursor is all the way to the left.

These keys are also used to move the cursor horizontally.

3.2 Menus

The LXT-280 contains a series of menus from which different functions can be accessed. You can scroll through all available menus by activating the VERTICAL ▲ and ▼ keys.

The menus available in the LXT-280 instrument configured for dissolved oxygen transmitters are shown in Figure 3-2.

When the instrument is first powered up, a copyright display will appear for a few seconds. This screen displays the serial number and software version for your instrument. After a few seconds the display changes to the main menu. The Copyright Display provides the software "version" number (2.20) and the software serial number (67). Teledyne will require this information if software updates are to be performed.

S/N	18	V	2.23
(C)TI/TAI			2006

To access any of the menus listed below, magnetically activate the desired vertical arrow key with an instrument magnet.

From the main menu, you can scroll up (▲) to the Contrast menu or down (▼) through the available menus for your transmitter.

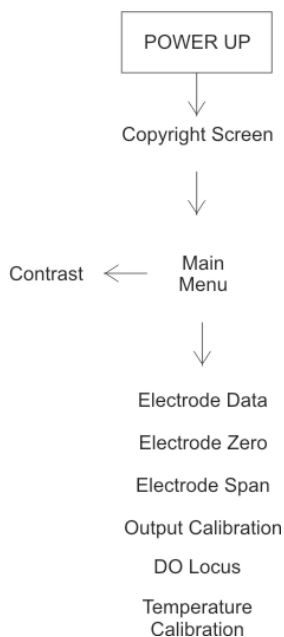
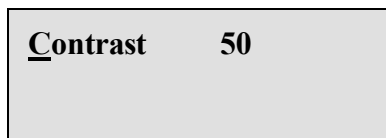

Figure 3-2: Available Menus

In this manual, gray screens apply to dissolved oxygen in percent instruments while white screens apply to dissolved oxygen in ppm instruments. When only one screen is illustrated, the screen is applicable to both instruments.

3.2.1 Contrast

Display contrast can be adjusted to allow for variations of ambient lighting and viewing angle by using this menu. The Contrast Menu is always located as the uppermost menu. To access the contrast menu from the Main Menu, magnetically activate the UP vertical arrow key once.



3.2.2 Main Menu

This menu appears after the copyright display when power is first applied to the LXT-280. The MAIN MENU displays the measured process variable, temperature, and the current output in percent of full-scale. While in this menu, the current output can be adjusted and locked in a manual mode to provide an undisturbed output during sensor calibrations.

DO	90.0 %
_50.0%	25.0°C

DO	10.0 ppm
_50.0%	25.0°C

3.2.3 Electrode Data Screen

As an informational screen only, this display provides diagnostic data pertaining to the electrode. The top line displays the real-time (active) absolute millivolt value (mVa) the electrode is generating; it is not compensated for temperature variations.

Input	480.0
0 mV	.1

Electrode Diagnostic Screen, DO %

Input	275.0
0 mV	.4

Electrode Diagnostic Screen, DO ppm

This value can be used to determine the saturation limit of the sensor and the maximum effective range of the instrument with that sensor and electrode. For example, if the maximum desired instrument range is 20 ppm, and the real-time mVa is 275 mV at an oxygen level of 10 ppm, the maximum effective range of the sensor and electrode is 18.18 ppm. This is calculated by using the equation below. Please note that the 500 mV value used in the equation is the maximum input to which the LXT-280 Dissolved Oxygen transmitter will respond.

$$\text{Effective range} = (500 \text{ mVa} / \text{Input mVa}) \times (\text{DO value @ the Input mVa})$$

In the example above, the effective range was calculated as:

$$\text{Effective Range} = (500 \text{ mVa} / 275 \text{ mVa}) \times (10 \text{ ppm})$$

$$\text{Effective range} = (1.818) \times (10 \text{ ppm})$$

$$\text{Effective range} = 18.18 \text{ ppm}$$

A reading higher than 18.18 ppm is not meaningful under the circumstances given in the above example. At 18.18 ppm, the millivolt input from the sensor is greater than 500 mV and saturates the transmitter input circuitry.

The bottom line of the Electrode Data Screen displays the electrode zero offset from the last zero calibration. This value is the dissolved oxygen value at which the electrode output is zero millivolts. Because the Electrode Data Screen indicates the deviation from zero, the information is helpful in determining the quality of the dissolved oxygen electrode. In conjunction with regular calibrations, the Electrode Data Screen can provide valuable information to track electrode service.

3.2.4 Electrode Zero Menu

This menu provides the means with which to perform the zero calibration for the Dissolved Oxygen electrode. The screen shown below shows the Electrode Zero Menu for Dissolved Oxygen in percent oxygen or ppm oxygen.

<u>2</u> DO	100.0
Cal	-400.0

ElectrodeSpsn Menu, %

2 DO	.0
Cal	-400.0

Electrode Span Menu, ppm

Before entering the calibrate mode, the menu provides historical data from the last calibration. The top line displays the buffer, or calibration point, at which the last calibration was performed. The bottom line displays the temperature compensated mV value the electrode generated at the calibration point.

Calibration procedures are described in Section 4.

3.2.5 Electrode Span Menu

From this menu, you can perform the span calibration for the dissolved oxygen electrode. Before entering the calibrate mode, the menu provides historical data from the last calibration.

The top line displays the calibration point at which the last calibration was performed. For DO transmitters, the bottom line displays the electrode slope, or efficiency, in millivolts at full scale. When in the calibrate mode, the bottom line displays the real-time, or active, millivolt value.

<u>2</u> DO	100.0
Cal	-400.0

Output Calibration Menu, %

<u>2</u> DO	.0
Cal	-400.0

Output Calibration Menu, ppm

3.2.6 Output Calibration Menu

On the next menu, the current output ranges are displayed and can be adjusted in this menu.

The 4 mA and 20 mA points may be defined in percent dissolved oxygen or parts per million dissolved oxygen, depending on the software installed in the transmitter. The maximum allowable ranges are 0 to 200% and 0 to 20 ppm.

<u>4</u> mA	.0
20 mA	200.0

Output Calibration Menu, %

4 mA	.0
20 mA	20.0

Output Calibration Menu, ppm

3.2.7 DO Locus

The DO Locus Menu defines the point at which a family of dissolved oxygen concentration curves intersect for a specific sensor or electrode. The locus is derived by plotting the sensor output versus temperature at different dissolved oxygen concentrations. Empirical data for Teledyne sensors defines the locus to be approximately -17°C. Because dissolved oxygen sensors have different temperature slopes at

different concentrations, the locus must be determined and used to normalize the temperature to 25°C. This value should not be changed unless a sensor different than the Teledyne sensor is used. Each sensor manufacturer should define the locus for their sensor.

<u>L</u> ocus	-17.0
---------------	-------

Output Calibration Menu, %

3.2.8 Temperature Calibration Menu

This screen has two calibrate functions and a conversion function. It is used to adjust or trim the temperature compensation for variations in the sensing element. It is also used to provide a manual temperature input for the process. The top line displays the temperature offset value. The bottom line displays the adjusted temperature value. You can also convert and toggle between °C and °F temperature units from this screen. See Section 4.11.3.

<u>T</u> rim °C	.0
Unit	24.3°C

Calibration

4.1 Calibration

A complete calibration of the LXT-280 Dissolved Oxygen transmitter involves:

1. Zero calibration
2. Span calibration
3. Output calibration
4. DO Locus calibration
5. Temperature calibration (trim)

In general, once the instrument has been setup, only step 2 will be required for calibration although it is recommended that the output and temperature calibration be occasional rechecked and adjusted as necessary. It is also highly recommended that you perform a zero calibration (step 1) periodically to check for drift and whenever a new sensor is installed.

It may be useful to set the contrast of the display prior to calibration to compensate for current lighting conditions.

Note: Before calibrating the LXT-280, place the instrument in Manual Mode. See the following section.

4.2 Manual Output Mode

In order to perform calibrations without interfering with control or recorder functions, the LXT-280 incorporates a manual output mode. In the manual output mode, the current output is set to the desired level and saved until changed or released from the manual mode. The following procedure demonstrates the use of the manual output.

Procedure:

1. If not at the Main Menu, magnetically activate the appropriate VERTICAL ▲/▼ arrow key.

2. With the cursor on the second line of the main menu, magnetically activate the RIGHT HORIZONTAL key ► to enter the calibrate mode and observe the "M" appearing in front of the % current output value. The "M" signifies that the manual output is locked in the manual mode.
3. Using the HORIZONTAL arrow keys, position the cursor under the digit to be adjusted.
4. Increase or decrease the value by magnetically activating the appropriate VERTICAL ▲/▼ arrow key.
5. When the desired value is reached, exit while leaving the transmitter in the manual output mode, by magnetically activating the LEFT ◀ arrow key until the cursor is under the "M". As long as the "M" is in front of the output % the current output of the transmitter will be held at that filed value.

DO	17.00 ppm
<u>M</u> 24.3%	25.0°C

To release manual output:

1. Return to the Main Menu by magnetically activating the appropriate VERTICAL ▲/▼ arrow key.
2. Observe that the "M" appears in front of the % current output value. This "M" signifies that the transmitter output is in manual mode.
3. Magnetically activate the LEFT HORIZONTAL ◀ arrow key and observe the "M" disappear, releasing the LXT-280 from the manual output mode. The % output value will return to the real-time current output.

4.3 Contrast Adjustment

Display contrast can be adjusted to allow for variations of ambient lighting and viewing angle. The Contrast Menu is the uppermost menu and is accessed with the UP VERTICAL ▲ arrow key.

Procedure:

1. With an instrument magnet, activate the UP VERTICAL ▲ arrow key to reach the Contrast Menu.
2. Magnetically activate the RIGHT HORIZONTAL ► arrow key to enter the calibrate mode. Observe the cursor move to the last digit.
3. Using the HORIZONTAL ◀▶ arrow keys, position the cursor under the digit to be adjusted. Increase or decrease the value by magnetically activating the appropriate VERTICAL ▲/▼ arrow key.
4. To save the contrast value and exit the calibrate mode, magnetically activate the LEFT HORIZONTAL ◀ arrow key until the cursor is all the way to the left.

4.4 Zero Calibration

Because dissolved oxygen sensors experience minor variations in membrane thickness, permeability, surface area and in the signal conditioning amplifier from one sensor to the next, the zero point may differ. In some cases, especially in low ppm measurements, a zero calibration may be desirable.

Two zero calibrations are possible with a dissolved oxygen sensor:

1. Simulation of a zero oxygen environment
2. Using a true zero oxygen environment

The simulation of a zero oxygen environment is the easiest and can be performed with good results; however, for extreme accuracy at the low-end (near zero), the true oxygen environment is preferred. These two calibration procedures are discussed in detail in the SP-1/SP-2 Sensor Manual. The following procedure describes the steps used to calibrate a DO sensor to the LXT-280 instrument.

Procedure:

1. With an instrument magnet, activate the appropriate VERTICAL ▲/▼ arrow key to reach the Electrode Standardization Menu and locate the cursor under the "1".
2. For diagnostic reasons note the pH and mV values from the prior calibration.
3. Clean the electrode and insert the sensor into the desired buffer.

4. Magnetically activate the RIGHT HORIZONTAL ► arrow key to enter the calibrate mode. Observe the diagnostic value on the bottom line change from historical data to a real-time value and that the term "Cal" has disappeared.

1 DO	<u>0</u> 0.2 mV
------	--------------------

5. To change the buffer point, position the cursor under the desired digit using the LEFT HORIZONTAL ◀ arrow key.
6. Increase or decrease the value by magnetically activating the appropriate VERTICAL ▲/▼ arrow key.
7. Wait for the real-time mV value to stabilize.
8. To save the calibration and exit the calibrate mode, magnetically activate the LEFT HORIZONTAL ◀ arrow key until the cursor is all the way to the left and the term "Cal" on the second line reappears.

Perform a span calibration after the zero calibration.

4.5 Span Calibration

The span calibration is typically the only calibration that needs to be performed on a routine basis. This calibration compensates for changes in the membrane or deterioration of the electrolyte. Teledyne recommends the span calibration be performed in air or in an oxygen standard that is near the range in which the process normally operates. These two span calibrations are described in the SP-1/SP-2 Sensor Installation and Maintenance Manual.

The following procedure describes the steps used to calibrate the LXT-280 to the sensor. If performing an air span calibration where the unit of measurement is ppm, review Section 5.0, Calibration Correction Factors. This instrument calibration procedure can also be used to calibrate to a sample that has been analyzed through a wet chemical process, such as a Winkler analysis.

Procedure:

1. Perform a zero calibration as outlined in Section 4.4.

2. Magnetically activate the DOWN VERTICAL ▼ arrow key to reach the Electrode Span Menu and locate the cursor under the "2".
3. For diagnostic reasons note the slope values from the prior calibration.
4. Magnetically activate the RIGHT HORIZONTAL ► arrow key to enter the calibrate mode. Observe the diagnostic value on the bottom line change from historical data to a real-time value and that the term "Cal" has disappeared.

2 DO	100.0
mv/dec	

5. To change the buffer point, position the cursor under the desired digit using the LEFT HORIZONTAL ◀ arrow key.
6. Increase or decrease the value by magnetically activating the appropriate VERTICAL ▲/▼ arrow key.
7. Wait for the real-time mV value to stabilize.
8. To file the calibration and exit the calibrate mode, magnetically activate the LEFT HORIZONTAL ◀ arrow key until the cursor is all the way to the left and the term "Cal" on the second line reappears.

A typical DO electrode will indicate a full scale value of -400 mV. See the equation in Section 3.2.3 for information on determining the effective range of the electrode.

CAUTION:  **IF A FLASHING ASTERISK APPEARS DURING OR AFTER CALIBRATION, THE ELECTRODE MAY REQUIRE SERVICE, OR THE BUFFER SOLUTION MAY BE CONTAMINATED. SEE SECTION 4.7.**

Comparing the millivolt values before and after the calibration provides a valuable diagnostic tool in determining the degradation of the electrode. Minor differences in the full scale value is normal; however,

large differences between calibrations may indicate coating or damage to the membrane.

4.6 Automatic Buffer Calibration

Once the calibration points have been defined in the LXT-280 by performing the zero and span calibration, the Automatic Buffer Calibration feature can be utilized. This feature allows calibrations to be performed without making any adjustments. The procedure is the same for the zero and span calibrations.

Procedure:

1. Go to the appropriate calibration menu and locate the cursor on the top line
2. Insert the sensor in the known solution as defined by the calibration point on the top line.
3. Magnetically activate the RIGHT HORIZONTAL ► arrow key to enter the calibrate mode.
4. Wait for the real-time mV to reach its minimum value (zero calibration) or wait for the real-time mV value to stabilize (span calibration).
5. Magnetically activate the LEFT HORIZONTAL ◀ arrow key until the cursor is all the way to the left and the term “Cal” appears on the second line. This will store the calibration data.

4.7 Calibration Error Detection

If the calibration performed in section 4.5 is not within the predetermined limits of the instrument, a flashing asterisk (*) will appear behind the full scale millivolt value.

The presence of the asterisk indicates a potential calibration problem and can be ignored if there are special considerations allowing this condition to be valid. In general, if the asterisk appears, the integrity of the electrode, the calibration procedure or the handling procedure should be questioned.

4.8 Back-to-Factory Calibration

This feature allows the LXT-280 to be reset to "nominal electrode" situation. This condition is an electrode with zero millivolts offset at zero percent or ppm oxygen, and a full scale output of -400 mV. This factory calibration feature is very useful in providing a reliable starting point if the instrument has been mis-calibrated.

CAUTION: IDEAL INSTRUMENTATION CALIBRATION DOES NOT IMPLY IDEAL SYSTEM CALIBRATION.



Before using the factory calibration feature, it must be understood that it provides a nominal instrument calibration and does not allow for electrode variations or shortened span of the electrode in service. In order to obtain ideal system calibration, a span calibration is required.

The following procedure for returning the LXT-280 back-to-factory calibration can be used for both zero and span calibrations.

This procedure is required at BOTH of the calibration points.

Procedure at the Zero Menu:

6. Magnetically activate the appropriate VERTICAL ▲/▼ arrow key to reach the Electrode Zero Menu.
7. Position the cursor under the "C" in "Cal."
8. Magnetically activate the RIGHT HORIZONTAL ► arrow key and observe the cursor briefly move to the right and the mV value change to 0.00. The default setting is complete.
9. Verify the calibration by observing a .0 calibration point at .0 mV.

2 DO	.0
<u>Cal</u>	-400.0 mV

Procedure at the Span Menu:

1. Magnetically activate the appropriate VERTICAL ▲/▼ arrow key to reach the Electrode Span Menu.
2. Position the cursor under the "C" in "Cal."

3. Magnetically activate the RIGHT HORIZONTAL ► arrow key and observe the cursor briefly move to the right and the full scale millivolt value changes to -400.0. The default setting is complete.
4. Verify the calibration by observing a .0 calibration point at -400 mV/FS.

2 DO	.0
Cal	-400.0

4.9 Output Calibration

The Output Calibration screen is used to define the 4-20 mA range for the measurement. The values in the menu are in the units being measured. Maximum ranges are 0-200 % and 0-20 ppm.

To change or expand the 4-20 mA range, use the following procedure.

Procedure:

1. Magnetically activate the appropriate VERTICAL ▲/▼ arrow key to reach the Output Calibration Menu.
2. Position the cursor on the top line to change the 4 mA point or the bottom line to change the 20 mA point.
3. Magnetically activate the RIGHT HORIZONTAL ► arrow key to enter the calibrate mode.
4. To change the value, position the cursor under the desired digit using the left LEFT HORIZONTAL ◀ arrow key.
5. Increase or decrease the value by magnetically activating the appropriate VERTICAL ▲/▼ arrow key.
6. When the desired value is reached, save the calibration and exit the calibrate mode by magnetically activating the LEFT HORIZONTAL ◀ arrow key until the cursor is all the way to the left.

4.10 Locus Calibration

As stated in section 3.2.7, the locus value for Teledyne SP-1 and SP-2 sensors is approximately -17.0°C and should not be changed unless a different manufacturer's sensor is used. If the locus is not -17°C , use the following procedure to define the correct locus.

Locus -17°C

Procedure:

1. Magnetically activate the appropriate VERTICAL ▲/▼ arrow key to reach the Locus Menu.
2. Magnetically activate RIGHT HORIZONTAL ► arrow key to enter the calibrate mode. Observe the cursor move to the last digit on the right.
3. Using the HORIZONTAL ◀▶ arrow keys, position the cursor under the digit to be adjusted.
4. Increase or decrease the value by Magnetically activating the appropriate VERTICAL ▲/▼ arrow key.
5. To file the locus value and exit the calibrate mode, Magnetically activate the LEFT HORIZONTAL ◀ arrow key until the cursor is all the way to the left.

4.11 Temperature Calibration

The Temperature Calibration screen is used to:

1. Adjust the temperature to coincide with measuring device
2. Toggle temperature units between $^{\circ}\text{C}$ and $^{\circ}\text{F}$

4.11.1 Temperature Adjustment

When the process demands a tighter tolerance than $\pm 3^{\circ}\text{C}$ of the temperature input, the LXT-280 allows adjustment, or trim, for variations in the temperature compensation element. This adjustment only compensates for deviations in the RTD input (as a sensor input

standardize or zero adjustment). It is independent of the zero and span adjustments for the temperature output on LXT-280 models with the temperature output option.

Note: The tolerance of standard Teledyne TC elements is $\pm 3^{\circ}\text{C}$. If greater precision is desired, contact the factory.

Procedure for trim adjust:

1. Begin with the temperature sensing element (located in the sensor) immersed in a solution of known temperature. If the temperature is not known, insert a precision thermometer in the same solution and allow time for it to stabilize.
2. Magnetically activate the appropriate VERTICAL ▲/▼ arrow key to reach the Temperature Calibration Menu.
3. Position the cursor on the top line under the “T” in Trim.
4. Magnetically activate the RIGHT HORIZONTAL ► arrow key to enter the calibrate mode. Observe the cursor move under the last digit.
5. Position the cursor under the desired digit using the left HORIZONTAL ◀ arrow key.
6. Increase or decrease this value to make the value on the bottom line read the same as the temperature indicated by the precision thermometer.

Note: Make temperature adjustments slowly to allow time for the bottom line on the display to update. This can take 5 to 7 seconds.

7. When the desired temperature value is reached, save the calibration and exit the calibrate mode by magnetically activating the LEFT HORIZONTAL ◀ arrow key until the cursor is all the way to the left. The value on the top line expresses the temperature error. The value on the bottom line expresses the real-time process temperature.

4.11.2 Temperature Calibration—Manual TC Adjustment

The manual TC feature allows the LXT-280 to operate without a temperature sensor only if the process temperature is known and

constant. This adjustment also applies should the TC element in the sensor fail to either an open or shorted condition.

Procedure to adjust manual TC:

1. Place a 3,000 ohm, 1% resistor across terminals TB1-2 and TB1-5 in place of the sensor wires on the LXT-280 transmitter.
2. Magnetically activate the appropriate VERTICAL ▲/▼ arrow key to reach the Temperature Calibration Menu.
3. Position the cursor on the top line.
4. Magnetically activate the RIGHT HORIZONTAL ► arrow key to enter the calibrate mode. Observe the cursor move under the last digit.
5. Position the cursor under the desired digit using the LEFT HORIZONTAL ◀ arrow key.
6. Increase or decrease this value with the VERTICAL ▲/▼ arrow keys to make the value on the bottom line read the process temperature.

Note: Make temperature adjustments slowly to allow time for the bottom line on the display to update. This can take 5 to 7 seconds.

4.11.3 Temperature Units Calibration – °C/°F Conversion

The Temperature Calibration screen is also used to change the units of display to either Celsius or Fahrenheit. The displayed temperature is converted as the units are toggled from one unit to the other. Changes in the displayed units are automatically made on all screens or menus where temperature is displayed. The following procedure describes how to use this feature.

Procedure:

1. Magnetically activate the appropriate VERTICAL ▲/▼ arrow key to reach the Temperature Calibration Menu.
2. Position the cursor on the bottom line under the “U” in Unit.
3. Magnetically activate the RIGHT HORIZONTAL ► arrow key. Observe the unit of measurement change.
4. To toggle back to the first unit of measurement, magnetically activate the RIGHT HORIZONTAL ► arrow key again.

Trim°	.0
<u>Unit</u>	25.0 °C

Trim°	.0
<u>Unit</u>	77.0 °F

Calibration Correction Factors

5.1 Calibration Correction Factors

Temperature, relative humidity, elevation and salinity factors affect the solubility of oxygen in a liquid and thus affect the accuracy of the dissolved oxygen calibration using the air calibration method. The affect on solubility is caused by barometric pressure changes due to changes in the atmospheric environment. Because the dissolved oxygen sensor responds to pressure changes, the output of the sensor will be affected by these pressure variations. To correct for these factors, refer to the tables below.

Please note that the tables only apply to absolute dissolved oxygen measurements (those in ppm or mg/l and not to relative dissolved oxygen measurements (typically expressed as percent oxygen). The data is used when performing an **air span calibration** or an **air saturated sample calibration**.

To compensate for these effects, use the following procedure:

1. Determine the temperature of the air (if the electrode is being calibrated in air only) or the temperature of the air saturated sample (if the electrode is being calibrated in solution).
2. Refer to Table 5-1, Oxygen Saturation vs. Temperature and find the solubility value of oxygen in ppm for that temperature. Interpolation may be necessary if the temperature is between the listed values. Record this value.

Table 5-1: Oxygen Saturation vs. Temperature

Oxygen Saturation in ppm (mg/l) at an Overall Pressure of a Water Vapor Saturated Atmosphere at 29.9” Hg (760 mm Hg)

Temp. °C	Solubility in ppm	Temp. °C	Solubility in ppm
0	14.62	22	8.83
2	13.84	24	8.53
4	13.13	25	8.37
6	12.48	26	8.22
8	11.87	28	7.92
10	11.33	30	7.63
12	10.83	32	7.40
14	10.37	34	7.20
16	9.95	36	7.00
18	9.54	38	6.80
20	9.17	40	6.60

3. Determine the relative humidity if performing the calibration in air only. If calibrating in an air saturated sample, assume a relative humidity of 100%.
4. Referring to Table 5-2, Relative Humidity Correction Factors, find the intersection of the relative humidity and the temperature axis. Use the temperature closest to the values listed. Interpolation is not necessary. Record the correction value.
5. Determine the elevation from sea level.
6. Referring to Table 5-3, Elevation Correction Factors, find the intersection of the nearest thousand feet and hundred feet to the elevation at which the calibration is being performed. Record the correction value.

Table 5-2: Relative Humidity Correction Factors

Relative Humidity	Temperature in °C							
	0	5	10	15	20	25	30	35
0%	1.000	1.000	1.000	1.000	1.000	1.000	1.000	1.000
10%	.999	.999	.999	.998	.998	.997	.996	.994
20%	.999	.998	.998	.997	.995	.994	.992	.989
30%	.998	.997	.996	.995	.993	.991	.987	.983
40%	.998	.997	.995	.993	.991	.987	.983	.978
50%	.997	.996	.994	.992	.988	.984	.979	.972
60%	.996	.995	.993	.990	.986	.981	.975	.967
70%	.996	.994	.992	.988	.984	.978	.971	.961
80%	.995	.993	.990	.987	.982	.975	.967	.956
90%	.995	.992	.989	.985	.979	.972	.962	.950
100%	.994	.991	.988	.983	.977	.969	.958	.945

Table 5-3: Elevation Correction Factor

Feet	Elevation Correction Factor							
	0	1,000	2,000	3,000	4,000	5,000	6,000	7,000
0	1.000	.964	.930	.897	.865	.834	.804	.775
100	.996	.961	.926	.893	.861	.831	.801	.772
200	.993	.957	.923	.890	.858	.828	.798	.770
300	.989	.954	.920	.887	.855	.825	.795	.767
400	.986	.950	.916	.884	.852	.822	.792	.764
500	.982	.947	.913	.880	.849	.819	.788	.761
600	.978	.943	.910	.877	.846	.816	.787	.758
700	.975	.940	.906	.874	.843	.813	.784	.756
800	.971	.937	.903	.871	.840	.810	.781	.753
900	.968	.933	.900	.868	.837	.807	.778	.750

7. To calculate the compensated dissolved oxygen value, multiply the ppm oxygen value (recorded from Table 5-1) by the two correction factors (recorded from Tables 5-2 and 5-3). This value is the dissolved oxygen value of air or an air-saturated sample corrected for temperature, relative humidity and elevation.
8. After the corrected value has been calculated, but before the value has been entered in the instrument, the temperature element in the sensor must have time to stabilize. The temperature of the sensor must be the same as the temperature used in selecting the ppm value in Table 5-1. If the temperature of the sensor and value used from Table 5-1 are not the same, an error will be introduced into the calibration.

5.2 Salinity Correction

When seawater, brine or brackish samples or processes are being measured, a special salinity correction table is required. The correction factor is multiplied by the corrected dissolved oxygen value as determined in Section 5.1. Table 5-4 summarizes the salinity correction factors at a barometric pressure of 29.92" Hg (760 mm Hg).

Table 5-4: Salinity Correction Factor

Dissolved Oxygen Salinity Correction Factors at a Barometric Pressure of 29.92" Hg (760 mm Hg)			
Salinity in ppt	Correction Factor	Salinity in ppt	Correction Factor
0	1.00	20	0.81
2	0.98	22	0.80
4	0.96	24	0.78
6	0.94	26	0.76
8	0.92	28	0.75
10	0.90	30	0.73
12	0.88	35	0.70
14	0.86	40	0.66
16	0.85	45	0.63
18	0.83	50	0.60



5.3 Calibration Example

As an example of a ppm calibration, assume a dissolved oxygen application where the sample temperature is 30°C at an elevation of 1,500 feet. The calibration is being performed in the sample which is a brine having a salinity value of 6 ppt.

1. Determine the oxygen saturation in ppm at 30°C from Table 5-1. This value is 7.63 ppm.
2. Determine the relative humidity correction factor (CF_{RH}) from Table 5-2. Because the calibration is being performed in the sample, a relative humidity of 100% is assumed. At a relative humidity of 100% and a temperature of 30°C, the relative humidity correction factor is 0.958.
3. Determine the elevation correction factor (CF_E) from Table 5-3. At 1,500 feet, the elevation correction factor is 0.947.
4. Determine the salinity correction factor (CF_S) from Table 5-4. At 6 ppt, the salinity correction factor is 0.94.
5. Calculate the corrected ppm value as follows:

$$\text{Corrected ppm} = \text{oxygen saturation} \times CF_{RH} \times CF_E \times CF_S$$

Using the data from the tables,

$$\text{Corrected ppm} = 7.63 \text{ ppm} \times 0.958 \times 0.947 \times 0.94$$

$$\text{Corrected ppm} = 6.51$$

5.4 Grab Sample Calibration

In some cases, calibration to a grab sample is desired. If so, the sensor can be compared to a sample that has been analyzed through a wet chemical process (Winkler analysis) or by using a laboratory electrode. After determining the dissolved oxygen concentration by one of these methods, the SP-1 or SP-2 can be standardized to that value.

5.5 Dissolved Oxygen Units of Measurement

One popular dissolved oxygen unit of measurement is an absolute value and is expressed as milligrams per liter (mg/l) or parts per million (ppm). Milligrams per liter and parts per million are two ways of expressing the same measurement (i.e. $1 \text{ mg/l} = 0.000001$ part of oxygen per weight). These units of measurement are typically found in applications where saturated oxygen must be controlled for a chemical reaction or where the presence of saturated oxygen is detrimental to the process.

Another unit of measurement is a relative value and is expressed as percent oxygen saturation or percent solubility. With percent oxygen, the instrument is calibrated to 100% in air or an oxygen rich environment. Subsequent measurements are an indication of oxygen consumption. This unit of measurement is typically used in environments that must be oxygen-rich, such as bioreactors, fermenters and waste-water aeration basins.

Maintenance

6.1 Routine Maintenance

Aside from normal cleaning routine maintenance is limited to recalibration. For recalibration, see Section 4 *Calibration*. However, if service of the internal components is required always turn off the power to the instrument.

6.1.1 Cleaning

Before cleaning, the integrity of the enclosure seals should be inspected. Also check the conduit fittings and seals to make sure moisture does not enter the enclosure while cleaning.

If the enclosure cover must be removed, it is wise to clean and inspect the o-ring seal. If the seal is damaged, replace the o-ring. Always keep the gasket lightly lubricated with a silicone grease.

6.1.2 Replacement of the Microprocessor:

For replacement of the microprocessor, contact the factory .

CAUTION: NEVER INTERCHANGE EPROMS FROM ONE TRANSMITTER TO ANOTHER. DOING SO WILL AFFECT TRANSMITTER PERFORMANCE.



Table 6-1: Troubleshooting

SYMPTOM	POSSIBLE CAUSES	SUGGESTED ACTION
The LCD does not display.	No power to the instrument.	Check power supply to be sure the correct voltage is being supplied to the transmitter. Check polarity of transmitter wiring.
	Contrast level is set too low.	Set contrast level to a higher value. Because the contrast menu is always the top menu, it can be reached by pressing the upper MENU SELECTION key at least 12 times. Enter the calibrate mode and increase the value.
	Sensor or signal conditioner has a short that draws too much power from the transmitter.	Check the sensor for proper operation. To verify, disconnect all sensor wires and cycle power off, then on.
Erratic dissolved oxygen readings or the sensor is not responsive to oxygen changes	Sensor not wired properly	Using the proper wiring diagram, verify that the sensor is properly wired to the transmitter.
	Sensor and the electrode are not properly submerged in the process	Verify that the sensor housing and the electrode are in contact with the process.
	Electrode cartridge is not fully engaged in the sensor body	Check electrode cartridge to see that it is fully engaged in sensor body
	Air bubble is trapped in front of the electrode.	Remove the electrode from the sensor body and shake air bubble away from the membrane. Check the sensor position with respect to horizontal. Make sure air is not trapped in the guard.

	Broken membrane	Replace the electrode cartridge.
	Process flow is not adequate across the electrode membrane	Locate the sensor within an adequate flow or create agitation within the process.
	Sensor is located too close to the oxygen injection point.	Locate the sensor further from the oxygen injection point.
	Signal conditioner not properly engaged in the rear of the sensor body.	Verify that the signal generator is properly engaged in the rear of the sensor body.
	Instrument has been improperly calibrated. May have been calibrated with no slope (infinite gain)	Verify instrument calibration electronically, then recalibrate per Section 4.
Slow Response	Membrane is coated	Clean the membrane. See Sensor manual.
	Protective Boot was left on the front of the sensor.	Carefully remove the protective boot.
No Span	Broken membrane	Replace electrode cartridge.
	Temperature compensator (TC) is open.	Verify that the sensor is properly connected including the TC connections. Check for a damaged TC in the sensor body. Replace if damaged.
Reading drifts upscale or zero calibration reads upscale	Broken membrane	Replace the electrode cartridge.
Short span or the electrode does not respond to a second calibration point.	Broken membrane	Replace the electrode cartridge.
	Coated membrane	Clean the membrane. See Sensor manual. Verify instrument calibration.
	Electrode cartridge is not fully engaged in the sensor body	Check electrode cartridge to see that it is fully engaged in sensor body

	Sensor not wired properly	Using the proper wiring diagram, verify that the sensor is properly wired to the transmitter.
Sensor output is off-scale	Sensor is not wired properly.	Verify that the sensor is wired properly to the transmitter using the applicable wiring diagram.
	Sensor and the electrode are not properly submersed in the process.	Verify that the sensor body and the electrode are submersed in the process.
	Electrode cartridge is not fully engaged in the sensor body	Check cartridge to see that it is fully engaged in the sensor body.
	TC Module in sensor is not functioning properly	Observe temperature reading on display. If it shows a major discrepancy to the actual temperature, measure across TC wires on sensor — it should be 3000 ohms at 25°C.
	Signal conditioner not properly engaged in the rear of the sensor body.	Verify that the signal generator is properly engaged in the rear of the sensor body.
	Temperature trim not properly adjusted	Verify temperature display and temperature trim adjustment.
	Transmitter or analyzer failure	Verify that the sensor is not the cause of the problem. Troubleshoot the instrument and correct the problem
The DO reading is over-sensitive or under-sensitive with temperature changes.	The locus point is not correct	Verify the correct locus. If using Teledyne sensors, the locus must be -17°C.

A troubleshooting procedural recommendation:

In troubleshooting an analytical measurement loop, it should be kept in mind that the majority of the problems encountered with the measurement are due to failures of the sensing element. Therefore, it is recommended that the troubleshooting procedure start with the sensing end of the measurement and work backwards to the instrument.

Appendix

A.1 Specifications

Packaging: FM approved SS NEMA-7C explosion-proof enclosure suitable for use in Class I, Div. I, Groups C through G.
Electronics: FM approved for use in Class I, Div. I, Groups A through G

Power Requirements: 24 VDC, Maximum 50 VDC, Minimum 13.5 VDC

Output: 4-20 mA or 20-4 mA, linear and expandable. Maximum 3 outputs.

Max. Loop Impedance: 525 ohms for 4-20 mA compliance.

Power Supply— Relay Module (Optional):

115/230 VAC, 50/60 Hz, 0.5 A
2 ea. Form C, SPDT dry contacts, 5.0 A.

Display: Menu driven 32 alphanumeric character display, Supertwist LCD. Simultaneously displays process ID, Process value and units, % output and temp in °C or °F.

Sensor: Application specific

Ranges: 0-200 % fully expandable and reversible.
0-20 ppm.

Response Time: 90% of step change in 1 second

Accuracy: ±0.10% of full scale

Linearity: ±0.05% of full scale

Sensitivity: ±0.01 ppm
±0.1 percent saturation

Stability: ±0.2% per year @ 0 to 70°C

Input/Output Isolation: Max 300V between process input and 4-20mA output (single and multiple channel outputs). No isolation between inputs on multiple channel units.

Operating Temperature: -4 to 158°F (-20 to 70°C)

Temp. Compensation: Automatic, -30 to 140°C, RTD. Accuracy within $\pm 0.1\%$ over a 0-100°C span.

Dimensions: 8.7 cm x 12.5 cm

Calibration: Auto Buffer Calibration

Allows definition of two buffer points, saved in memory, during the initial startup. This allows subsequent zero and span calibrations with only 2 keystrokes.

Back-to-Factory Calibration

With 2 keystrokes, allows user to return to a zero electrode offset and to the typical full scale millivolt offset.

Temperature Trim

Allows for compensation for any differences in RTDs by programming the offset to the transmitter.

Temperature Display

Temperature can be field-configured to display in °C or °F.

A.2 Spare Parts Listing

Qty	P/N	Description
1	ECD-2000261	Universal Mounting Bracket Assembly (not including U-bolt)
1	ECD-2000300	O-ring kit, Viton, for LXT-280 Enclosure (2 O-rings & lubricant)
1	ECD-2000394	Front Cover, Housing, LXT-280, Stainless Steel
1	ECD-3300071	Rear Cover Housing, LXT-280, Stainless Steel
1	ECD-2000403.3001	Electronic Module, including PROM calibrated for DO %
1	ECD-2000403.3013	Electronic Module, including PROM calibrated for DO ppm
1	ECD-2000404	LXT-280 Enclosure, complete, without Universal Mounting Bracket
1	ECD-9680066	“U” bolt 2” x 3 1/2”, 304 SS (includes nuts and washers)
1	ECD-9680069	Terminal Screw and Clamp Assembly, set of 9
1	ECD-9680044.1	Instrument Screwdriver with Magnetic Top

Note: In order to provide replacement proms for the LXT-280, the transmitter serial number and the software serial number are needed. The transmitter serial number is located on the serial number tag located inside the instrument. The software serial number can be found by briefly turning off the power to the instrument, then applying the power again. The serial number is a four-digit number located on the Copyright Display.

A minimum charge is applicable to spare parts orders.

Note: Orders for replacement parts should include the part number (if available) and the model and serial number of

the instrument for which the parts are intended.

Orders should be sent to:

TELEDYNE Analytical Instruments

16830 Chestnut Street

City of Industry, CA 91749-1580

Phone (626) 934-1500, Fax (626) 961-2538

Web: www.teledyne-ai.com
or your local representative.

Index

- absolute dissolved oxygen, 31
- absolute millivolt value, 14
- accuracy, 31, 41
- active millivolt value, 16
- address, 44
- arrow keys, 2
- automatic buffer calibration, 24
- automatic calibration, 2
- back to factory calibration, 2, 9, 25, 42
- barometric pressure, 31
- buffer point, 15
- calibrate mode, 4, 12
- calibration, 9, 19, 42
- calibration correction factor, 31
- calibration error, 24
- calibration example, 35
- caution sign, iv
- change menu, 11
- combustible gas warning, x
- compensated dissolved oxygen, 34
- conditioned input, 8
- conductivity, 1
- conduit, 7
- contrast, 13
- contrast adjustment, 2, 20
- contrast menu, 13, 20
- copyright, ii
- copyright display, 12
- current output, 14. *See* output
- cursor, 3
- cursor positioning, 4, 11
- dc power, 8
- default parameters, 2
- dimensions, 42
- display, 2, 3, 41
- display contrast. *See* contrast
- dissolved oxygen, 1
- dissolved oxygen unit, 36
- DO locus menu, 16
- effective range, 14, 15
- electrode, 8, 14
- electrode data screen, 14
- electrode degradation, 23
- electrode output, 14
- electrode potential, 9
- electrode slope, 16
- electrode span screen, 16
- electronics, 1
- elevation correction factor, 33
- enter calibrate mode, 12
- enter manual mode, 20
- exit calibrate mode, 12
- exit manual mode, 20
- explosion proof, 1
- faceplate, 11
- Factory Mutual, x, 1, 9
- feature codes, 4
- features, 2
- flashing asterisk, 24
- front panel, 11
- full scale value, 23
- gasket, 37
- grab sample, 35
- hazardous area classifications, 1, 9
- historical calibration data, 15
- horizontal arrow keys, 4, 12
- ideal electrode, 9
- impedance, 7, 8, 41
- input, 8
- installation, 5
- instrument configuration, 4
- intrinsic safety barrier, 1, 6
- intrinsically safe, 1, 6
- isolation, 42
- key, 3, 11
- linearity, 41
- locus, 16
- locus calibration, 19, 27
- locus value, 27
- M display, 20
- magnet, 2
- magnetic screwdriver, 11
- magnetic switch, 1, 2, 11
- main menu, 14
- manual mode, 9, 14, 19
- manual temperature compensation, 28

- manuals, additional, v
- membrane, 22
- menus, 12
- microprocessor replacement, 37
- mis-calibration, 9
- model designation, 4
- NEMA, 1, 41
- nominal electrode, 25
- numeric adjustment, 3, 12
- one-point calibration, 9
- operating temperature, 42
- optional software, 2
- options, 2
- o-ring, 37
- ORP, 1, 2
- output, 1, 2, 9, 41
 - adjustment, 14
 - current setting, 19
 - range, 16
- output calibration, 19
- output calibration menu, 16
- output calibration screen, 26
- oxidation-reduction potential. *See* ORP
- oxygen consumption, 36
- oxygen saturation, 32
- parts per million
 - ppm, 1
- percent of full-scale, 14
- percent oxygen, 1, 15
- percent oxygen saturation, 36
- percent solubility, 36
- pH, 1
- pipe mount, 5
- polarity, 8
- power, 1, 8, 41
- power supply, 1, 5
- power wiring, 7
- ppm, 1, 15
- pressure, 31
- process control, 1
- process variable, 14
- range, 2, 16, 26, 41
- range adjustment, 16
- real-time millivolt value. *See* active millivolt value
- relative dissolved oxygen, 31
- relative humidity, 32
- relative humidity correction factor, 33
- relay module, 41
- release manual mode, 20
- resistivity, 1
- response time, 41
- reverse acting, 2
- routine maintenance, 37
- RTD, 27
- safety barrier. *See* intrinsic safety barrier
- safety information, iv
- salinity correction factor, 34
- saturation, 15
- saturation limit, 14
- security access, 2
- sensitivity, 41
- sensor, 1, 8
- sensor output, 31
- serial number, iii
- silicone grease, 37
- site wiring, 7
- slope. *See* electrode slope
- solubility, 31
- SP-1, SP-2 sensors, 8
- span, 16, 19
- span calibration, 9, 22
- span fluid recommendation, 22
- spare parts, 43
- specifications, 41
- stability, 41
- standardization, 9
- sunshade, 6
- tables listing, ix
- technician symbol, iv
- Teledyne address, 44
- temperature, 14
- temperature calibration, 19
- temperature calibration screen, 27, 29
- temperature compensation, 17, 42
- temperature conversion, 2
- trim, 42
- trim adjustment, 27
- troubleshooting, 38
- true zero, 21
- two-point calibration, 9, 16
- unit conversion, 17
- units conversion, 29
- unpacking, 5
- vertical arrow keys, 3, 11
- viewing angle, 13
- voltage
 - maximum, 7, 8
 - minimum, 7, 8

- wall mount, 5
- warning sign, iv
- warranty, ii
- weather-proof enclosure, 41
- web address, 44
- website address, v
- window, 2, 11
- Winkler analysis, 22
- zero calibration, 15, 19, 21
- zero electrode offset, 2
- zero offset, 15
- zero simulation, 21