

**OPERATING INSTRUCTIONS FOR**

**IR7000**

**NDIR Gas Analyzer**

REV. 3

**Copyright © 2000 Teledyne Analytical Instruments.**

All Rights Reserved. No part of this manual may be reproduced, transmitted, transcribed, stored in a retrieval system, or translated into any other language or computer language in whole or in part, in any form or by any means, whether it be electronic, mechanical, magnetic, optical, manual, or otherwise, without the prior written consent of Teledyne Analytical Instruments, 16830 Chestnut St. City of Industry, Ca. 91748

**Warranty**

This equipment is sold subject to the mutual agreement that it is warranted by us to be free from defects of material and of construction, and that our liability shall be limited to replacing or repairing at our factory (without charge, except for transportation), or at customer plant at our option, any material or construction in which defects become apparent within one year from the date of shipment, except in cases where quotations or acknowledgments provide for a shorter period. Components manufactured by others bear the warranty of their manufacturer. This warranty does not cover defects caused by wear, accident, misuse, neglect or repairs other than those performed by Liston or an authorized service center. We assume no liability for direct or indirect damages of any kind and the purchaser by the acceptance of the equipment will assume all liability for any damage which may result from its use or misuse.

We reserve the right to employ any suitable material in the manufacture of our apparatus, and to make any alterations in the dimensions, shape or weight of any parts, in so far as such alterations do not adversely affect our warranty.

**Important Notice**

This instrument provides measurement readings to its user, and serves as a tool by which valuable data can be gathered. The information provided by the instrument may assist the user in eliminating potential hazards caused by his process; however, it is essential that all personnel involved in the use of the instrument or its interface be properly trained in the process itself, as well as all instrumentation related to it.

The safety of personnel is ultimately the responsibility of those who control process conditions. While this instrument may be able to provide early warning of imminent danger, it has no control over process conditions, and it can be misused. In particular, any alarm or control systems installed must be tested and understood, both as to how they operate and as to how they can be defeated. Any safeguards required such as locks, labels, or redundancy, must be provided by the user or specifically requested of Teledyne Analytical Instruments at the time the order is placed.

Therefore, the purchaser must be aware of the hazardous process conditions. The purchaser is responsible for the training of personnel, for providing hazard warning methods and instrumentation per the appropriate standards, and for ensuring that hazard warning devices and instrumentation are maintained and operated properly.

Teledyne Analytical Instruments cannot accept responsibility for conditions beyond its knowledge and control. No statement expressed or implied by this document or any information disseminated by the manufacturer or its agents, is to be construed as a warranty of adequate safety control under the user's process conditions.

## **Table of Contents**

<b>Important Safety Information</b> .....	<b>S-1</b>
<b>S.1 General Format</b> .....	<b>S-1</b>
<b>S.2 Specific Hazards</b> .....	<b>S-2</b>
<b>Introduction</b> .....	<b>1</b>
<b>1.0 Overview</b> .....	<b>2</b>
<b>1.1 Standard Features</b> .....	<b>4</b>
<b>1.2 Optional Features</b> .....	<b>4</b>
<b>1.3 IR Detection</b> .....	<b>6</b>
<b>1.4 Operator Interface</b> .....	<b>6</b>
<b>Operational Theory</b> .....	<b>8</b>
<b>2.1 Introduction</b> .....	<b>8</b>
<b>2.2 Optical Bench</b> .....	<b>8</b>
<b>2.3 Electronics</b> .....	<b>11</b>
<b>2.3.1 Power Supply Board</b> .....	<b>11</b>
<b>2.3.3 Main Board</b> .....	<b>12</b>
<b>2.3.4 Display Board</b> .....	<b>14</b>
<b>2.3.5 I/O Board</b> .....	<b>14</b>
<b>2.4 Sample System</b> .....	<b>14</b>
<b>2.5 Internal Gas Handling System</b> .....	<b>16</b>
<b>Installation</b> .....	<b>18</b>
<b>3.1 Overview</b> .....	<b>18</b>
<b>3.2 Unpacking and Installation</b> .....	<b>18</b>
<b>3.3 Mounting the Analyzer</b> .....	<b>18</b>
<b>3.4 Gas Connections</b> .....	<b>19</b>
<b>3.5 Sample System Considerations</b> .....	<b>20</b>
<b>3.6 Electrical Connections</b> .....	<b>21</b>
<b>3.6.1 Analog Output</b> .....	<b>22</b>
<b>3.6.2 Analog Output Connections</b> .....	<b>25</b>
<b>3.6.3 Solenoid Valve Connections</b> .....	<b>25</b>
<b>3.6.4 Optional Relay Outputs</b> .....	<b>26</b>
<b>3.6.5 Digital I/O Option</b> .....	<b>27</b>
<b>3.6.6 RS-232 Cable</b> .....	<b>28</b>
<b>3.6.7 Power Connections</b> .....	<b>29</b>



<b>Operation.....</b>	<b>31</b>
4.1 Overview .....	31
4.2 The SETUP Menu.....	31
4.3 The MODE Menu.....	39
<b>Calibration .....</b>	<b>46</b>
5.1 Overview .....	46
5.2 Typical Sample System .....	46
5.3 Manual Calibration .....	47
5.3.1 Manual Zero Calibration.....	47
5.3.2 Manual Span Calibration.....	48
5.4 AUTO Calibration .....	50
5.5 Calibration Issues .....	51
<b>Maintenance .....</b>	<b>53</b>
6.1 Scheduled Maintenance .....	53
6.1.1 Cleaning .....	53
6.1.2 Particle Filter .....	53
6.2 Service .....	55
6.2.1 Removing the Optical Bench.....	55
6.2.2 Cleaning the Sample Cell.....	58
6.2.3 Replacing the IR Source .....	59
6.2.4 Replacing the Battery (Portable Model Only) ...	59
6.2.5 Changing the Fuse .....	60
6.3 Display Messages .....	61
6.3.1 Error Messages.....	62
6.3.2 Normal Operation Messages .....	65
6.3.3 Normal Operator Induced Messages .....	66
<b>Appendix .....</b>	<b>69</b>
A-1 Specifications.....	69
A-2 Recommended Spare Parts List .....	71
A-3 RS-232 Communication Protocol .....	72
A-3.1 Codes for "e" Type Messages .....	76
A-3.2 Codes for "s" Type Messages .....	77
A-3.3 Codes for "c" Type Messages .....	77
A-3.4 Codes for "m" Type Messages.....	78
A-3.5 Codes for "a" Type Messages.....	78
<b>Addendum A.....</b>	<b>.....</b>
<b>Configuration and Compliance Certificates</b>	
<b>Addendum B.....</b>	<b>.....</b>
<b>Automatic Calibration Electrical Connection Diagram</b>	

## Important Safety Information

---

### S.1 General Format

Important information relating to health and safety of personnel, possible equipment damage and special instructions regarding instrument setup and operation are setoff and highlighted within this manual. The following format will be used in this manual to indicate safety hazards and special instructions:

Symbol	Heading	Typeface and Description
	<b>WARNING</b>	<b>12 point bold typeface. Contains important information which if ignored could result in personal injury or death.</b>
	<b>CAUTION</b>	<b>12 point bold typeface. Contains important information which if ignored could result in damage to the system.</b>
No Symbol	<b>NOTE</b>	<i>12 point Italic typeface. Contains important or helpful information relating to the setup and/or operation of the system.</i>

**Read this instruction manual carefully and familiarize yourself thoroughly with its contents. Do not ignore any warnings or cautions or operate this equipment with any safety feature**

defeated or inoperable. Failure to heed warnings or cautions can result in injury or death as well as damage to the instrument.

## S.2 Specific Hazards

**WARNING:** **ELECTRICAL HAZARD!** Hazardous voltage is present inside. Keep away from Live Circuits. Under no circumstances should untrained personnel open any panel or remove any cover, lid or wiring harness without proper guidance and supervision.



Component replacement, internal adjustments and electrical service must be made by qualified maintenance personnel. Always disconnect the power cable and discharge circuits before servicing the equipment. To avoid accidental power up, Liston recommends using an electrical lock-out device whenever maintenance is to be performed. Disconnect power to any other equipment connected to the instrument to avoid the possibility of component failure and transmission of dangerous voltage through signal connections.

**WARNING:** **FLAMMABLE GAS HAZARD! EXPLOSION HAZARD! TOXIC GAS HAZARD!** Do not operate this instrument in an explosive atmosphere. Read all documentation that comes with this instrument especially any application notes or addenda which, among other important details, may specify the nature and properties of the gas to be analyzed.



Unless specifically designed for hazardous environment application, this instrument is not designed to handle explosive or flammable gases. Exposed electrical terminals pose a substantial risk of ignition if powered in the presence of flammable gas. The sample system is not appropriate for handling toxic, flammable or explosive gases!

If your application requires using toxic, flammable or explosive gases for analysis or calibration, please consult the factory. An explosion proof instrument with enhanced sample system is available as an option.

**WARNING:** **ELECTRICAL HAZARD!** This instrument must be properly grounded.



To avoid shock hazard, the instrument chassis and cabinet must be connected to an electrical ground. The instrument is equipped with a three conductor AC power cable. This cable must be plugged into an approved three-contact electrical outlet. The power jack and plug of the power cable meet International Electro-Technical Commission (IEC) safety standards. When replacing this cable, use only the proper replacement cable as listed in the Spare Parts Listing in the Appendix.

**WARNING: Do not attempt to service or make adjustments to this equipment while working alone.**



Whenever servicing or adjusting this equipment, notify your supervisor and have another person capable of rendering first aid standby in case of an accident.

**WARNING: Do not substitute parts or modify this instrument.**





The IR7000 was designed and tested at the factory. The quality, safety and workmanship inherent in this product is a result of careful design, selection and assembly of components. Any use of non-authorized replacement parts can impair the functioning of this system. In addition to voiding your warranty, any substitution of non-authorized replacement parts or unauthorized modifications to the instrument can create an unnecessary risk of harm. Return the analyzer to Teledyne Analytical Instruments for service and repair to ensure proper functioning of the unit.

**WARNING: Do not operate a damaged instrument.**



If any of the built-in safety features of this instrument is impaired, either through physical damage, excessive moisture, or any other reason, **IMMEDIATELY REMOVE POWER**. Do not use the instrument until safe operation can be verified by service-trained personnel. If necessary, return the instrument to Teledyne Analytical Instruments. for service and repair.

	<b>DANGER</b>	
<p>HIGHLY TOXIC AND/OR FLAMMABLE LIQUIDS MAY BE PRESENT IN THIS MONITORING SYSTEM</p> <p>PERSONAL PROTECTIVE EQUIPMENT MAY BE REQUIRED WHEN SERVICING THIS SYSTEM.</p> <p>HAZARDOUS VOLTAGES EXIST ON CERTAIN COMPONENTS INTERNALLY WHICH MAY PERSIST FOR A TIME EVEN AFTER THE POWER IS TURNED OFF AND DISCONNECTED.</p> <p>ONLY AUTHORIZED PERSONNEL SHOULD CONDUCT MAINTENANCE AND/OR SERVICING. BEFORE CONDUCTING ANY MAINTENANCE OR SERVICING CONSULT WITH AN AUTHORIZED SUPERVISOR OR MANAGER.</p>		

**THIS PAGE INTENTIONALLY LEFT BLANK.**

## **Introduction**

---



## 1.0 Overview

The Teledyne analytical Instruments Model IR7000 Non-Dispersive Infrared Gas Analyzer is a versatile microprocessor based analyzer for measuring or monitoring a gas stream. The IR7000 analyzer is available in a variety of configurations to suit most applications.

The IR7000 series analyzer is designed for rapid monitoring of a process gas stream. Four user definable chart ranges are available for accurate monitoring over the full range of the process gas composition. A trace analysis unit is available for analysis at low ppm levels. This manual describes the setup and operation of the Model IR7000. It also covers particular features of the other analyzers in the IR7000 series where setup and operation differs from the standard unit.

MODEL	DESCRIPTION
IR7000	Panel/19" Rack Mount – CE Mark
IR7010	Split Architecture, Analysis Unit – Explosion Proof
IR7000P	Portable Battery Operated with AC Charger
IR7000T	Similar to IR7000 for Trace Analysis

IR7000D	Dual Optical Bench for Monitoring 2 Gases
IR7000B	Wall Mount Unit

The standard rack mount model IR7000 is shown in Figure 1-1 and the portable IR7000P is shown in Figure 1-2. The explosion proof models have the analysis unit installed in an explosion proof housing and employ steel tubing and fittings in the sample system. The control unit on these models is separate from the analyzer and generally located outside the hazardous environment.

## 1.1 Standard Features

The following features are standard on the IR7000 series of analyzers:

- User selected automatic zero and span calibration
- Linearized output over the entire full scale range eliminating the need for separate instrument ranges to achieve full span
- Closed sample path is not exposed to ambient air eliminating the need for purging of the cell compartment
- Four user-definable chart ranges plus auto-ranging
- Selectable analog output: 0–1, 0–5, or 0–10V or optionally, a 4–20mA non-isolated or isolated current output
- High and low alarms or limits with adjustable setpoints. The alarms are configured at the factory for either latching or non-latching operation
- Modular design for easy maintenance
- Configured to easily accommodate an optional oxygen channel for simultaneous oxygen analysis at either 0–25% or 0–100%
- Patented IR detector uses a sensitive mass flow sensor and a dual chamber for rapid analysis of IR absorption in a sample flow
- Unique optical bench design eliminates mechanical chopping of IR source
- IR bench does not require tuning for maximum signal like other optical NDIR systems
- Self-diagnostic software installed
- Easy setup and maintenance
- Easy to operate with all user controls accessible from the front panel
- CE Mark (IR7000 Rack and battery portable)

## 1.2 Optional Features

To extend the versatility of the Ir7000 series of analyzers, many options are available.

- Dual optical bench for simultaneous monitoring of 2 gases
- Oxygen channel (0–25% or 0–100%). The IR7000 series easily accepts Teledyne analytical Instruments oxygen electrochemical cell for measuring oxygen levels in the process gas.
- RS-232 port for control input and data output via a remote computer
- 4–20ma analog current output either isolated or non-isolated

- Relay outputs. Single pole double throw (SPDT) relays driven off the status signal, high, and low limit alarms can be installed for triggering status alarms, indicators, or other customer supplied peripherals.
- External sample system. The instrument can be supplied with a sample handling system ensuring safe delivery of conditioned sample gas to the analyzer.
- Z-Purge system. The split-architecture models can be fitted with a Z-Purge system for automatic purging of the NEMA-4 enclosure.

### 1.3 IR Detection

Central to the IR7000 analyzer is the unique patented IR detector. It incorporates 2 chambers in optical series at the end of a gold-coated sample cell. The chambers are connected through a tiny orifice. IR is differentially absorbed in the 2-chambered detector and causes a mass flow between the chambers. The modulation of the IR signal causes the chambers to quickly readjust and the flow reverses. A sensitive mass flow sensor located in the tiny orifice between the 2 chambers senses the flow in both directions and outputs a signal related to the concentration. A high-resolution electronic circuit is employed to provide synchronous detection of the flow sensor's signal. This circuit allows the IR7000 to measure gas compositions over a wider range of the infrared spectrum than conventional photon-based IR analyzers.

### 1.4 Operator Interface

Except for the split architecture models (Explosion Proof), the analysis and control sections are housed together in a single compact metal housing. A NEMA-4 enclosure is used on the IR7000B wall mountable model.

All operator input and display of process information takes place from the panel (or on the control section panel for the split architecture instruments). There are minor differences in the location of some of the components among the different models within the IR7000 series but each instrument has the following front panel components:

- **Display**—vacuum fluorescent with 2 lines of 16 characters. The display sends data and information to the user about the process and guides the operator through the calibration and operation.

- **Input Buttons**—4 push buttons are installed on the front panel and are used to enter data and set operational modes.
- **Flowmeter**—an integral flowmeter is mounted on the front panel for monitoring the sample flow through the instrument.
- **Power Switch**—an off/on switch is mounted on the front panel for powering up the instrument.
- **Sample Pump Switch** (IR7000P only)—this switch controls the operation of the sample pump on portable models.
- **Sample Pump Connector** (IR7000P only)—a quick disconnect nylon fitting is mounted on the front panel of portable models for attaching the sample probe to the instrument.

## Operational Theory

---

### 2.1 Introduction

The IR7000 is a microprocessor controlled, single beam infrared analyzer that employs an electronically modulated IR source with no moving parts.

The analyzer is composed of 2 subsystems:

- Optical Bench
- Electronics

### 2.2 Optical Bench

At the heart of the IR7000 NDIR Gas Analyzer is the patented dual chambered balanced detector. The advanced detector design offers higher sensitivity and selectivity with a greater dynamic range compared to other IR detectors in the marketplace.

The optical bench is shown in Figure 2-1. It consists of:

- Sample cell
- Detector
- IR source
- Filter cell
- Windows and seals

The sample cell is a gold coated glass tube (metal Tube Optional) through which the sample gas flows. At one end of the sample cell, infrared energy is generated by a modulated IR source. The modulation is achieved electronically by feeding the IR source a 4 Hz square wave generated by the source control circuit on the main PC board. The electronic modulation is very stable and eliminates the need for mechanical choppers and motors routinely used in other IR systems. At the other end of the optical bench is the detector and filter cell.

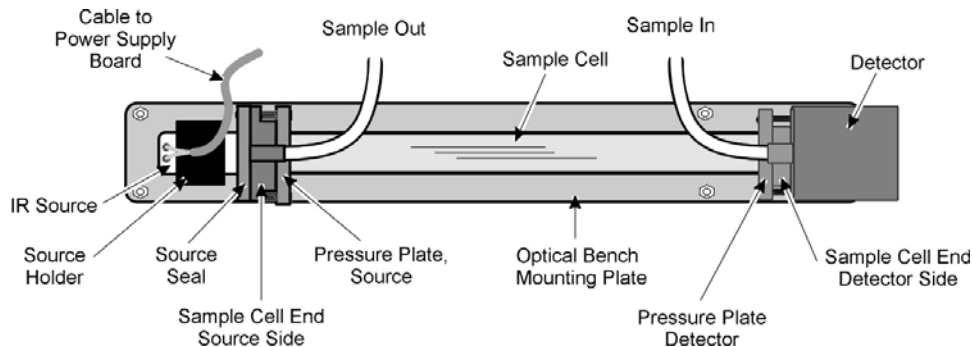

Figure 2-1: Optical Bench Components

The detector consists of 2 chambers filled with the gas of interest in optical series with a sensitive mass flow sensor. The sensor measures a fluctuating mass flow between the 2 chambers due to a differential in infrared absorption between the chambers.

The 2 chambers of the detector are of unequal volume, the first chamber, called the primary chamber, is much smaller than the trailing chamber, or secondary chamber. A small passageway connects the 2 chambers and contains the mass flow sensor. During assembly at the factory, both chambers are filled with the gas of interest and due to the unequal volume, a vastly different optical path length exists between the chambers.

Initially, with only nitrogen (zero gas) passing through the sample cell, pulsed IR radiation from the source passes through the cell. Since this is the zero gas, no differential absorption takes place. At the rear of the sample cell an IR transparent window (typically sapphire but may be some other material depending on the application) allows the radiation to pass into the primary detector chamber. Due to the heteroatomic nature of the gas contained within the chambers (identical to the gas to be monitored), IR absorption takes place at a few characteristic wavelengths corresponding to the most strongly absorbed lines for that particular gas in the IR spectrum. The remaining radiation passes through to the secondary chamber.

The secondary chamber has a much greater path length and therefore additional absorption takes place but at different energies. Due to the longer residence time of the optical beam in this chamber, absorption occurs at weaker absorption bands in the IR and accounts for the less intense absorption relative to the primary chamber. The remaining unabsorbed energy is eventually dissipated.

Essentially, the front chamber absorbs IR differentially at specific wavelengths characteristic of the gas of interest within the detector

chamber while the rear chamber absorbs radiation at primarily weaker absorption bands. The absorption causes the gas to heat up and the differential nature of the absorption process causes the front chamber to heat up more than the rear chamber. Since the chambers are charged with gas, the pressure in the primary chamber becomes higher than in the secondary chamber. This pressure differential causes a net flow of gas from the primary chamber to the secondary chamber through a tiny orifice connecting the 2 chambers. The gas cools in quick order and the flow reverses until the pressures are once again equal.

A mass flow sensor is placed in the orifice between the 2 chambers and senses the mass transport between them. It is designed in such a manner as to be able to sense minute flows in either direction. The sensor produces a signal resulting from an electronic imbalance each time mass flow is detected (in either direction) through the orifice. The signal is passed along to a preamplifier and then to a voltage to frequency converter for enhanced signal processing. The microcontroller retains this information as a zero gas reading for calibration and offset in real measurements.

When the process is repeated and a span gas is introduced into the sample cell, a slightly different condition exists. Now IR absorption takes place within the sample cell. Less energy is received at the detector. But since the primary chamber is smaller than the secondary chamber and differential absorption takes place at predominately strongly absorbing wavelengths within the primary chamber, the difference in energy of the gas in the primary chamber is less than when there is no IR absorption in the sample cell. The energy of the gas in the secondary chamber is also less but the change is not as dramatic. Hence the patented balanced design detector produces a different signal when an IR absorbing gas is introduced in the sample cell. The resulting signal is inversely related to the concentration of the gas of interest in the sample cell.

Between the IR window and the detector is the filter cell. Depending on the nature of the sample gas, some applications could experience interference in the absorption band spectra. For instance, both CO and CO<sub>2</sub> absorb at wavelengths in the IR very close to each other. The presence of CO<sub>2</sub> could produce a measurement error in a system designed to detect CO. The filter cell is a sealed volume of gas specifically designed to “comb out” the offending absorption line or lines before the radiation reaches the detector. The filter cell in some cases acts as a thermal barrier to keep the detector from experiencing sudden temperature fluctuations.

## 2.3 Electronics

The IR7000 uses a sophisticated microprocessor to control the signal processing, I/O, and display functions within the analyzer. Custom EPROMs are installed with permanently stored data and routines specific to the customer's application. Depending on what options are installed, 2 or more PCB's are used in the electronic subsystem. Figure 2-2 shows the location of the boards in the portable model. Other models are similar but mount the boards differently.

### 2.3.1 Power Supply

This unit is externally powered by either 120 or 230 VAC. Fuses are located on the back panel for circuit protection.

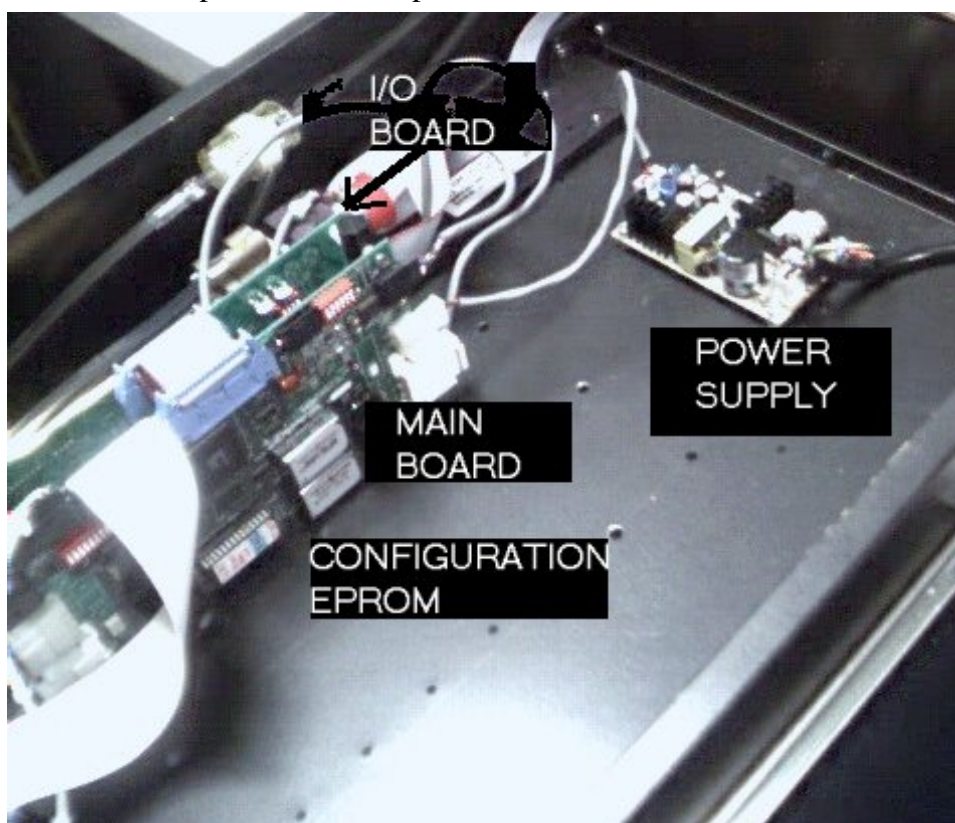

*Figure 2-2: PC Board Identification and Location*

### 2.3.3 Main Board

In effect, the main board imports an analog signal from the preamplifier and outputs a digital signal. A lot of signal conditioning and processing is performed along the way. Major functions of this board include:

- Amplification  
The signal from the detector is amplified
- Filter  
The analog signal is filtered and conditioned
- A to D Converter  
The analog signal is digitized using a voltage to frequency converter
- Microprocessor  
Encodes both the amplitude and phase of the digital signal  
Counts, integrates, and stores the signal  
Handles input and output to and from the main board
- Linearizer  
Scales and linearizes the signal using data and algorithms permanently stored in the microprocessor
- Filter  
De-spikes, pre-filters and filters the signal again with a filter rate chosen by the operator

The main board receives the raw signal from the detector and amplifies it. In the analog circuit portion of the main board, the signal is filtered to remove any electrical interference before passing it along to the digital section as a relatively clean sine wave of several volts.

The sine wave is digitized using an onboard voltage to frequency converter. In this process, both the amplitude and phase of the digital signal are encoded and integrated. The microprocessor counts the digital pulses and linearizes it using a 7th order polynomial whose coefficients were determined at the factory based on the particular detector.

The data is linearized over the entire instrument range. This linearization is inherently more accurate than the conventional process of segmenting and optimizing the data over a narrow range.

Before being sent to the read out display or output as a voltage, the result is de-spiked and filtered then scaled for the appropriate chart output range. Filtering uses a selectable algorithm to damp sudden value changes. The amount of filtering applied is determined by the operator and generally depends on the process. Large filter values yield a correspondingly lower instrument response but higher sensitivity.

The de-spiking filter is a software routine used to clean up the signal. Essentially it looks at the last 5 instrument readings and discards a reading if it varies significantly over the average. A “rolling average” method of filtering is also applied through the software. This filtering process depends on the filter value set by the user. Increasing the filter number gives more weight to the last entry into the instrument reading buffer, hence the “rolling average” is influenced to a greater degree by the last input.

Figure 2-3 is a system block diagram which shows the functional relationship between the electronics and the optical bench.

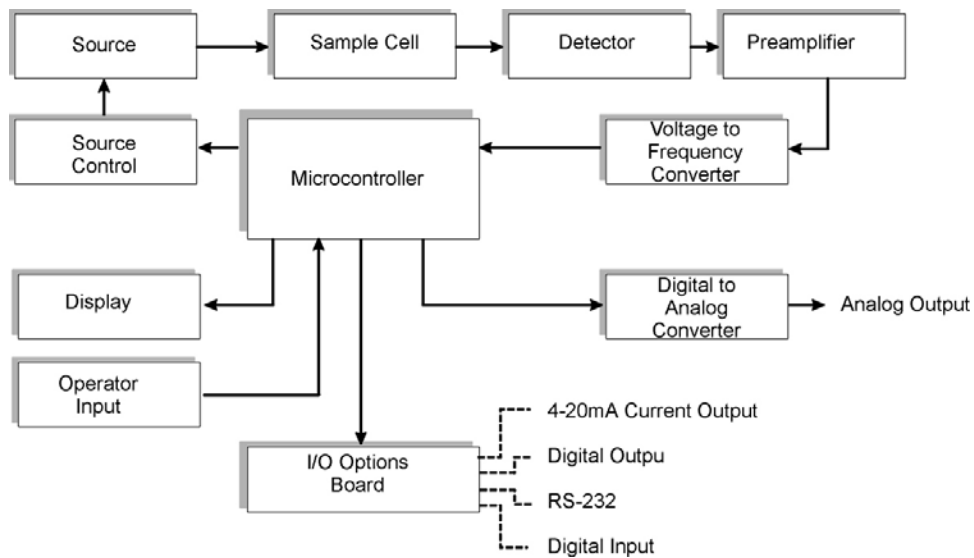

*Figure 2-3: System Block Diagram*

During calibration, the microcontroller on the main board stores information regarding zero and full span values. Specifically, the microprocessor takes a series of consecutive readings and calculates the difference between pairs of consecutive readings. The embedded software analyzes the resulting differences and tests for discrepancies in the result. The microprocessor uses this information to test for drift during calibration.

The absolute difference between a true zero and 100% span gas is determined at the factory and permanently stored in memory. The software compares this value with collected data during a calibration or measurement to determine the validity of the reading. If the calibration or sample gas measurement falls outside a predetermined range based on the known good values in memory, error routines are called and signals are sent to the display board to generate appropriate messages. See Section 5 *Calibration* for more information.

### **2.3.4 Display**

The display contains the 2-line 16 character vacuum fluorescent display on the front panel. Signals are transferred to and from the main board via a ribbon cable.

### **2.3.5 I/O Board**

The standard I/O board is responsible for taking an analog signal from the main board and converting it to a 0–1, 0–5 or 0–10 V analog output. An optional 4–20 mA isolated current output may be installed depending on the options selected by the customer. See Section 3.7.1.

## **2.4 Sample System**

If a sample system is not provided by LSC, the customer will be responsible for providing a suitable sample system. A custom sample system can be designed and fabricated by LSC based on the particular application. Contact Teledyne Analytical Instruments for details.

In order to achieve maximum results from the analyzer, some consideration must be given to the sample system design. The sample system is responsible for supplying properly conditioned sample and calibration gases to the analyzer at a pressure and flow rate commensurate with the analyzer. The sample system provided by the customer must be capable of delivering clean and moisture free (non-condensing) sample to

the instrument with a flow rate between 0.2–2.0 liters per minute (2.0 to 5.0 liters per minute for low level optical bench) **at 5 psig or less**. For samples greater than 5 psig contact factory. The sample temperature must be in the range of -10 to 50°C (14–122)°F.

**WARNING:** The maximum rated pressure of the sample cell is 5 psig. Exceeding this pressure at any time may cause the sample cell to fail. This could result in harmful release of sample gas.



The following are items to be provided by the customer:

- Calibration gases
  - Nitrogen (N<sub>2</sub>) for zero calibration
  - Span calibration gas

Use a span gas with a concentration of the gas of interest greater than 50% of the largest desired measurement. The span gas should be between 10% and 100% of the instrument's full scale, preferably around 80%. For example, if the largest expected reading is 3000 ppm, then the calibration gas should be at least 1500 ppm.

The balance of the span gas should be N<sub>2</sub>.

If the instrument has a dual optical bench (Model IR7000B or IR7000D), the span gas must contain calibration values for both species being measured.

If an optional oxygen (O<sub>2</sub>) sensor is installed, the span gas must contain a calibration value for O<sub>2</sub>. If the 0–25% O<sub>2</sub> sensor is installed, use a calibration gas containing 20% O<sub>2</sub>.

- Pressure regulator, flow adjustment valves, tubing and fittings for delivering properly conditioned sample gas to the instrument. **The sample gas pressure must be less than 5 psig**. For pressures above 5 psig contact factory.
- Pressure regulator, flow adjustment valves, tubing and fittings for delivering calibration (zero and span) gas to the instrument.
- If the automatic calibration feature is to be used, the customer must also supply 2 solenoid valves. The split architecture versions of this instrument are capable of handling 3 solenoid valves. Refer to Section 3 *Installation and Setup* for details regarding the installation of these components.
- The sample gas should be vented to atmospheric pressure. If the

sample gas is to be returned to the process or flare, suitable back pressure controls should be employed to ensure the analyzer vents at a constant pressure.

## 2.5 Internal Gas Handling System

The gas handling system inside the analyzer is similar in principle for all models. The following information describes the internal gas handling system for the IR7000 model. Variations for other models will be noted.

Figure 2-4 is a diagram of the internal components and plumbing for directing calibration or sample gas through the analyzer.

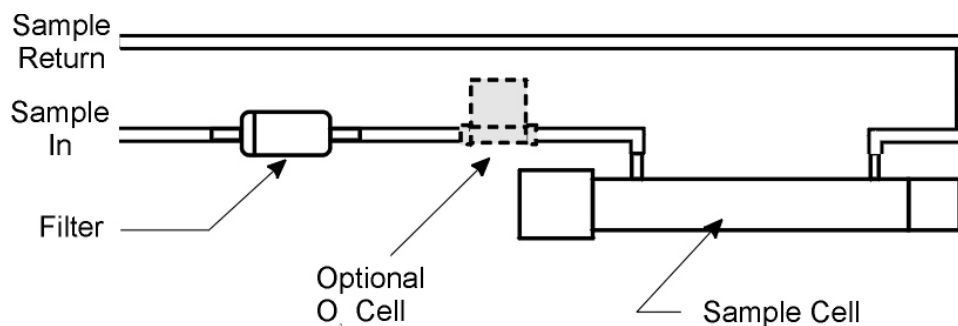

Figure 2-4: Sample Path Through Analyzer – Standard Model

Either sample or calibration gas is delivered under pressure to the analyzer by the customer or LSC supplied sample system. The gas enters the analyzer and passes through a 0.3-micron disposable filter to remove any particulate matter. If an O<sub>2</sub> channel has been incorporated, the O<sub>2</sub> sensor is installed in series with the sample cell. The gas passes first through the O<sub>2</sub> sensor and then through the sample cell and out to the sample return.

In the portable model, a 12V DC mini-pump is installed between the disposable filter and the sample cell. Otherwise the internal plumbing is the same.

The internal gas handling systems installed in the split-architecture and explosion proof models vary according to the specific application. In general, the plumbing is the same as the standard models with the following exceptions:

- Metal tubing and fittings replace Teflon lined PVC tubing

- Stainless steel, brass or copper fittings are installed for mating to the customer's sample system or throughout the system for a LSC supplied sample system.
- A different filter and a filter housing is used

*NOTE: Because these models are often supplied for custom applications, please check the front of this manual for any included Addendum which will describe features, notes and warnings that specifically apply to your instrument.*

# Installation

---

## 3.1 Overview

Installing the Model ir7000 consists of:

- Unpacking and Inspection
- Mounting
- Gas Connections
- Electrical Connections
- Calibrating the System

## 3.2 Unpacking and Installation

The analyzer is shipped ready for installation. You should have received a single carton containing the analyzer and power cord (except 230 VAC versions). If you have ordered an instrument with the optional O<sub>2</sub> sensor channel, the electrochemical cell will have been installed at the factory.

Carefully unpack the instrument and inspect it for any damage or missing components. Signs of damage would include dents, scratches, broken glass inside the casing etc. Check that you have received the power cord or battery charger for the portable model. Contact the shipper immediately to report shipping damage. Contact the factory for missing parts.

## 3.3 Mounting the Analyzer

The ir7000 series of analyzers are designed to be used indoors and in a general-purpose area. The split-architecture models (explosion proof) are designed to have the analysis unit operate in a hazardous environment with the control unit remotely located in a general-purpose area.

The instrument must be kept dry and protected from:

- Direct sunlight
- Direct air currents which could affect the temperature of the sensors

- Shock and vibration
- Temperatures below -10° C (14°F) or above 50°C (122°F)

For maximum response, locate the instrument as close to the sample line as possible.

The ir7000 is designed for mounting into a standard 19" instrument rack. When mounting, make sure that there are no fans which exhaust directly at the instrument. The IR7000B is a wall mountable unit housed in a NEMA-4 enclosure. Both this instrument and the explosion proof model should be anchored to a wall or special panel.

### 3.4 Gas Connections

The instrument requires:

- N<sub>2</sub> for zero gas
- A suitable span gas
- Sample gas

Gas connections for sample in and sample return are made on the rear panel. Barbed connectors are installed on the rear panel for connection to the customer's sample system. The IR7000P portable model has a connector on the front panel for accepting a probe for sampling. It has a barbed connector on the rear panel for the sample return.

In some installations where the sample take off is located some distance from the analyzer, it may be useful to install a bypass loop with a needle valve and flow meter just before the inlet to the analyzer. This loop can be used to shunt a portion of the sample back to the source to decrease the lag time of the system by increasing the total flow through the sample system. Whatever sample system is employed, use a regulator to limit the pressure to below 5 psig before entering the analyzer.

Once the gas connections are made, run zero gas through the analyzer to set the flow and check for leaks. Use a flow rate commensurate with your application. A higher flow will increase the instrument response but care must be taken to avoid pressurization over 5 psig. For leak testing, a commercially available soap solution is adequate for gross leak checking.

*NOTE: To run gas through the sample cell on instruments using the autocalibration feature, you must apply power to the instrument and to energize the solenoid valves.*

**WARNING:** If your application uses a toxic, flammable or explosive gas, use additional leak checking methods such as a hand held gas sniffer. Periodically, use a portable combustible gas analyzer or sniffer around all joints and fittings.



When there are no leaks in the sample system run span gas through and then sample gas to check the flow rates. If you are using a bypass loop, **do not set the sample or calibration regulators above 5 psig in an effort to increase the flow.**

### 3.5 Sample System Considerations

If a sample system is not included with the analyzer, it is the customer's responsibility for making available a preconditioned (non-condensing and particle-free) sample gas at 5 psig or less. The temperature of the gas must be between -10° C (14°F) and 50°C (122°F), preferably at the same—or close to—the temperature of the instrument.

Calibration gases (zero and span) must be tied into the sample delivery system in such a manner that the operator, or instrument, if using the automatic calibration feature, can easily switch from sample to calibration gas. Standard or custom sample systems can be provided by LSC. Contact the factory for additional information.

The sample system must be capable of maintaining a constant pressure. If a pump is used to pull sample/calibration gas through the system rather than delivering the sample under pressure, then care must be taken not to induce pressure variations during the measurements or calibrations.

**WARNING:** Do not allow the sample or calibration gas pressure to rise above 5 psig. The sample cell is glass(metal optional) and uses special elastomer O-rings for sealing. At pressures above 5 psig, the cell can fail or leak. This could result in exposure to harmful gas. Additional warnings in the form of cautions are presented in this manual whenever a gas connection is to be made. While cautions are generally used to describe potential damage to the instrument or process, the user should keep in mind the potential danger of a gas leak and it's effect on personnel.



**NOTE:** *To run gas through the sample cell on instruments using the autocalibration feature, you must apply power to the instrument and to energize the solenoid valves.*

**WARNING:** If your application uses a toxic, flammable or explosive gas, use additional leak checking methods such as a hand held gas sniffer. Periodically, use a portable combustible gas analyzer or sniffer around all joints and fittings.



- When there are no leaks in the sample system, run span gas through and then sample gas to check the flow rates. If you are using a bypass loop, **do not set the sample or calibration regulators above 5 psig in an effort to increase the flow.**

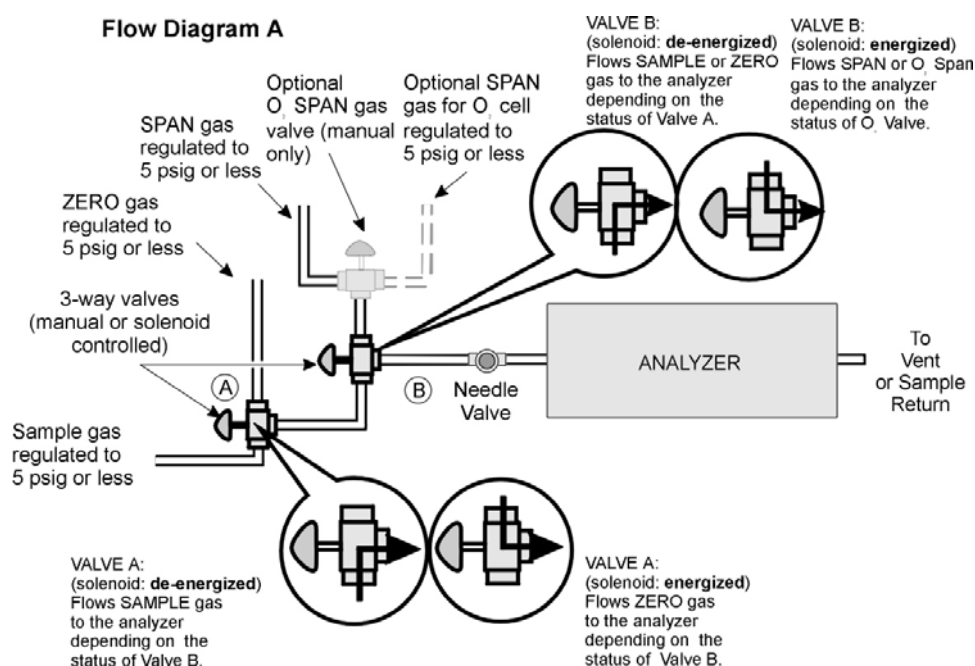

## 3.6 Electrical Connections

All electrical connections to the analyzer are made on the rear panel. Figure 3-5 shows the rear panel for the IR7000 analyzer. Other models are similar. Electrical connections to be made at the rear panel are:

- Analog output
- O<sub>2</sub> channel output (optional)
- 2 solenoid valves (3 for explosion proof model)
- 4–20 mA current output (optional)

Figure 3-1: Suggested Sample System 1 (with Optional O<sub>2</sub> Cell )

- Relay outputs (optional)
- Digital I/O (optional)
- RS-232 Communications port
- AC power connections

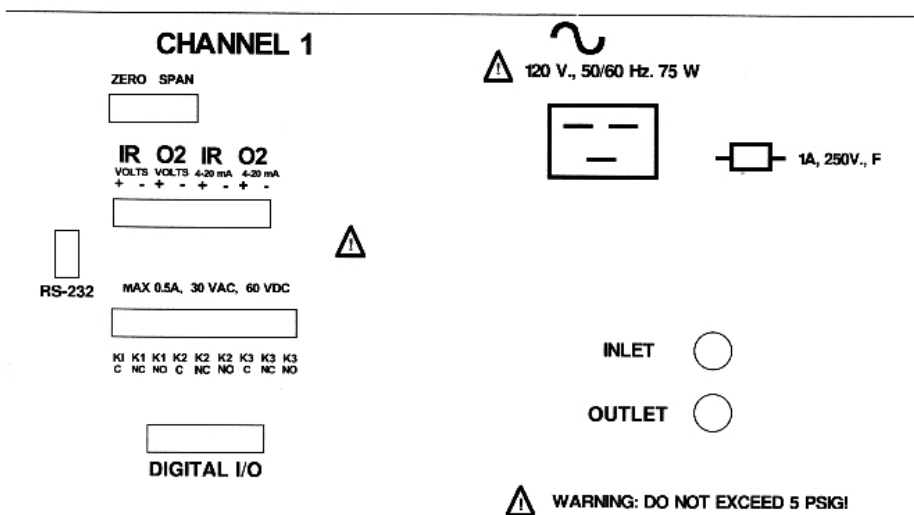

Figure 3-5: IR7000 Rear Panel

### 3.6.1 Analog Output

The standard model IR7000 is equipped with a single set of analog output terminals accessible from the rear panel. The output is set at the factory to 0–1 VDC but can be changed to 0–5V or 0–10V full scale by moving the slides on the switch labeled “S1” on the I/O board. The switch is located at the upper edge of the I/O board as shown in Figure 3-6. Use the table in the figure to set the slides for the desired output voltage. A 4–20 mA isolated or non-isolated output is also available as an option.

A second set of 0–1, 0-5, or 0-10 VDC output terminals may be driven if the optional O<sub>2</sub> monitoring channel is installed. If the instrument is equipped with a dual bench, there will be 2 sets of terminals, one for each bench.

The standard output of the analyzer is a 0–1 V DC signal and represents the concentration from 0 to full scale on the currently selected range. The output is linear over each range as long as LINEAR is set in the MODE menu. See Section 4.3 *The MODE Menu*. For example, if the analyzer is currently set on range 2 which has been defined as 0–100 ppm CO<sub>2</sub>, and the MODE is set to LINEAR, then the output would be:

PPM CO <sub>2</sub>	SIGNAL OUTPUT Voltage (V)	OPTIONAL 4–20 MA OUTPUT CURRENT (MA)
0	0	4
10	0.1	5.6
20	0.2	7.2
30	0.3	8.8
40	0.4	10.4
50	0.5	12.0
60	0.6	13.6
70	0.7	15.2
80	0.8	16.8
90	0.9	18.4
100	1.0	20.0

**I/O BOARD SWITCH POSITIONS FOR VOLTAGE OUTPUT**

S1-1	S1-2	S1-3	S1-4	IR Volt	O <sub>2</sub> Volt
OFF	OFF				1V.
OFF	ON				5V.
ON	ON				10V.
		OFF	OFF	1V.	
		ON	ON	5V.	
		ON	ON	10V.	

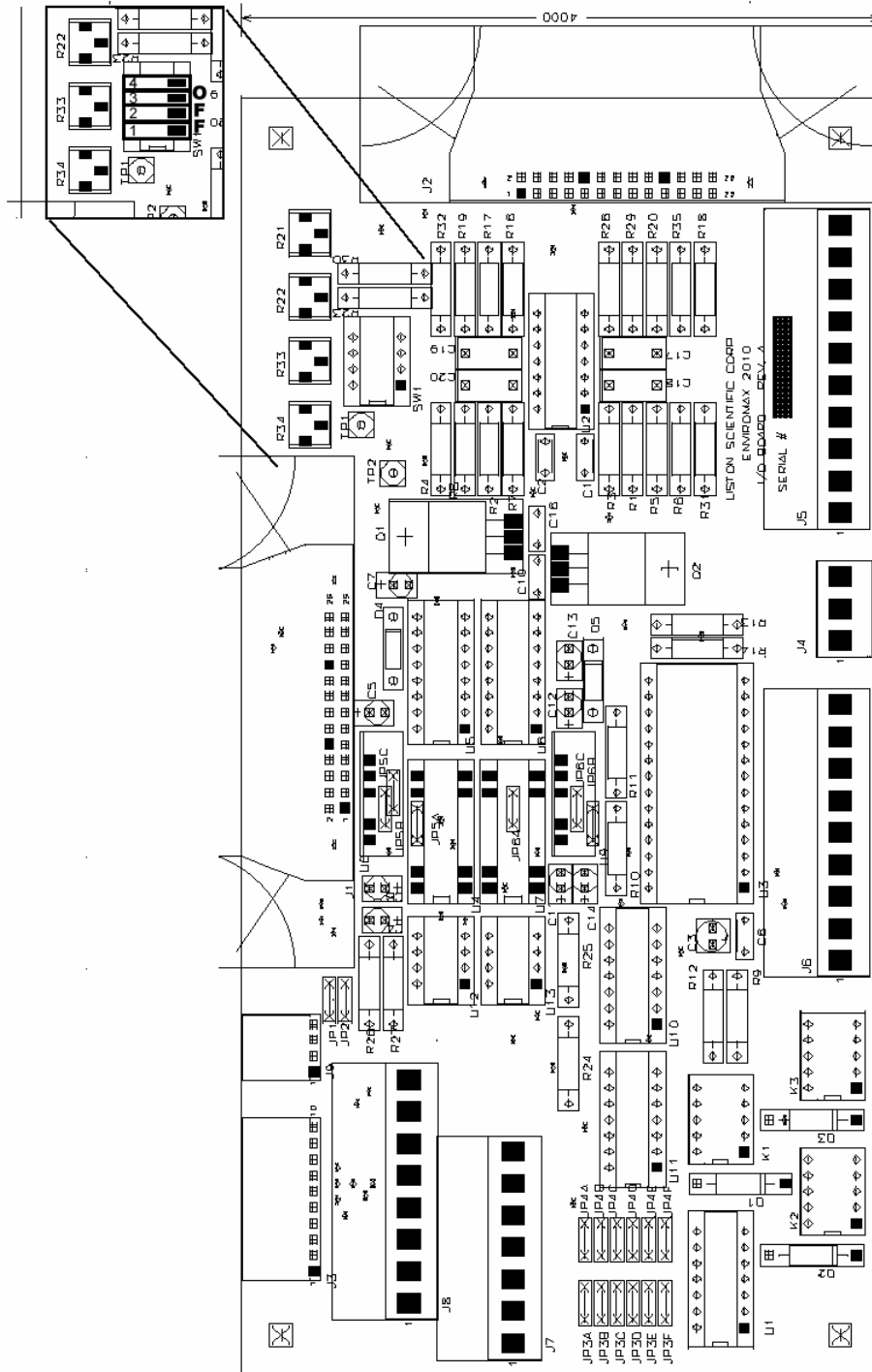

Figure 3-6: Location of Slide Switch S1 on I/O Board

### 3.6.2 Analog Output Connections

Output signals from the IR section of the analyzer are available from the 2 leftmost terminals on the long connector labeled INFRARED CHANNEL 1. Attach the wires from the output device to the connector at the terminals labeled VOLT OUT/IR. Make sure the proper polarity is observed.

If an O<sub>2</sub> channel is installed, connect the 2 wires from the device used to monitor the O<sub>2</sub> concentration to the terminals labeled VOLT OUT/O<sub>2</sub>. Again, observe proper polarity.

If the current output option is installed, connect the 2 wires from the current driven output device to the terminals labeled mA OUT/IR using the indicated polarity. Repeat for the O<sub>2</sub> channel at the terminals labeled mA OUT/O<sub>2</sub>.

### 3.6.3 Solenoid Valve Connections

To use the automatic calibration feature of this instrument a pair of AC solenoid valves must be installed on the sample system. If not installed by the factory, the customer is responsible for obtaining and installing the valves into the sample system. Refer to Figures 3-1 and 3-2 for suggested placement. The solenoid valves are driven by isolated triacs. The triacs can handle a maximum rated load of 0.6 A at instrument voltage.

The factory recommends using 2 3-way valves to control the sample and calibration gas flow through the analyzer. See Figure 3-1 and 3-2 for suggested sample system valve layouts.

To install the electrical connections of the solenoid valves, refer to **Addendum “B”** at the back of this manual.

The sense of the valve — flow when energized or flow when de-energized — depends of the disposition of the 3-way valve in the sample system. The sense must be correct for your application. When the autocalibration feature is called by the microprocessor to begin a ZERO calibration, the solenoid connected to the terminal labeled ZERO will be **energized**. The solenoid connected to the SPAN terminal will be **de-energized**. See Table 3-1 for the solenoid valve status during autocalibration for the suggested sample systems given in Figures 3-1 and 3-2.

*NOTE: The customer is responsible for supplying and installing the sample system if one has not been provided by LSC. Liston cannot be responsible for improperly designed or fabricated sample systems. If questions arise regarding the suitability of a sample system or sample system component, consult Customer Service for guidance.*

<b>FLOW</b>	<b>VALVE</b>	<b>SOLENOID STATUS</b>
Zero Gas	A	energized
	B	de-energized
Span Gas	A	de-energized
	B	energized
Sample Gas	A	de-energized
	B	de-energized

*Table 3-1: Solenoid Status for Gas Flows*

For the explosion proof and split-architecture models, provisions are made for controlling 3 AC solenoid valves in the sample system. A similar valve layout as shown in Figure 3-1 and 3-2 can be used for deploying 2 3-way valves for controlling calibration and sample gases. Alternatively, one can use 3 2-way valves with a valve on each line (sample, zero and span). See also the application shown in Figure 3-3.

Connections from the solenoid valves are made to the rear panel on the control unit.

**3.6.4 Optional Relay Outputs**

AC / DC relays are available as an option on the IR7000 series of analyzers. This option is not available for the portable model. If the optional relays (K1, K2, K3) have been installed, the sets of connections on the rear panel will be functional. Each relay is a single pole, double throw relay and provides a common (C), normally closed (NC) and normally open (NO) terminals for connection to the users equipment (alarm lamps, annunciator, or other control, warning or recording devices).

The relays are normally tied in to the high limit alarm, low limit alarm, and failure alarm outputs during assembly. They can be coupled to other outputs by cutting and installing jumpers on the main board. Consult the factory for more information on altering the default relay coupled output.

The relay outputs can be used to switch up to 1 A at 60 VDC or 30 VAC.

### 3.6.5 Digital I/O Option

The Digital Input/Output option provides opto-isolated digital input and output capability for controlling functions of the analyzer.

The outputs indicate:

- The current range in use
- If a calibration is in progress
- Whether an audible alarm has triggered
- High and low limit/alarm status
- Fault alarm status

The inputs are used to:

- Initiate a zero and/or span calibration

Each output is the collector and emitter of a phototransistor. The customer must provide a voltage to each collector and a resistor to limit the current (100 mA maximum per device). The outputs can switch 100 mA at 25 V. See the Option Board Schematic in the Reference Section of this manual.

The digital inputs supplied by the customer are used to drive LED's. The customer must supply a voltage to each LED and a current limiting resistor. A minimum of 10 mA is required by the LED's. Do not exceed 20 mA. The forward voltage drop is 1.5V.

The Digital I/O connector mounted on the rear panel of the instrument is an industry standard metal shell 24 pin ribbon connector. The contact spacing is 2.16 mm (0.085 in) center to center. The customer must fabricate the cable and mating connector. One source for the mating connector is Thomas & Betts Co. P/N 622-24FM.

Table 3-2 shows the pin connections for the connector mounted on the rear panel. Table 3-3 indicates the logic used in the range selection and identification.

PIN #	FUNCTION	PIN #	FUNCTION	IN/OUT
1	Range Bit 0 +	2	Range Bit 0 -	Output
3	Range Bit 1 +	4	Range Bit 1 -	Output
5	Doing Cal +	6	Doing Cal -	Output
7	Alarm/Limit 1 +	8	Alarm/Limit 1 -	Output
9	Alarm/Limit 2 +	10	Alarm/Limit 2 -	Output
11	Audible Alarm +	12	Audible Alarm -	Output
13	Spare1+	14	Spare1 -	Input
15	Spare2 +	16	Spare2 -	Input
17	Not Used	18	Not Used	
19	Cal Req. Full/Zero +	20	Cal Req. Full/Zero -	Input
21	Cal Req. Span +	22	Cal Req. Span -	Input
23	Fault +	24	Fault -	Output

Table 3-2: Digital I/O Connector Pin Out

CHART RANGE	BIT 0	BIT 1
1	Off	Off
2	On	Off
3	Off	On
4	On	On

Table 3-3: Range ID Logic Table

Installation involves:

- Fabricate the I/O cable with mating connector.
- Mate cable and connector to the rear panel.
- Connect opposite end(s) of cable to the input and output devices.

### 3.6.6 RS-232 Cable

An optional serial port is available for communication to and from a remote computer. The port is a standard RS-232 serial communications port and allows the user to input control functions and output data in response to a variety of requests. A standard DB-9 male connector is mounted on the rear panel for connection to a remote PC computer via a

Null Modem cable. The pin assignment for the DB-9 connector is shown in Figure 3-7.

The RS-232 communication parameters are fixed at:

Parameter	Setting
Baud	2400
Byte	8 bits
Parity	none
Stop Bits	1

The description of the RS-232 communication protocol is given in the Appendix.

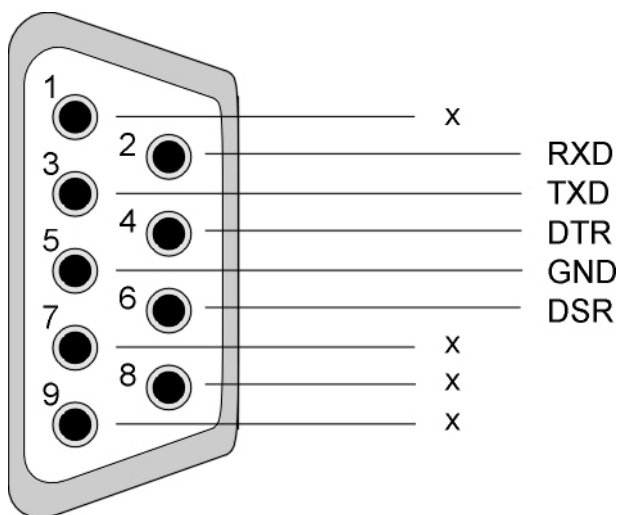

*Figure 3-7: RS-232 Pin Assignment*

**3.6.7 Power Connections**

The IR7000 is shipped configured for 120 or 230 VAC operation.

After all other electrical and gas connections have been made, connect the AC power to the power entry module on the rear panel.

The analyzer can now be powered up for testing gas connections, solenoid operation and internal functions through the power-on self diagnostic test.

If the instrument successfully powers up with no error messages and there are no gas connection or solenoid activation problems, the analyzer

can be configured for operation using the SETUP and MODE buttons on the front panel. Refer to Section 4 for entering SETUP and MODE parameters.

## Operation

---

### 4.1 Overview

There are 4 steps involved in operating the IR7000 NDIR Gas Analyzer:

1. Initial warm up—the analyzer must be powered up and stabilized before introducing a sample for analysis. The optimum warm up time is 3 hours although the instrument can be used after 1 hour.
2. Configuring the instrument for your application using the SETUP function. This can be done during the warm-up period if desired.
3. Setting operational parameters via the MODE function.
4. Calibrating the instrument with zero and then span gas. Section 5 describes calibration in detail.

### 4.2 The SETUP Menu

Once the analyzer has been installed, gas lines connected and electrical connections made, the IR7000 can be configured for your application. Refer to Section 3 for installation procedures. Configuring the instrument involves:

- Entering span gas concentration(s)
- Activating automatic calibration function and frequency
- Setting chart recorder or output ranges
- Entering alarm set points
- Selecting Cal Delay (flush time)

These parameters are entered into the instrument by accessing the SETUP menus from the front panel. See Figure 4-1. They can be entered in any order.

To enter setup information into the instrument press and hold in the SETUP button. This brings you to the 1st SETUP submenu. Make your selection between the available options, or change the value for that

submenu using the UP ( $\Delta$ ) or DOWN ( $\nabla$ ) buttons To access the next submenu within the SETUP menu, release the SETUP button then press the SETUP button again. This cycles through the submenus one at a time.

To configure the instrument for your application, follow the steps outlined below.

**CAUTION:** Make sure that the power cord is attached and the instrument is properly grounded. Make sure that there are no leaks in the sample system. Ensure that the inlet pressure of the sample gas is less than 5 psig and stable.

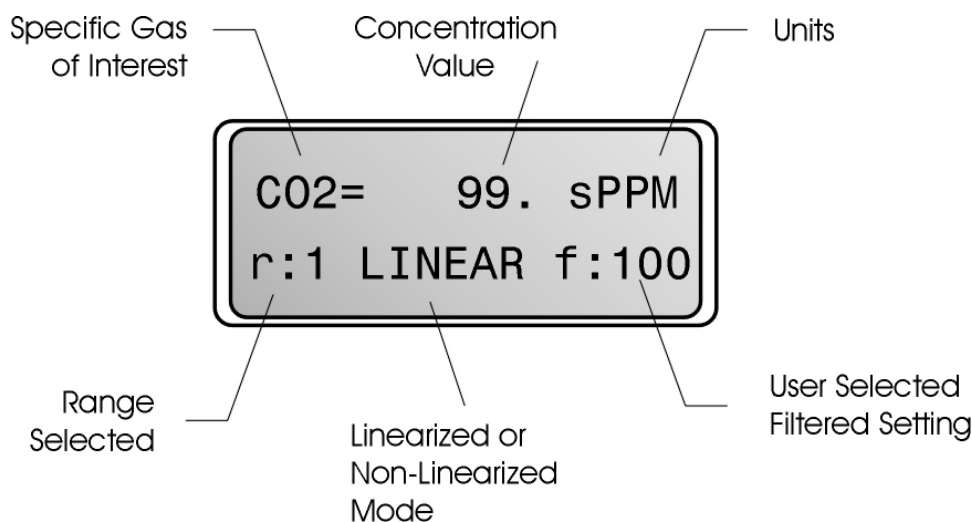

Figure 4-1: SETUP and MODE Menus

*SETUP*

- Cal Gas*
- Full Auto*
- Range (1-4)*
- Alarm L*
- Alarm H*
- Cal Delay*
- O2 Cal Gas*

*MODE*

- Calibrate*
- Chart =*
- Filter =*
- Calibration Hold/Track*
- Linear/Non linear*
- Bright =*
- Alarm = On/Off*
- Auto = Full/Zero*

1. TURN ON THE POWER

The instrument will initiate a power-on self-diagnostic test. It will briefly display the initial start-up messages. If the self-test is successful, the first message will indicate that a battery backup memory fetch was successful and any previously saved configuration settings will be retrieved and set as the current configuration. If this configuration is the desired setup for your analysis session, go to Section 4.3 *MODE Menu*. If this is the first session or you need to edit any or all of the configuration settings, continue on with step 2. The next start-up screen which automatically appears on the display identifies the model and serial number of the instrument. This screen will be followed by a third screen which identifies the US patent number of the instrument and software version installed. Finally the analysis screen will appear with a display as shown in Figure 4-3 and the example screen on the left. The analysis screen indicates:

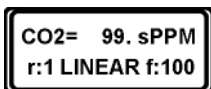
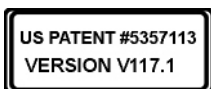
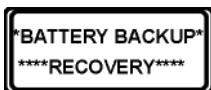

- The gas of interest (CO<sub>2</sub> in the example screen)
- An initial reading (ignore this for the present time)
- R:1 — analog range (range 1 for this example)
- LINEAR—indicating that the indicated gas concentration has been linearized before being displayed.
- f:100 — indicating the amount of filtering being applied to the measurement. See Section 2.3.3.

2. ENTER THE SPAN GAS CONCENTRATION

Press and hold the SETUP button to enter the CALGAS submenu.

The CALGAS submenu allows you to specify the concentration of your span gas. Note that you cannot change the span gas, only the concentration of the gas.

*NOTE:* You must continue to hold in the SETUP button while you edit or enter information into the display. Releasing the SETUP button will take you back to the ANALYSIS screen. Pressing the SETUP button again will cycle you to the next submenu item in the SETUP menu. In order to get back to the menu you were working in, cycle through all 5 or 6 (depending on the model) submenus.

The sequence of submenus available from the SETUP main menu are as follows:

SUBMENU	DESCRIPTION
CAL GAS	Enter concentration of span gas
FULL AUTO	Set automatic calibration “ON” or “OFF” And time span between auto-calibrations
Chart 1	Set upper bound of analysis range 1.
Chart 2	Set upper bound of analysis range 2.
Chart 3	Set upper bound of analysis range 3.
Chart 4	Set upper bound of analysis range 4.
Alarm L	Set Alarm 1 threshold (LOW alarm).
Alarm H	Set Alarm 2 threshold (HIGH alarm).
CAL DELAY	Set delay between request for calibration and actual start of calibration. Used to purge cell before calibrating.
O2 CAL GAS	If present, enter concentration of O2 span gas.

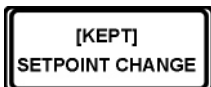
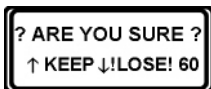
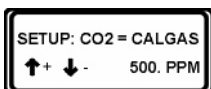

- Enter the Span Gas Concentration.** Use the UP and DOWN arrows on the front panel while holding in the SETUP button to change the actual concentration of your span gas. The value on the lower right of the screen will change as you press either arrow. Note that after 10 units up or down, the longer you hold in an arrow, the faster the value changes. Stop when you are close to the correct concentration for your span gas and then resume by pressing the UP (Δ) or DOWN (∇) arrow again for the final slow approach to the correct value.
- Save the changes.** The SAVE or LOSE screen will automatically appear when you release the SETUP button. It will prompt you to press Δ or ∇ to save or lose the changes. You have 60 seconds to either save or discard your changes. The default value is discard. When the changes are discarded, either the default instrument values or the last saved values will be set.

3. **ENTER AUTOMATIC CALIBRATION FREQUENCY (If enabled)**

Press and hold the SETUP button to enter the number of hours between automatic calibrations. Automatic calibrations requires that the analyzer be connected to externally powered solenoid valves. The type of automatic calibration (either zero or full) is selected in the MODE menu.

NOTE: In a dual analyzer this menu selection will not appear in the second IR channel (referred to as “slave”) and is also not present in the battery portable model.

4. **DEFINE RANGES**

Press and hold the SETUP button to enter the Range 1 submenu. If necessary, cycle through the submenus by repeatedly pressing the SETUP button until the CALGAS menu appears. Then press and **hold** the SETUP button once more to enter the CHART 1 submenu.

NOTE: *The dynamic range of the IR7000 detector is 1000:1 which means that it can respond to a 1 PPM change in a sample containing 1000 PPM. This is fixed by the design of the detector and is independent of the range setting. The 4 user definable ranges are implemented mainly to accommodate standard output devices such as chart recorders. The full output 0–1V, 0–5V or 0–10V (or optionally, 4–20mA) will be linearly scaled over the defined chart range.*

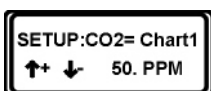

- **Enter Range 1.** Use the UP and DOWN arrows on the front panel while holding in the SETUP button to enter or change the upper bound of the CHART 1 range.

NOTE: *The 4 user definable ranges must be consecutively increasing. That is, the upper bound on each successive range must be greater than the previous range’s upper bound. Range 4 ≥ Range 3 ≥ Range 2 ≥ Range 1.*

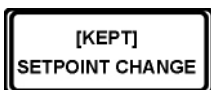
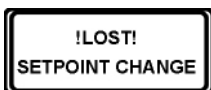
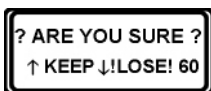

- **Save changes.** As before, once you release the SETUP button you will be prompted to save or else lose any changes you made. There is a 60-second timer on this screen. Press the UP button to save your changes or the DOWN button to discard the changes within the 60-second time limit. A confirmation screen will then appear.
- **Set the other ranges.** If desired, toggle to the next submenu (CHART 2) and continue in a similar fashion

until all 4 ranges have been defined. It is not necessary to set all 4 ranges in order to use the instrument.

5. ENTER ALARM SETPOINTS

The next 2 submenus allow the user to enter low and high alarm setpoints respectively. Press and hold the SETUP button until the ALARM L submenu appears. If necessary, cycle through the submenus by repeatedly pressing the SETUP button until the CHART 4 menu appears. Then press and hold the SETUP button once more to enter the ALARM L submenu for editing.

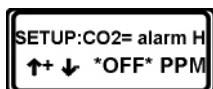
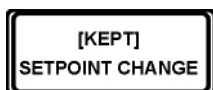
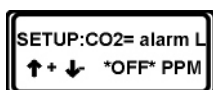

- **Enter the low alarm setpoint.** Use the UP and DOWN arrows on the front panel while holding in the SETUP button to enter or change the low alarm setpoint. An alarm setpoint of 0 turns the alarm off. The OFF status or the setpoint will be reflected on the bottom line of the display.
- **Save changes.** Again, after releasing the SETUP button, you will be prompted to save or else lose any setpoint changes you made. There is a 60-second timer on this screen. Press the UP button to save your changes or the DOWN button to discard the changes within the 60-second time limit. A confirmation screen will then appear.
- **Enter the high alarm setpoint.** Go to the next submenu (ALARM H) to set the high alarm setpoint. Use the UP and DOWN arrows on the front panel while holding in the SETUP button to enter or change the high alarm setpoint. As before, an alarm setpoint of 0 turns the alarm off.

6. ENTER CALIBRATION DELAY TIME

The next submenu, CAL DELAY, is used to specify the time delay before the start of a calibration. The time delay begins when the calibration is requested either manually or through the autocalibration feature. During the delay, the sample cell should be purged with zero or span gas depending on the particular calibration.

Without this delay, or if the delay is set too short, it is possible to generate calibration errors. In most cases the instrument will attempt to recalibrate. After 5 recalibration attempts the instrument will generate a LOW CALIB FLOW ALARM. If this occurs, see Section 6.3.1.

*NOTE: The CAL DELAY submenu is not present on the battery operated portable instrument.*

*NOTE: Autocalibration is not available on the battery operated portable model.*

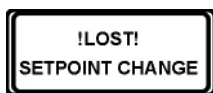
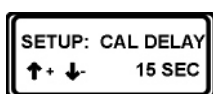

- **Set calibration delay time.** Use the UP and DOWN arrows on the front panel while holding in the SETUP button to enter or change a delay period.
- **Save changes.** After entering a value and releasing the SETUP button, you will be prompted to save or else lose the changes you made. There is a 60-second timer on this screen. Press the UP button to save your changes or the DOWN button to discard the changes within the 60-second time limit. A confirmation screen will then appear.

To determine the optimum delay time, initiate a manual span calibration (see Section 5 *Calibration*) and while watching the display, note the time it takes to reach a stable span calibration reading. Add 10% to this reading and use this value for the CAL DELAY.

*NOTE: In models with dual optical benches, the CAL DELAY value must be the same for both channels.*

When performing a manual calibration, if the calibration flow has already been established and stable readings exist, set the CAL DELAY to 15 seconds (60 seconds for trace instruments).

During the calibration event, if the instrument detects a change in the gas concentration, it will automatically attempt to recalibrate. This could occur for example, if there is a leak in the sample system upstream of the detector. If after 5 attempts at calibration the system still detects an unstable concentration, a LOW CALIB FLOW alarm will be indicated on the display. If this occurs, refer to Section 6.3.1.

7. ENTER THE O<sub>2</sub> SPAN GAS CONCENTRATION

Press and hold the SETUP button to enter the O2 CAL GAS submenu.

*NOTE: The O<sub>2</sub> analysis feature is an option and not present on all models. On instruments without this feature, there will not be an O2 CAS GAS screen.*

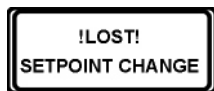
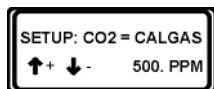

- **Input the O<sub>2</sub> span gas value.** Use the UP and DOWN arrows on the front panel while holding in the SETUP button to enter the actual concentration of your span gas. The value on the lower right of the screen will change as you press either arrow.
- **Save changes.** Again, after releasing the SETUP button, you will be prompted to save or else lose any setpoint changes you made. There is a 60-second timer on this screen. Press the UP button to save your changes or the DOWN button to discard the changes within the 60-second time limit. A confirmation screen will then appear.

### 4.3 The MODE Menu

Operational parameters of the analyzer are established through the MODE menu. From the MODE menu you can:

- Initiate a calibration (zero, span, or both).
- Set which user-defined or default chart range to use, or let the instrument select the range automatically using the auto-ranging feature.
- Select the amount of filtering to be applied to the measurement.
- Select whether the instrument tracks the gas reading during a calibration or holds the last reading prior to the calibration cycle.
- Select whether the readings are linearized or nonlinearized.
- Set the contrast of the display.
- Toggle the alarm feature on or off.
- Select either a full (zero and span) or zero only automatic calibration.

The MODE submenus are displayed and their functions are set in the same manner as the SETUP features were: **hold** in the MODE button and use the UP and DOWN button to select the appropriate value or selection. Releasing the MODE button and pressing it again brings you to the next submenu. Figure 4-1 shows the MODE submenus in the order in which they will appear on screen.

#### 1. CALIBRATE

The first submenu of the MODE menu is the CALIBRATE submenu. It allows the operator to initiate a calibration event. The operator can select either a zero, span or full calibration (zero and span). The calibration event will begin after a delay as defined in the SETUP/CAL DELAY submenu. See Section 4.2 *SETUP Menu* and Section 5 *Calibration*.

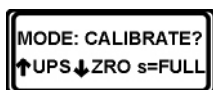

- **Select the calibration event.** Press the UP button (UPS) to select a span calibration. Press the DOWN button (ZRO) to select a zero calibration. Press the SETUP button to select a full calibration (both zero and span).

**NOTE:** Select *FULL* only when properly setup for performing automatic calibration. See Section 3 Installation. The *FULL* selection is not available on the battery operated portable model.

The calibration will initiate after releasing the UP or DOWN arrows subject to the calibration delay period which was entered in the CAL DELAY submenu during SETUP.

**NOTE:** In the battery portable model, manually switch over to zero or span calibration gas to purge the sample cell before pressing the UP or DOWN buttons.

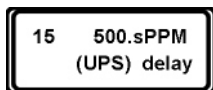
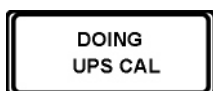

The screen will indicate which calibration is to be performed and then change to the countdown screen indicating the time remaining in the CAL DELAY function. The time remaining is shown in the upper left of the display and “delay” is indicated at the lower right. The concentration of the gas in the sample cell is also displayed on the top row.

**NOTE:** To optimize the CAL DELAY function, you can initially set the CAL DELAY function to some high value, for example 120 seconds. Refer to Section 4.2 for setting the CAL DELAY period. Then, time the calibration while observing the display as it changes. Note the time in seconds it takes for the concentration reading to stabilize. Add 10% to this value and reenter it into the CAL DELAY submenu of the SETUP menu.

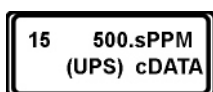

After the CAL DELAY period has elapsed, the calibration begins. Data is collected and averaged over 20 seconds. If an unstable reading is obtained, the instrument will automatically recalibrate for another 20 seconds. The instrument will attempt a recalibration up to 5 times and if it cannot find a stable calibration value it will either restore the old calibration value or enter into an alarm mode. See Section 6.3.1 for alarm messages and procedures.

**2. SELECT CHART RANGE**

The next submenu is used to select the chart output range the instrument will use during analysis. The ranges can be user-defined however the instrument will default to standard ranges preset at the factory if no user-defined ranges have been setup. See Section 4-2 for information on how to set up the chart ranges. The analyzer is equipped with an autoranging feature which will automatically select the correct chart range during the measurement.

- **Enter the desired range or select autorange.** Press the MODE button repeatedly until you reach the CALIBRATE? submenu. Press and **hold** the MODE button one more time to lock onto the CHART submenu.

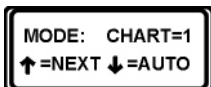

There are 2 mutually exclusive choices to make from this submenu: FIXED range or AUTO. If you are using a FIXED range, the top line of the display will indicate the currently selected range (1–4). See the example screen on the left. When FIXED is in effect, you can change to the next range by pressing the UP button or enter the AUTO mode by pressing the DOWN button.

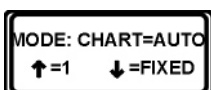

If AUTO range is selected, the display will indicate AUTO. You can change back to FIXED range by pressing the DOWN button. Pressing the UP button will also place you in FIXED mode and will select the range indicated on the lower left in the display.

### 3. FILTER

The FILTER submenu allows the operator to choose the amount of filtering that is applied to the measurement. There are 3 filter settings available: 1, 10, 100 (10, 100, 1000 for trace instruments). The response time of the analyzer is related to the filter number. Choosing a lower filter number results in a faster response, however higher filtering yields a smoother measurement.

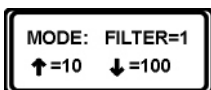

- **Enter a filter value.** Press the MODE button repeatedly until you reach the CHART submenu. Press and **hold** the MODE button one more time to lock onto the FILTER submenu. Use the UP or DOWN arrows to toggle through the available filter settings. The filter value will be indicated on the top line of the display. Releasing the MODE button will set the filter value.

#### 4. CAL TRACK OR HOLD

The TRACK/HOLD submenu selection determines how the display and output signal behave during a calibration. If TRACK is selected, the output signal and display will change with the measured value of the gas during calibration. If HOLD is selected, the output signal and display will remain fixed at the last measurement prior to the calibration.

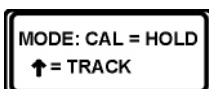

- Select Cal TRACK or HOLD. Press the MODE button repeatedly until you reach the FILTER submenu. Press and **hold** the MODE button one more time to lock onto the CAL=TRACK/HOLD submenu. Initially, the default setting of HOLD is set and displayed on the screen. Use the UP arrow to toggle between TRACK and HOLD. Releasing the MODE button enters the selection displayed on the screen.

**NOTE:** *If the instrument is set to CAL = HOLD, there will be no change in display or output of the calibration value, it will hold on the last measured value before the calibration command was given. At the end of the calibration event, there will be another delay in output equal to the CAL DELAY period while the gas concentration in the sample cell changes from pure calibration gas to actual sample gas. If the calibration has changed since the last calibration, there will be a jump in the reading as the new calibration takes effect. See Figure 4-3.*

*If the instrument is set to CAL = TRACK, the display and output will change as the gas concentration changes. At the end of the calibration event, there will NOT be a another delay in output equal to the CAL DELAY period. The display and output will show the changing gas composition as the cell adjusts itself from calibration gas to actual sample. If the calibration has changed since the last calibration, jump in the reading as the new calibration takes effect. See Figure 4-4.*

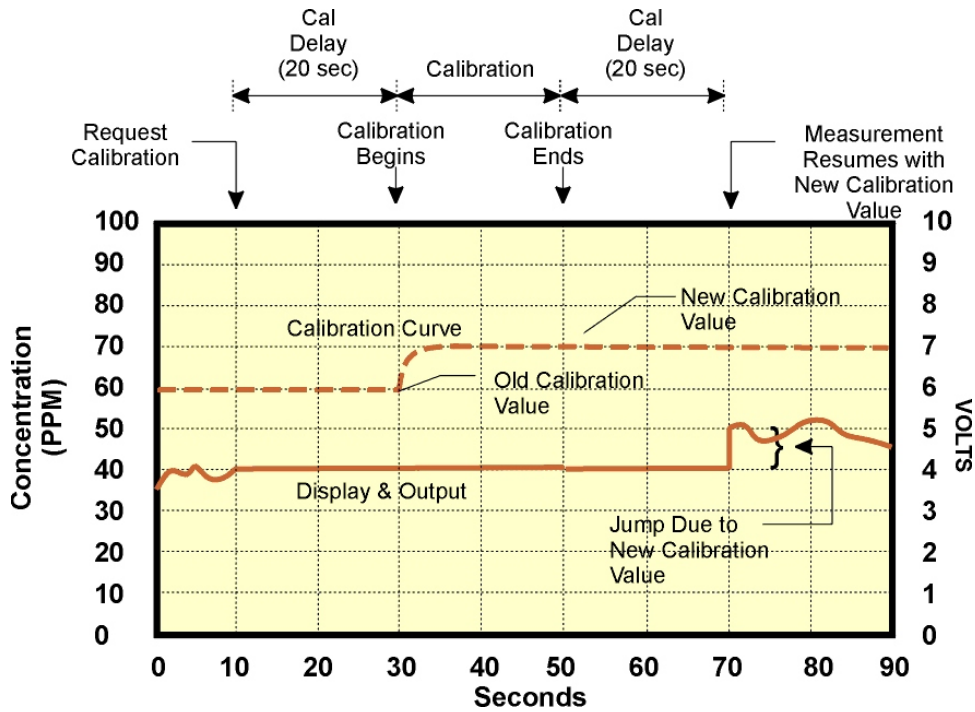

Figure 4-3: Output Jump After New Calibration, CAL=HOLD

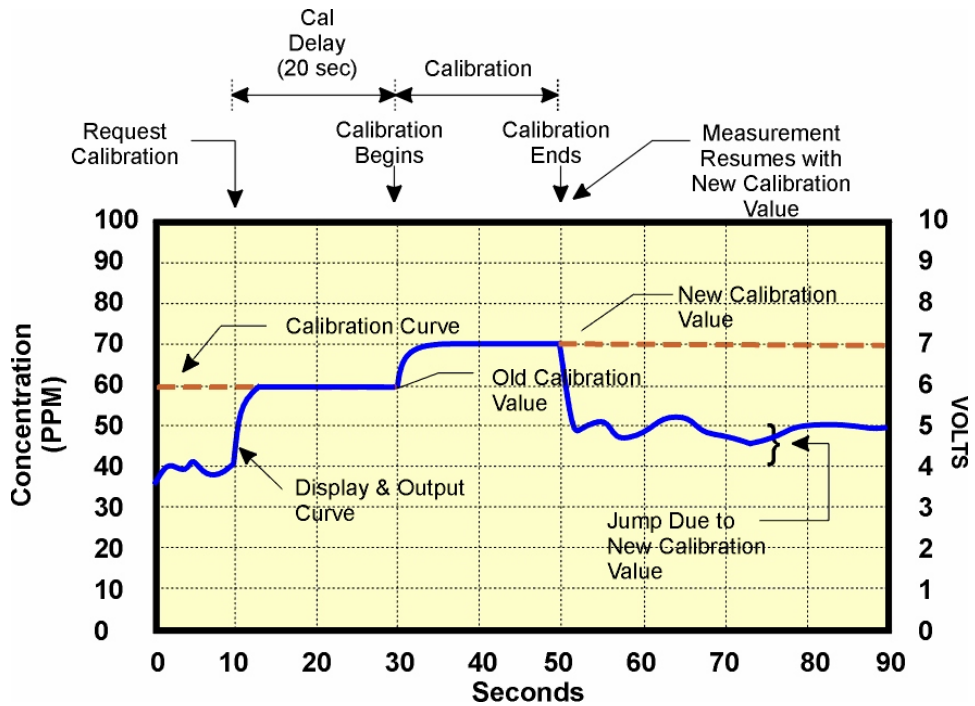
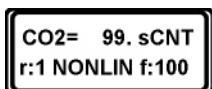
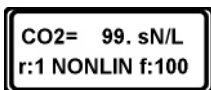
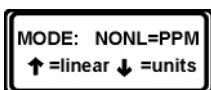
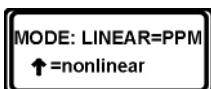

Figure 4-4: Display & Output Jump After New Calibration, CAL=TRACK

5. LINEAR/NONLINEAR MODE



The choices in this submenu effect whether the output data (display and output) are linearized or not. For accurate readings, it is recommended that you leave this function set to LINEAR.



- **Set Linear or Nonlinear Data.** Press the MODE button repeatedly until you reach the CAL TRACK/HOLD submenu. Press and **hold** the MODE button one more time to lock onto the LINEAR/NONLINEAR submenu. Use the UP arrow to toggle between the LINEAR and NONLINEAR setting. If you choose NONLINEAR, you have the additional option of selecting either PPM or counts as the displayed units of measure. Use the UP and DOWN arrows to select the desired units. Releasing the MODE button will bring back the analysis screen which reflects your data mode choice and the units of measure. See the example screens on the left.

6. DISPLAY BRIGHTNESS

The relative brightness of the vacuum fluorescent display is adjustable over 4 levels using the BRIGHT submenu.

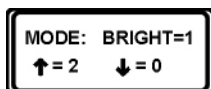

- **Select the display brightness.** Press the MODE button repeatedly until you reach the LINEAR/NONLINEAR submenu. Press and **hold** the MODE button one more time to lock onto the BRIGHT submenu. Use the UP or DOWN arrows to toggle through the 4 levels (0–4) of brightness settings. The display will immediately respond to your selection.

## 7. ALARM OFF/ON

The high and low alarms may be toggled ON or OFF by the operator.

- **Set alarm status.** Press the MODE button repeatedly until you reach the DISPLAY submenu. Press and **hold** the MODE button one more time to lock onto the ALARM submenu. Use the UP arrow to turn the alarms ON or OFF.

**WARNING:** It is not recommended that you operate this instrument with the alarms defeated. This function is implemented primarily for maintenance convenience. If the application in which this instrument is to be used involves the monitoring and/or control of a dangerous gas, switching the alarm status to OFF can seriously impair the instrument to perform its function of warning or controlling a potentially hazardous situation.



## 8. AUTO FULL/ZERO

Automatic calibrations can be selected to be either zero only or zero and span.

- Use the “up” arrow button to select either a zero or full (zero and span) automatic calibration at the intervals selected in the SETUP menu under FULL/AUTO.

**Flow Diagram A**

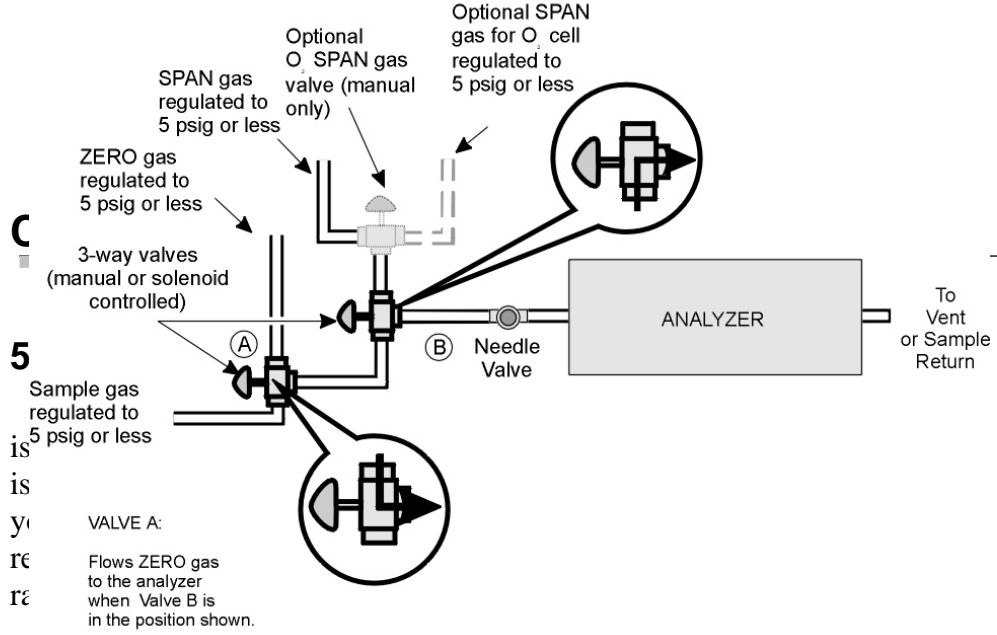

**Flow Diagram B**

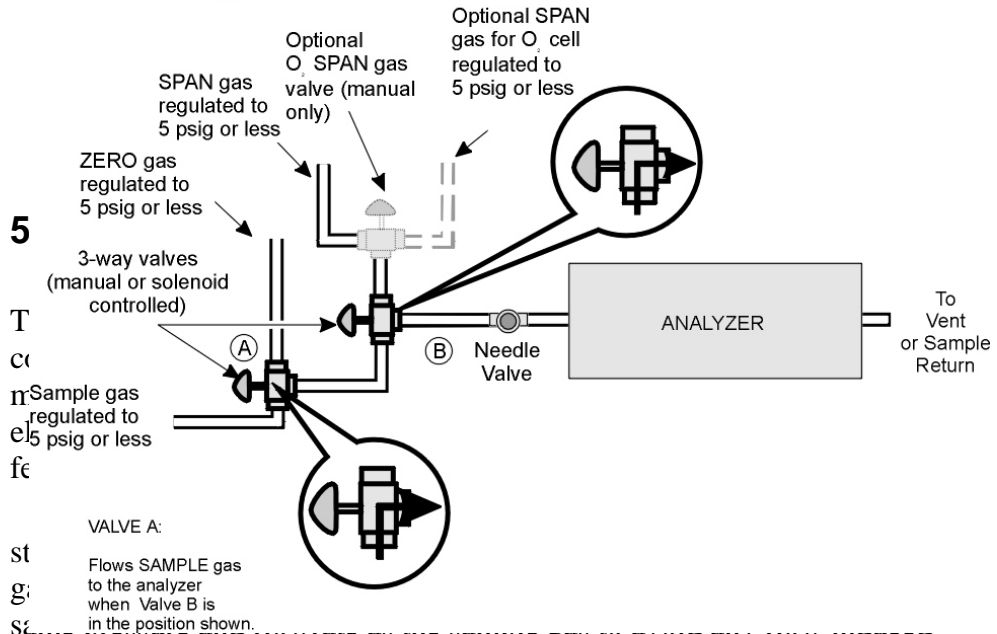

variables which could affect the calibration. It is highly recommended that the calibration gas sources use a regulator and flow control device (inline needle valve or flow meter with integral needle valve)

*Figure 5-1A & B: Flow Diagram for Manual Calibration*

 **CAUTION:** The inlet gas pressure must be less than 5 psig. Do not exceed 5 psig. The sample cell is not designed to withstand pressurization in excess of this. Make sure there are no kinks, tight bends, or other obstructions in the sample system that could generate excessive backpressure.

The standard models are equipped with an automatic calibration feature which allows zero, span, or both calibrations to be performed automatically. The user can also select the frequency of automatic calibration. See Section 4.2 for details in setting up the instrument for preprogrammed calibration events.

### 5.3 Manual Calibration

It is possible to manually calibrate the instrument at any time even if an auto calibration period has been set. In order to obtain a valid calibration, the sample cell must be purged of sample gas. This is conveniently handled by having an appropriate CAL DELAY value configured into the instrument via the SETUP function. See Section 4.2 *SETUP Menu*, for procedures involved in setting the CAL DELAY.

With an appropriate CAL DELAY set, make sure that the calibration source pressure is the same as the sample gas pressure and less than 5 psig.

*NOTE:* The pressure in the sample cell during calibration must be the same as when flowing sample gas. Both the IR detector and the optional oxygen sensor are sensitive to significant pressure or flow variations.

#### 5.3.1 Manual Zero Calibration

A manual zero calibration involves:

1. Stopping the sample flow and switching to zero gas
2. Purging the sample cell with zero gas
3. Using the CALIBRATE?/ZERO submenu of the MODE menu to request a manual zero calibration.

To manually zero calibrate the analyzer:

- Referring to the flow diagram in Figure 5-1A, manually switch the 3-way valve from sample gas to ZERO gas. Make sure that valve B is set to flow gas in the position shown in the inset.
- While watching the flowmeter, use the needle valve to adjust the flow to 1.5 SCFH or to the same flowrate that is used for sample gas.

- Using the MODE button, navigate to the CALIBRATE? submenu and while holding in the button, press the DOWN button to initiate a zero calibration.
- After the CAL DELAY period the instrument will go into calibration mode and the display will read “DOING ZERO CAL”. Calibration data will be collected for 20 seconds.
- After the 20 second calibration, if a manual span calibration is to follow, switch valve A to sample gas and valve B to SPAN. Otherwise, switch valve A to sample gas and leave valve B in the position shown in the inset. This will allow the sample gas to flow.

At this stage, the composition of the gas in the sample cell is pure zero gas. Purge the cell by allowing span or sample gas to flow for a sufficient time.

**NOTE:** *If the TRACK/HOLD function has been set to HOLD (see section 4.3), then there will be no change in the screen display and the output will remain fixed on the last reading taken before entering the calibration. At the end of the 20-second calibration there will be another delay equal to the time delay set in CAL DELAY. This delay is used to allow sample gas to purge the sample cell of zero gas before the instrument resumes monitoring. It is important to close the zero gas valve and open the sample gas valve during this delay to ensure sufficient purging has occurred before monitoring is resumed.*

If a problem is encountered during calibration and the instrument cannot calibrate, the data from the last successful calibration will be restored, if possible. A series of messages will be displayed on the screen informing the user why the calibration failed and if the old values have been restored. See Section 6 *Maintenance*.

**CAUTION:** This analyzer will zero calibrate to almost any gas. It will even zero calibrate to your sample or span gas! If the wrong gas is used for zero calibration, it is almost certain that the instrument will fail in span calibration and/or generate unusable data. Make absolutely certain that zero gas is flowing in the cell during the zero calibration by double checking the valve status and watching the flow meter on the front panel.



### 5.3.2 Manual Span Calibration

**CAUTION:** It is important to use a valid SPAN gas for calibration. The concentration of the span gas must be greater than 50% of the full range of the instrument, preferably 80%.



A manual span calibration is similar to the manual zero calibration. It involves:

1. Stopping the sample flow and switching to span gas
2. Purging the sample cell with span gas
3. Using the CALIBRATE?/UPS submenu of the MODE menu to request a manual span calibration.

**NOTE:** *Before span calibration can be performed, the correct concentration of the span gas must be entered in the SETUP/CALGAS submenu. If this value has been previously entered it will be recalled during startup. You will not need to reenter it unless the memory backup failed.*

To SPAN calibrate your instrument manually:

- Referring to the flow diagram in Figure 5-1B, make sure that the 3-way valve labeled A is set to flow SAMPLE gas. Manually switch valves B to flow SPAN gas.
- While watching the flow meter, use the needle valve to adjust the flow to 1.5 SCFH or to the same flowrate that is used for sample gas.
- Using the MODE button, navigate to the CALIBRATE? submenu and while holding in the button, press the UP button to initiate an upscale (UPS) span calibration.
- After the CAL DELAY period the instrument will go into calibration mode and the display will read “DOING UPS CAL”. Calibration data will be collected for 20 seconds.
- After the 20 second calibration, close the span gas valve and open the sample gas valve to reinstate the sample gas flow. At this stage, the composition of the gas in the sample cell is pure span gas. Purge the cell by allowing span or sample gas to flow for a sufficient time.

**NOTE:** *If the TRACK/HOLD function has been set to HOLD (see section 4.3), then there will be no change in the screen display and the output will remain fixed on the last reading taken before entering the calibration. At the end of the 20-second calibration there will be another delay equal to the time delay set in CAL DISPLAY. This delay is used to allow sample gas to purge the sample cell of span gas before the instrument resumes monitoring. It is important to close the calibration gas valve and open the sample gas valve during this delay to ensure sufficient purging has occurred before monitoring is resumed.*

If a problem is encountered during calibration and the instrument cannot span calibrate, the data from the last successful calibration will be restored, if possible. A series of messages will be displayed on the screen informing the user why the calibration failed and if the old values have been restored. See Section 6 *Maintenance*.

## 5.4 AUTO Calibration

The IR7000 has a built-in auto calibration routine. To use this feature, the user must install a solenoid valve on each of the calibration gas sources. Electrical connections for the solenoid valves are made on the rear panel at the Zero and Span Valve terminals. See Section 3 for installation instructions.

The calibration sequence is handled automatically but certain parameters must be set up for the feature to work properly.

**NOTE:** *It is necessary to perform a MANUAL CALIBRATION at least once prior to using the AUTO CALIBRATION feature for the first time. This is to establish an "appropriate" CAL DELAY period. The default value for CAL DELAY is known to be invalid for many applications. It, in all likelihood, is not the optimum value for your setup. You must run a MANUAL CALIBRATION to determine the proper delay period. See Section 4-2 for instructions in determining the optimum CAL DELAY value.*

- Enter an appropriate CAL DELAY in the SETUP/CALDELAY.

**NOTE:** *Without an appropriate CAL DELAY period, the calibration data will most likely be invalid since the sample cell would not have been properly purged.*

- Make sure that the proper concentration for the span gas being used has been entered into the SETUP/CALGAS submenu.
- If an O<sub>2</sub> channel is present, make sure that the concentration of the O<sub>2</sub> bearing span gas has been entered into the SETUP/O<sub>2</sub> CALGAS submenu.
- If periodic calibration is desired, enter the type of calibration (ZERO or FULL), and the number of hours between calibrations in the SETUP/CAL TIME submenu.

**NOTE:** *Setting the time to 0 turns the autocalibration feature off.*

- Set whether the display and output should TRACK the data while calibrating or HOLD the last value before the calibration. This is done in the MODE/CAL menu. See Section 4.3.

Choosing HOLD institutes a CAL DELAY before and after the ZERO and SPAN calibrations. This is to allow for adequate purging of the sample cell. At the end of the SPAN calibration, the instrument will send a signal to the span gas valve to close. If you select TRACK, make sure that you allow a period of time after calibration for the concentration to readjust as sample gas replaces the calibration gas in the cell. You can determine what is an “adequate” time by watching the display as it changes to reflect the dynamic conditions within the cell.

- The instrument is now set to automatically calibrate at the frequency entered into the CAL TIME submenu.

*NOTE: The priority in the timing chip is low for the CAL TIME feature. Thus the actual time between calibrations maybe different than the specified value in CAL TIME.*

## 5.5 Calibration Issues

- **Pressure or flow variation**

The detection process inherent in the patented dual chamber balance detector essentially involves a “counting” of the molecules of the gas of interest within the sample cell. Any pressure or flow variation changes the instantaneous number of gas molecules in the fixed volume cell and hence causes a span error proportional to the pressure variation.

- **Obtaining a valid difference between ZERO and SPAN**

The absolute count from a given concentration of the gas of interest will vary with time but the difference (delta) between the zero level and same level will remain essentially constant. Thus the need to get a valid difference between zero and span is crucial.

In principle, the detector will zero on almost any gas however, in practice a true zero gas such as dry nitrogen with minimum absorption in the IR spectrum is used. Using any other gas as a ZERO gas may cause calibration errors.

At the factory, during initial setup and calibration, a valid delta is established using dry nitrogen and an appropriate span gas for the application at hand. When the instrument is first

linearized at the factory, a maximum delta using a full span gas (100%) is determined and permanently burned into memory. This value is used to compare subsequent readings (real or calibration) to determine if:

- A) The reading is real and not an anomaly.
- B) In the case of a calibration, the calibration yielded valid data i.e. the delta obtained is within 30% of the maximum delta determined at the factory. If not, a calibration alarm message is displayed and the old calibration values are restored. See Section 5.4.

- **Drift**

During calibration, approximately 40 readings are taken in 20 seconds. The imbedded software looks at the difference of 39 pairs of successive readings i.e. reading #1 – reading #2, reading #2 – reading #3 etc., and analyzes these successive pairs in terms of their spread about 0. If the system is stable as it should be during calibration, then theoretically, these readings should all be 0 or close to it although there may be some spread about 0. If the number of pairs that are increasing are seriously out of balance with the number that are decreasing, the software generates an error depending on the nature of the imbalance. If the number of increasing values is much greater than the number of decreasing values, the software will assume that the system is drifting. It will immediately reset and attempt to recalibrate. There will be a maximum of 5 attempts at recalibration before an alarm condition is displayed and the system restores the old calibration values.

In this case, you may receive an “IR LOWFLOW FAIL” alarm. Most often, this is due to an insufficient purge of the sample cell prior to calibration. Increase the CAL DELAY time significantly and try again.

*NOTE: If an alarm condition is encountered, the alarm latches in the sense that the message will only go away when the condition is corrected AND the alarm is acknowledged. Correcting the conditions of the alarm only will NOT clear the alarm message. Acknowledging the alarm only will NOT clear the alarm. YOU MUST DO BOTH! To acknowledge any alarm, press the UP button on the front display.*

## Maintenance

---

The information in this section is to be used by qualified service trained personnel only. To avoid injury, do not perform any service or maintenance procedure described in this section unless you are properly trained.

### 6.1 Scheduled Maintenance

The IR7000 does not require any periodic maintenance beyond normal cleaning and filter replacement. In cases where the analysis is performed on a hazardous gas, a routine leak checking procedure should be adopted.

#### 6.1.1 Cleaning

To clean the exterior surface of the analyzer, use a mild solution of soap and water and apply with a dampened cloth. Do not use solvents. Do not spray or apply any liquid directly onto the case or front panel.

#### 6.1.2 Particle Filter

The sample path in some versions of the IR7000 is equipped with a disposable 0.3-micron particulate filter. This filter is not meant to be the primary sample filtering device. If the primary sample filter fails this filter may become clogged. This will increase the backpressure inside the system and reduce the flowrate. The filter should be checked periodically and replaced as necessary.

To replace the particulate filter:

**WARNING:** Depending on the sample system used, sample gas may be still flowing in the sample lines. Make sure that the sample gas is turned off before beginning this procedure.

- Flush the instrument lines with nitrogen for 15 minutes.
- Turn off the instrument and disconnect the power cord. It is recommended that you install a lock-out device so that the instrument cannot be powered back up unless the lock-out device is removed.

- Remove the screws securing the case and remove slide the case off the analyzer.

**WARNING:** Hazardous voltage exists inside. Make sure that the instrument is OFF and the AC power cord has been removed from the AC power source.

- Locate the particle filter (see Figure 6-1).

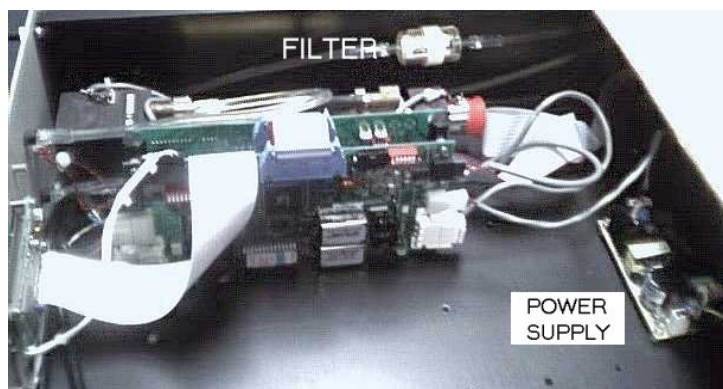

Figure 6-1: Particle Filter Location

**NOTE:** The filter must be installed in the proper orientation. There is an arrow on the filter indicating the direction of flow. Before removing the gas lines, identify the inlet and exit ends of the lines for proper reinstallation.

- Remove the PVC tubing from the ends of the filter while the filter is still attached to the frame.
- Loosen the holding clamp and remove the filter.

**WARNING:** Depending on your application, the filter may contain hazardous materials. Adhere to all local, state and federal regulations regarding the disposal of contaminated waste.



- Insert the replacement filter into the holding clamp noting the proper flow direction. Tighten the clamp to secure the filter to the frame.
- Reattach the tubing ends onto the filter.
- Replace the cover and secure it with the screws.
- Remove any lock-out devices, connect the power cord to the AC source and turn the instrument ON.

- Recalibrate the instrument (see Chapter 5). Check the gas flow through the analyzer. With a new filter, the flow will increase. Readjust the flow to 1.5–2.0 SCFH.

## 6.2 Service

The IR7000 is highly integrated and has very few user-serviceable areas. This section covers:

- Removal of the optical bench and components for cleaning
- Replacing the IR source
- Replacing the battery (portable model only)
- Replacing the fuse

### 6.2.1 Removing the Optical Bench (Non-Explosion Proof)

Removal of the optical bench is for cleaning the sample cell or replacing the IR source. For any other operation or repair, the analyzer must be sent to the factory with the optical bench intact.

*NOTE: Instruments with dual optical benches have 2 non-interchangeable sample cells. To avoid confusion service only one optical bench at a time.*

To remove the optical bench:

1. Turn off the sample gas flow

**WARNING:** Depending on the sample system used, sample gas may be still flowing in the sample lines. Make sure that the sample gas is turned off before beginning this procedure.



2. Flush the instrument lines with nitrogen for 15 minutes.
3. Turn off the instrument and disconnect the power cord. It is recommended that you install a lock-out device so that the instrument cannot be powered back up until the lock-out device is removed.
4. Loosen the screws securing the front panel and pull open the drawer containing the optical bench and electronics.



**WARNING:** Hazardous voltage exists inside. Make sure that the instrument is OFF and the AC power cord has been removed from the AC power source.

5. Identify the parts and location of the Optical Bench Assembly. See Figure 6-2.
- **Sample Cell** – This is a glass tube internally coated with gold or silver. It is installed in a front-to-back orientation in the analyzer. Instruments designed to measure trace levels use a longer sample cell which is oriented diagonally within the case. Instruments designed to measure high percentage levels employ a much smaller cell that directly connects the IR source and detector.

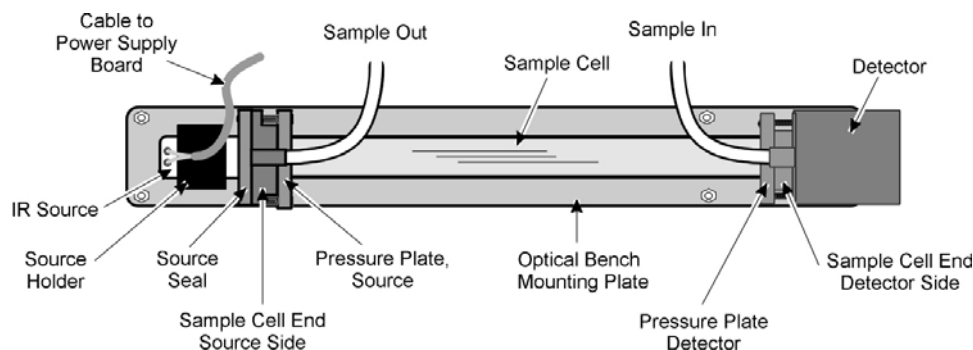

Figure 6-2: Optical Bench Components

- **Source Holder** – The source holder is the black mounting block on one end of the sample cell.
- **IR Source** – The IR source is the silver metal cylinder inserted into the source holder.
- **Detector** – The detector is the square block at the other end of the sample cell. It normally carries a label reading “Detector #XXXX” Where XXXX refers to the particular detector for that instrument only. The detector cannot be interchanged with other instrument.
- **Optical Bench Mounting Plate** – The long metal plate running under the sample cell, detector and source holder is the optical mounting plate. It is used to secure the optical bench components in proper alignment.
- **Couplers on Sample Cell** – There are 5 plastic parts and 4 O-rings that are used to couple the cell to the detector and source. From the detector end of the cell to the source they are:
  - Sample Cell End, Detector Side
  - Pressure Plate

- 2 O-Rings
- Pressure Plate, Source
- Sample Cell End, Source Side
- Source Seal
- 2 O-Rings

6. Remove the PVC tubing connected to the sample cell. The tubing is secured to the sample cell with plastic ties. Carefully cut the ties using diagonal cutters. PUSH the end of each piece of tubing off the fitting to disconnect the tubing.

**CAUTION:** Do not pull the tubing off the connectors. This could damage the sample cell or break the feed connector on the plastic coupler.



7. Disconnect the four cables that connect to the Optical Bench Assembly. Note the location of the connectors before disconnecting them.
- **Gray Cable** – connects between the detector and the main board at J10. On instruments with dual benches, note which main board is involved.
  - **Gray Cable** – connects between the IR Source and the main board at J2. On instruments with dual benches, note which main board is involved.
  - **Twisted Pair Cable** – There are 2 twisted pair cables connecting between the optical bench mounting plate and the main board. Disconnect the cables from the power supply board at J6 and J7. On instruments with dual benches, note which main board is involved.
8. Remove the 4 nuts and washers that secure the optical bench mounting plate to the case.
9. Remove the Optical Bench Assembly from the instrument.

**CAUTION:** Do not lift the assembly out by the sample cell! Lift the assembly out by grasping the source holder and the detector. Use care to avoid snagging the loose wires on any other component when lifting the assembly out of the case.



10. Loosen the 4 screws in the brown coupling between the detector and the sample cell but do not remove.

**NOTE:** *If the instrument is designed for high percentage analysis and no gold colored Sample cell is visible, then remove the 4 screws.*

11. Remove the 2 screws from the underside of the Optical Bench Mounting Plate that secure the IR source holder.
12. Separate the sample cell from the detector using a gentle pulling and twisting motion. The cell is held in place with 2 O-rings. Unless the coupling between the cell and detector is dismantled, the O-rings should not pull out with the sample cell.

During reassembly, make sure that the O-rings are not cut or damaged as the cell is inserted. Make sure that the cell reseats firmly within the O-rings.

**NOTE:** *If the instrument is designed for high percentage analysis and there is no gold colored Sample cell visible, then skip this step and go to Step # 14.*

13. Loosen but do not remove the 4 screws securing the coupling between the IR source and the sample cell.
14. Separate the sample cell from the IR source using a gentle pulling and twisting motion. The cell is held in place with 2 O-rings. The O-rings are held in pockets fabricated in the sample cell pressure plate. They should not pull out when removing the sample cell.

During reassembly, make sure that the O-rings are not cut or damaged as the cell is inserted. Make sure that the cell reseats firmly within the O-rings.

Reassemble the optical bench by the reversing the above steps. During reassembly, make sure that both the sample cell and IR source are fully seated in the connecting couplers.

**WARNING:** After servicing any part of the sample circuit, upon reassembly, a leak check of the sample cell and tubing is required.



### 6.2.2 Cleaning the Sample Cell

**WARNING:** The sample cell is a glass tube (Metal Optional) which can be broken if excessive force is applied to it. The fragments of a broken sample cell are sharp and can cause serious injury. Use caution when handling the cell.



1. Clean the Sample cell with soap and water followed by a final rinse in de-ionized or distilled water.
2. Prepare a final rinse solution comprised of:

70% isopropyl alcohol  
30% distilled water

3. Rinse the Sample cell with the above solution to remove any spots. A household glass cleaner can be used in place of the above solution however the resulting surface is not as clean.

**CAUTION:** Never use a brush or any other object to scrub the inside of the sample cell. The gold or silver coating is soft and can easily be scratched.



4. Allow the Sample cell to air dry.
5. Reinstall the Sample cell by reversing the steps in Section 6.2.1.

### 6.2.3 Replacing the IR Source

To replace the IR source, disassemble the optical bench and remove the sample cell as described in Section 6.2.1.

Cut the plastic tie that holds the gray cable from the IR source to the holder. If not done already, disconnect the other end of this cable from the main board J2. On instruments with dual benches, note which main board is involved.

With the IR source disconnected from the sample cell and the IR source holder free of the optical bench mounting plate, the IR source can be removed by loosening the small plastic hex set screw in the holder.

Insert the new source into the IR source holder and reassemble the sample cell as described in Section 6.2.1. Use a plastic tie to secure the source cable to the holder.

*NOTE:* With the Sample cell disassembled, it would be convenient to clean the cell as described in Section 6.2.2.

### 6.2.4 Replacing the Battery (Portable Model Only)

To replace the battery in the portable model:

1. Flush the instrument with nitrogen for 15 minutes.
2. Turn off the instrument and, if connected, remove the battery charger.
3. Disconnect the probe from the front of the instrument.
4. Remove the screws securing the top case and slide the case off the analyzer.

5. Disconnect the positive and negative wires from the battery.
6. Remove the 4 screws and the ground wire from the hold down plate across the battery. Remove the plate.
7. Exchange the battery with a new battery P/N 5215. Orient the battery so that the positive terminal is facing the front panel and toward the center of the instrument.

**CAUTION: Use only the factory approved replacement battery. Using any other battery could damage the instrument.**

8. Reinstall the hold down plate together with the ground wire.
9. Connect the positive and negative wires to the proper terminals.

**CAUTION: Make sure proper polarity is observed. Severe damage to the unit can occur if these terminals are reversed.**



10. Reassemble the cover and reattach the probe.

With the instrument on, check the display for a “BATTERY LOW” message. If this appears, charge the new battery for 1 hour before placing the instrument into service.

### 6.2.5 Changing the Fuse

If the instrument fails to power up and there is no display, check that AC power is available and the instrument OFF/ON switch is ON. On the portable model, make sure that the power is ON and that the battery is charged. If there is still no power check the fuse.

The fuse is located in the power entry module (inside the instrument case in the battery portable. See Figure 6-3.)

To change the fuse:

1. Flush the instrument with nitrogen for 15 minutes.
2. Turn off the instrument and remove the power cord from the power entry module ( if portable, remove the battery charger.)
3. Locate the fuse holder and pop out the fuse.
4. Replace with a 1A or 2A, 250V fuse.
5. Reconnect the AC power.
6. Turn the instrument ON.

*Figure 6-3: Fuse Location.*

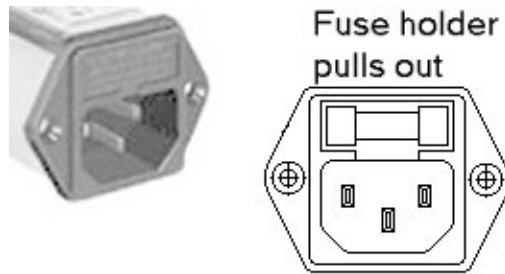

### 6.3 Display Messages

Various messages appear on the front panel display during operation. There are 3 categories of messages:

- Error Messages
- Normal Operation Messages
- Normal Operator-Induced Messages

The following sections describe the messages and where appropriate, suggest corrective action.

## 6.3.1 Error Messages

MESSAGE	DESCRIPTION	CORRECTIVE ACTION
NEED GOOD CALS	The battery backed ram memory has been lost.	Normal display will return after valid zero and upscale calibrations have been performed.
IR ZERO CAL FAIL [CAUSE] CALS RESTORED OR NEED GOOD CALS	A zero calibration was attempted and did not succeed. Cause of the failure will be displayed.	Insufficient cell purge. Increase CAL DELAY period or purge time. Check for proper zero gas. Check sample system for leaks.
IR UPSC CAL FAIL [CAUSE] OLD CALS RESTORED	A span calibration was attempted and did not succeed. Cause of the failure will be displayed.	Insufficient cell purge. Increase CAL DELAY period for AUTOMATIC calibrations or increase purge time for MANUAL calibrations. Check for proper span gas. Check sample system for leaks.
IR LOW FLOW FAIL	While a calibration was attempted, the signal from the detector drifted in one direction.	Insufficient cell purge. Increase CAL DELAY period for AUTOMATIC calibrations or increase purge time for MANUAL calibrations.
<i>NOTE: The IR LOW FLOW FAIL message will occur only after the instrument has made 5 attempts (50 seconds each) to capture a level value.</i>		
IR CAL SPAN FAIL	A calibration was attempted that did not produce a sufficient difference between zero and span gases.	Most frequently, this is caused by attempting a full calibration on the SAMPLE gas. <b>The instrument will zero calibrate on your sample gas if requested to do so!</b>
NEED GOOD CALS	No previous successful calibration data exists in memory. Old calibration data cannot be restored.	Check that the SETUP: CAL GAS value has been set to the labeled value on the tank of calibration gas. Memory backup battery is discharged. Replace.
IR CAL RESTORED	A calibration failed for one of the above reasons. The data from the most recent calibration is restored as the current value.	

<p>LINEARIZER ERROR</p>	<p>The linearizer software has failed in the self-diagnostic test while in use.</p>	<p>Press either UP or DOWN key to acknowledge the alarm and continue normal operation.</p> <p>If the message occurs again, turn the instrument off for 10 seconds then power back up.</p>
<p>LINEARIZER FAILURE</p>	<p>The linearizer software has failed during the power –up self-diagnostic test.</p>	<p>To clear the message, turn the instrument off for 10 seconds, then power back up.</p> <p>If the message re-occurs, discontinue use of the instrument and contact LSC.</p>
<p>CALVALUE CHANGED</p>	<p>The stored calibration readings have failed in the continuous self-test.</p>	<p>Press either UP or DOWN key to acknowledge the alarm and continue normal operation.</p> <p>If the message occurs again, turn the instrument off for 10 seconds then power back up.</p> <p>If the message re-occurs, discontinue use of the instrument and contact LSC.</p>
<p>NO EPROM PRESENT</p>	<p>Some portion of the permanent memory is not available to the microprocessor.</p>	<p>Turn the instrument off for 10 seconds, then power back up.</p> <p>If the message re-occurs, discontinue use of the instrument and contact LSC.</p>
<p>EXTERNAL RAM FAILURE</p>	<p>Some portion of the addressable memory is failing initialization self-test.</p>	<p>Turn the instrument off for 10 seconds, then power back up.</p> <p>If the message re-occurs, discontinue use of the instrument and contact LSC.</p>
<p>NO DATA READY FAILURE</p>	<p>A hardware fault has been detected in the main board.</p>	<p>To clear the message, turn the instrument off for 10 seconds, then power back up.</p> <p>If the message re-occurs, discontinue use of the instrument and contact LSC.</p>
<p>O2 SENSOR FAIL</p>	<p>The digitized oxygen sensor is significantly out of range.</p>	<p>Replace the O<sub>2</sub> sensor.</p> <p>If the message re-occurs, discontinue use of the instrument and contact LSC.</p>
<p>O2 ZERO FAIL [CAUSE] OXYCALS RESTORED NEED GOOD CALS</p>	<p>An O<sub>2</sub> zero calibration was attempted and did not succeed.</p>	<p>Insufficient cell purge. Increase CAL DELAY period or purge time.</p> <p>Check for proper zero gas.</p> <p>Check sample system for leaks.</p>

<p>O2 UPSC FAIL [CAUSE] OXYCALS RESTORED NEED GOOD CALS</p>	<p>An O<sub>2</sub> span calibration was attempted and did not succeed.</p>	<p>Most frequently, this is caused by attempting a full calibration on the SAMPLE gas. <b>The instrument will zero calibrate on your sample gas if requested to do so!</b></p> <p>Check SETUP: O2 CAL GAS for proper O<sub>2</sub> span gas value.</p> <p>Impending O<sub>2</sub> sensor failure. Replace the O<sub>2</sub> sensor.</p> <p>Check sample system for leaks.</p>
<p>???</p>	<p>If ??? appears in place of any operator selected function, it indicates that the stored value is not within the expected range.</p>	<p>Re-enter the correct value. If the error is not caused by a hardware fault, attempting to change the value will bring it back within the normal range.</p>
<p>IR UNDER RANGE</p>	<p>The measured value is more than 1% of full scale negative.</p>	<p>Recalibrate the instrument.</p> <p>If recalibration does not correct this error, discontinue using the instrument and contact LSC.</p>
<p>IR OVER RANGE</p>	<p>The measured value is more than 120% of the rated full scale of the instrument.</p>	<p>Recalibrate the instrument.</p> <p>If recalibration does not correct this error, discontinue using the instrument and contact LSC.</p>
<p>O2 UNDER RANGE</p>	<p>The measured oxygen value is more than 1% of full scale negative.</p>	<p>Recalibrate the instrument.</p> <p>Replace the O<sub>2</sub> sensor.</p> <p>If the error occurs again, discontinue use of the instrument and contact LSC.</p>
<p>O2 OVER RANGE</p>	<p>The measured oxygen value is more than the rated full scale of the oxygen channel.</p>	<p>Recalibrate the instrument.</p> <p>Replace the O<sub>2</sub> sensor.</p> <p>If the error occurs again, discontinue use of the instrument and contact LSC.</p>
<p>O2=*FAILED CAL*</p>	<p>A calibration failed for one of the above reasons and there is no valid data from a previous successful calibration.</p>	
<p>O2 =*SENSOR FAIL*</p>	<p>The digitized oxygen sensor signal is significantly out of range.</p>	<p>Replace the O<sub>2</sub> sensor.</p> <p>If the error occurs again, discontinue use of the instrument and contact LSC.</p>

**6.3.2 Normal Operation Messages**

MESSAGE	DESCRIPTION
IR ALARM LOW	The measured value is below the low alarm setpoint. The LOW ALARM condition exists.
IR ALARM HIGH	The measured value is above the high alarm setpoint. The HIGH ALARM condition exists.
PATENT PENDING VERSION VXXX	One of the startup screens. Indicates the software version (XXX) installed.
FIRST POWER UP DEFAULTS	Startup screen indicating status of battery backed memory. If memory has been corrupted or lost, all user settable values are set to default values.
BATTERY BACKUP RECOVERY	During power-up, indicates that the battery-backed memory is good.
FULL CAL REMOTE CALIBRATION	The instrument is performing a full zero and span calibration which was requested through the optional opto-isolated digital input.
FULL CAL AUTO CALIBRATION	The instrument is performing a full zero and span calibration which was initiated by the passing of the number of hours set in SETUP: CAL TIME.
NEG DRIFT ZERO CALIBRATION	An automatic zero calibration is in progress because the measurement was more than 2% of instrument span in a negative direction and automatic calibration is enabled.
DOING ZERO CALIBRATION	A zero calibration is in progress.
DOING UPSC CALIBRATION	A span calibration is in progress.
LOCKED	The instrument is being controlled through the opto-isolated digital input or RS-232 option. This action locks out the front panel until a code is sent to unlock the panel. See Section A-3.
NONLIN	Indicates the instrument is operating in nonlinear mode.
COUNT	Indicates the instrument is operating in raw sensor signal mode and is not displaying concentration..
RETRY	Indicates that the instrument rejected the data captured while attempting a calibration. It is extending the calibration in an attempt to capture valid data.
BATTERY LOW	The battery installed in the portable model is nearly discharged.

	<p>Either the battery should be discharged or the instrument turned off until charging is possible.</p> <p>Continued operation in BATTERY LOW mode will cause the CHARGE BATT mode listed below.</p>
CHARGE BATT	<p>The battery in the portable model is discharged.</p> <p>The instrument does not function as an analyzer while in this mode.</p> <p>The instrument should be turned off and the battery charged before further operation.</p> <p>Failure to turn off the instrument while in CHARGE BATT mode can shorten the life of the battery.</p>

### 6.3.3 Normal Operator Induced Messages

MESSAGE	DESCRIPTION
DOING MANUAL ZERO CALIBRATION	A manual zero calibration has been requested. The instrument is currently performing the calibration.
DOING MANUAL SPAN CALIBRATION	A manual span calibration has been requested. The instrument is currently performing the calibration.
?ARE YOU SURE?   KEEP   LOSE	<p>Prompts for saving information into one of the SETUP submenus.</p> <p>Pressing the UP key will store the changed number.</p> <p>Pressing the DOWN key or allowing the 60-second timer to expire will discard the changes and restore the previous value.</p>
[KEPT] SETPOINT CHANGE	Confirmation that a change made in one of the SETUP submenus was stored.
!LOST! SETPOINT CHANGE	Indicates that a change entered into one of the SETUP submenus was not saved. The previous value was restored.
SETUP: CALGAS	Screen from the SETUP menu. It indicates the entered value for the concentration of the span gas.
SETUP: CALTIME	<p>Screen from the SETUP menu. It indicates the period between automatic calibrations.</p> <p>Change the period using the front panel UP and DOWN keys.</p> <p>A value of 0 turns the AUTO calibration feature OFF.</p>

SETUP: CAL DELAY	<p>Screen from the SETUP menu. It indicates the time specified for delaying the onset of a calibration. This delay is generally used for purging the cell before calibrating.</p> <p>Delay time can be changed using the front panel UP and DOWN keys.</p>
SETUP: = CHART X	<p>Screen from the SETUP menu. It displays the current value of full scale for the indicated range (x = 1–4).</p> <p>Use the UP and DOWN keys to change the full scale value for that output range.</p>
SETUP: = ALARM L	<p>Screen from the SETUP menu. It displays the current setpoint for the LOW alarm.</p> <p>Use the UP and DOWN keys to change the setpoint.</p>
SETUP: = ALARM H	<p>Screen from the SETUP menu. It displays the current setpoint for the HIGH alarm.</p> <p>Use the UP and DOWN keys to change the setpoint.</p>
SETUP: 02 CAL GAS	<p>Screen from the SETUP menu. It indicates the entered value for the concentration of the oxygen span gas.</p> <p>Value can be changed using the UP and DOWN keys in the front panel.</p>
MODE: CALIBRATE?	<p>Screen from the MODE menu. It allows the user to initiate a manual calibration – zero, span or both.</p>
MODE: CHART = X	<p>Screen from the MODE menu. Allows the user to select an output range or enable the autorange feature.</p>
MODE: FILTER = X	<p>Screen from the MODE menu. Used to select the amount of filtering applied to the measurement. See Section 2.3.3.</p>
MODE: CAL = HOLD/TRACK	<p>Screen from the MODE menu. Allows the user to select whether the instrument TRACKs the concentration during a calibration or HOLDS the last value before calibration began.</p>
MODE: LINEAR/NONLINEAR	<p>Screen from the MODE menu. Selects whether data is linearized, nonlinearized, or displayed as a raw signal from the detector.</p>
MODE: BRIGHT = X	<p>Screen from the MODE menu. Alters the display brightness.</p>
MODE: AUTO = ZERO/FULL	<p>Screen from the MODE menu. Used to determine the type of auto calibration.</p>

*NOTE: In an instrument with a dual optical bench, this menu will appear in the primary display (left display). This menu is not applicable to the portable model.*

MODE: ALARM =  
ON/OFF

Screen from the MODE menu. Allows the operator to toggle the audible alarm on or off.  
If the alarm is sounding, pressing either the UP or DOWN key will acknowledge the alarm and silence it.

---

## Appendix

---

### A-1 Specifications

<b>Measuring Method:</b>	NDIR single beam Electrochemical cell for oxygen
<b>Display:</b>	Vacuum fluorescent, 2 lines 16 characters
<b>Alarms:</b>	High and Low Limit, user settable
<b>Analog Output:</b>	0–1V, 0–5V, or 0–10V full scale. Optional 4–20 mA isolated or non-isolated
<b>Ranges:</b>	4 user defined, selectable autorange
<b>Power Source:</b>	120/240 VAC 50/60 Hz Portable model includes rechargeable battery and battery charger.
<b>Max. Power Consumption:</b>	110 VAC — 2 amps 230 VAC — 1 amp
<b>Power Consumption:</b>	50 Watts/channel
<b>Sample Cell:</b>	Glass (Metal Optional), gold, buna-n, Lexan, epoxy, sapphire, 304 stainless steel
<b>Sample Temperature:</b>	-10° to +50°C (14°–122°F)
<b>Sample Flow:</b>	Rack mounted: 0.1–2 lpm (0.2–4 scfh) Trace gas: 5.0–10 lpm (10–20 scfh) Portable: 1 lpm (2 scfh) internal sample pump
<b>Sample Condition:</b>	Non-condensing, particulate free
<b>Operating Conditions:</b>	-10° to +50°C (14°–122°F)
<b>Storage Conditions:</b>	-10° to +80°C (14°–176°F) 0° to +50°C (14°–122°F) oxygen cell
<b>Warm-up Time:</b>	3 hours optimum, usable in 1 hr.

**Dimensions:**

Rack mounted: 22.5”L x 17.1”W x 5.25”H  
(571mm L x 447mm W x 133mm H)  
Portable: 20.0”L x 8.5”W x 5.25”H  
(508mm L x 216mm W x 133mm H)  
Wall mounted: 24.0”L x 20.0”W x 6.0”D  
(609mm L x 508mm W x 152mm D)

**Weight:**

Rack mounted: 38 lbs (17.2 kg)  
Portable: 19 lbs (8.6 kg)  
Wall mounted: 43 lbs (19.5 kg)

**Resolution:** 0.1% of f.s. (Trace: 0.1 ppm)  
2% of f.s. for oxygen cell

**Repeatability:**  $\pm 0.1\%$  of f.s. (Trace:  $\pm 0.5\%$  of f.s.)

**Noise:**  $\pm 0.1\%$  of f.s. (Trace:  $\pm 0.5\%$  of f.s.)

**Drift:**  $\pm 0.3\%$  of f.s. determined on max.range  
absolute for all other ranges.  
Trace:  $\pm 1.0\%$  of f.s. determined on  
max.range. Absolute for all other ranges.

**Response Time (T90):** User selectable 15–60 seconds typically  
for nominal flow rates

**A-2 Recommended Spare Parts List**

<b>Qty</b>	<b>P/N</b>	<b>Description</b>
2	5117	Sample Filter
2	5296	Fuse

*Note: Orders for replacement parts should include the part number (if available) and the model and serial number of the instrument for which the parts are intended.*

Orders should be sent to:

**Teledyne Analytical Instruments**

**16830 Chestnut St.**

**City of Industry, Ca. 91748**

**Phones: (626) 961-9221, (626) 934-1500**

**Fax: (626) 961-2538**

**Email: sales@IR7000.com**

### A-3 RS-232 Communication Protocol

- The RS-232 serial communication option allows back and forth communication between the IR7000 and a remote PC. The features of the IR7000 can be controlled and interrogated through the serial port. It will output data in response to a variety of requests.
- There is a standard format for requests and commands sent to the IR7000 and sent back from the instrument.

Each separate command or data packet is transmitted as an ASCII string enclosed by a start and stop character.

"(" is the ASCII start character — "STX"

")" is the ASCII stop character — "ETX"

- All messages begin with the start character "(" followed by a 3-character code. This code defines what the subject of the message is. Any data that is required by the message is inserted after the code and followed by the stop character ")". In many messages, the code is the complete message and will be followed by the stop character.

For example, a typical message exchange would be:

FROM user TO IR7000:     **(e1C)**

"(" is the start character.

e1C is the code requesting the set value of the span calibration gas.

")" is the stop character.

FROM IR7000 TO user:     **(e1C00100+)**

")" is the stop character.

e1C is the code stating that this is the set value of the span calibration gas.

00100+ is the numerical value, with sign

")" is the stop character.

- The serial port operates in half-duplex mode, either sending or receiving data at any time. Sending information to the instrument while it is still replying to a previous message will disrupt the message.

- The code section of any message is always 3 characters in length. The codes are case sensitive. They must be sent exactly as follows:

The first character is lower case

The second and third are upper case

- If the decimal value (eDV) for the instrument is -1, then the numeric value for the gas concentration is multiplied by 10 in the instrument display.

For example:

(e1L) returns (e1L00500+ ) and the display reads +5000.

- There are 5 types of code. Each type starts with a type identifier character followed by 2 characters that select the specific message within that type. The 5 types of code are: "e", "s", "c", "m", and "a".

- **"e" type codes:**

Messages containing "e" type codes cause the instrument to reply (emit) with information that was requested by the code. It does not change the operation of the instrument.

Example: From user: **(eAE)**

Back from instrument: (eAE enabled)

- **"s" type codes:**

Messages containing "s" type codes cause the instrument to change a setpoint to the value sent with the code.

If a setpoint code is properly executed, the return message will be the code as interpreted by the instrument.

These setpoints are normally changed through the buttons on the instrument's front panel. To prevent a conflict between the front panel entry and the serial port entry, the code which locks the front panel must be sent before a type "s" code will be obeyed. The panel unlocking code should be sent when finished so normal operation of the front panel will resume.

If setpoint codes are sent without locking the panel, a message inside the start/stop characters will be returned with the original 3 character code followed by the text string "**need\_panel\_lock**".

If a setpoint code containing an inappropriate value is sent, one of several error codes will be returned.

All setpoints are stored in 16 bit registers so all setpoint values must be less than 65,000 and must be positive.

Including a setpoint value in excess of 65,000 will return an error message inside the start/stop characters with the original 3 character code followed by the text string "**beyond\_16\_bits**".

Attempting to pass a negative setpoint will return an error message inside the start/stop characters with the original 3 character code followed by the text string "**no\_minus\_numbers**".

Sending a setpoint code that is not followed by a number returns an error message inside the start/stop characters with the original 3 character code followed by the text string "**bad\_number**".

Sending a setpoint code that is outside the valid setpoint range returns an error message containing the original 3 character code followed by the text string "**range\_error**" inside the start/stop characters.

- **"c" type codes:**

Messages containing "c" type codes command a MODE change identical to those entered on the front panel using the MODE button.

If an unknown code is sent following the "c", the reply will be "**c??**".

If an illegal value is sent following a valid mode, the reply will be the mode followed by "**?not\_match**".

- **"m" type codes:**

Messages containing "m" type codes retrieve non-alarm messages from the buffer that stores all event messages currently being displayed in succession on the front panel.

For example: the code (eGM) instructs the instrument to Gather Messages. This code returns the number of messages gathered.

**sent:** (mGM)      **returned:** (mGM00001+)

- **"a" type codes:**

Messages containing "a" type codes retrieve alarm messages from the buffer that stores the alarm messages that are currently valid.

Example: the code (eGA) instructs the instrument to Gather Alarm. This code returns the number of alarms gathered.

**sent:** (aGA)      **returned:** (aGA00002+)

Two alarms have been retrieved.

Example: the code (aEA) instructs the instrument to Emit Alarm . This code returns a 2 digit alarm number with 16-character message text.

**sent:** (aEA)      **returned:** (aEA1.5[ir\_under\_range])

### A-3.1 Codes for "e" Type Messages

The codes for "e" type messages are:

CODE	MESSAGE	RETURN
AE	<u>A</u> udible alarm <u>E</u> nabled?	"enabled" or "disabled"
AH	<u>A</u> larm <u>H</u> igh limit triggered?	"alarm" or "ok"
AL	<u>A</u> larm <u>L</u> ow limit triggered?	"alarm" or "ok"
AP	<u>A</u> uto cal <u>P</u> eriod in hours?	<number>
AS	<u>A</u> udible alarm <u>S</u> ounding?	"alarm" or "ok"
CD	<u>C</u> al <u>D</u> elay?	<number>
CS	what <u>C</u> al <u>S</u> elected? (in progress)	"none" or "zero" or "upscale"
CT	<u>C</u> al <u>T</u> rack or hold?	"track" or "hold"
DB	<u>D</u> isplay <u>B</u> rightness	"0" or "1" or "2" or "3"
DV	<u>D</u> ecimal <u>V</u> alue (position of dp)	<number>
FS	<u>F</u> ilter <u>S</u> election?	<number>
LM	<u>L</u> inear <u>M</u> ode?	"linear" or "nonlin" or "counts"
PL	<u>P</u> anel <u>L</u> ocked	"locked" or "unlock"
RS	chart <u>R</u> ange <u>S</u> elected?	"a" or "1" or "2" or "3" or "4"
RU	chart <u>R</u> ange in <u>U</u> se?	"1" or "2" or "3" or "4"
TC	<u>T</u> imed <u>C</u> al type?	"zero" or "full"
XG	<u>o</u> Xygen <u>C</u> al good?	"ok" or "no_zero" or "no_ups" or "no_both"
1L	<u>1</u> <sup>st</sup> (ir) <u>L</u> ow alarm setting?	<number>
1C	<u>1</u> <sup>st</sup> (ir) <u>C</u> al gas value	<number>
1G	<u>1</u> <sup>st</sup> (ir) cal <u>G</u> ood	"ok" or "no_zero" or "no_ups" or "no_both"
1I	<u>1</u> <sup>st</sup> (ir) displayed value?	<number>
1N	<u>1</u> <sup>st</sup> (ir) <u>N</u> ame of gas?	"name" ("CO=")
1R	<u>1</u> <sup>st</sup> (ir) chart <u>R</u> ange <u>1</u> value?	<number>
2R	chart <u>R</u> ange <u>2</u> value?	<number>
3R	chart <u>R</u> ange <u>3</u> value?	<number>
4R	chart <u>R</u> ange <u>4</u> value?	<number>
1S	<u>1</u> <sup>st</sup> (ir) <u>S</u> ensor raw counts	<number>
1U	<u>1</u> <sup>st</sup> (ir) <u>U</u> nits of displayed value?	"name" ("PPM")
1X	<u>1</u> <sup>st</sup> <u>o</u> Xygen span cal setting?	<number>
1P	<u>1</u> <sup>st</sup> (ir) <u>o</u> Xygen value in Percent?	<number>
1D	<u>D</u> ecimal value oxygen	<number>
1H	<u>1</u> <sup>st</sup> (ir) <u>H</u> igh limit alarm setting	<number>

**A-3.2 Codes for "s" Type Messages**

The codes for "s" type messages are:

CODE	RETURN MESSAGE
1C	<u>1</u> <sup>st</sup> (ir) <u>C</u> al gas value
AP	<u>A</u> uto cal <u>P</u> eriod in hours
1R	chart <u>R</u> ange <u>1</u> value
2R	chart <u>R</u> ange <u>2</u> value
3R	chart <u>R</u> ange <u>3</u> value
4R	chart <u>R</u> ange <u>4</u> value
1H	Setpoint 2 trigger level
1L	Setpoint 1 trigger level
CD	<u>C</u> al <u>D</u> elay
1X	<u>1</u> <sup>st</sup> o <u>X</u> ygen span cal setting

**A-3.3 Codes for "c" Type Messages**

The codes for "c" type messages are:

CODE	MODE NAME	VALUE
PL	<u>P</u> anel <u>L</u> ock	1 = lock, 0 = unlock
DB	<u>D</u> isplay <u>B</u> rightness	0 thru 3 (3 is brightest)
RS	chart <u>R</u> ange <u>S</u> elected	0 = Autorange, 1 thru 4
FS	<u>F</u> ilter <u>S</u> elected	0 = filter 1    1 = filter 10 2 = filter 100    3 = filter 1000
CT	<u>C</u> al <u>T</u> rack/hold	1 = track    0 = hold
TC	<u>T</u> imed <u>C</u> al type	0 = full    1 = Zero only
AE	audible <u>A</u> larm <u>E</u> nable	0 = disabled    1 = enabled
LM	<u>L</u> inear <u>M</u> ode	0 = linear    1 = nonlinear    2 = counts
CS	<u>C</u> al <u>S</u> elect	0 = Zero    1 = Span    2 = both
AK	<u>A</u> larm ac <u>K</u> nowledge	1 = acknowledge alarm

### A-3.4 Codes for “m” Type Messages

The codes for "m" type messages are:

CODE	MESSAGE	RETURN
GM	<u>G</u> ather <u>M</u> essage	# of messages gathered
EM	<u>E</u> mit a <u>M</u> essage	one message returned
DM	<u>D</u> efine <u>M</u> essage	message # returns text

### A-3.5 Codes for “a” Type Messages

The codes for "a" type messages are:

CODE	MESSAGE	RETURN
GA	<u>G</u> ather <u>A</u> larm	# of alarms gathered
EA	<u>E</u> mit <u>A</u> larm	one of the alarms gathered
DA	<u>D</u> efine <u>A</u> larm	with alarm #, returns alarm text