

# TELEDYNE ANALYTICAL INSTRUMENTS

## OPERATING & INSTRUCTION MANUAL

### Model 9060 Zirconia Oxygen Analyser

9060/2006

# CONTENTS

1. SPECIFICATIONS
2. DESCRIPTION
3. INSTALLATION & COMMISSIONING
4. OPERATORS FUNCTIONS - ALARMS
5. SETTING UP THE TRANSMITTER
6. MAINTENANCE

## APPENDICES

1. CONSTITUENT VALUES FOR VARIOUS FUELS
2. PROBE OR SENSOR EMF TABLES
3. LOG OXYGEN SCALE
4. SAMPLE LOG PRINT OUT
5. CIRCUIT SCHEMATIC
6. MODBUS™ REGISTER MAP  
DECLARATION OF CONFORMITY (LAST PAGE)

**Note: This manual includes software modifications up to Version 2.25, October 2005**

© Copyright TELEDYNE ANALYTICAL INSTRUMENTS - 1996 - 2006

Neither the whole nor any part of the information contained in, or the product described in, this manual may be adapted or reproduced in any material form except with the prior written approval of Teledyne Analytical Instruments (Teledyne Analytical Instruments).

The product described in this manual and products for use with it, are subject to continuous developments and improvement. All information of a technical nature and particulars of the product and its use (including the information in this manual) are given by Teledyne Analytical Instruments in good faith. However, it is acknowledged that there may be errors or omissions in this manual. A list of details of any amendments or revisions to this manual can be obtained upon request from Teledyne Analytical Instruments Technical Enquires. Teledyne Analytical Instruments welcome comments and suggestions relating to the product and this manual.

***All correspondence should be addressed to:***

### **Technical Enquires**

Teledyne Analytical Instruments  
16830 Chestnut Street  
City of Industry Phone: 626 934 1500  
CA 91748  
USA Fax: 626 961 2538

All maintenance and service on the product should be carried out by Teledyne Analytical Instruments' authorised dealers. Teledyne Analytical Instruments can accept no liability whatsoever for any loss or damage caused by service or maintenance by unauthorised personnel. This manual is intended only to assist the reader in the use of the product, and therefore Teledyne Analytical Instruments shall not be liable for any loss or damage whatsoever arising from the use of any information or particulars in, or any error or omission in, this manual, or any incorrect use of the product.

# USING THIS MANUAL

The Teledyne 9060 Oxygen Transmitter has a variety of user-selectable functions.

They are simple to use because each selection is menu driven. For options you are not sure about; read the manual on that particular item.

Please read the safety information below and the 'Installation' section before connecting power to the transmitter.

## CAUTION 1

The probe or sensor heater is supplied with mains voltage. This supply has electrical shock danger to maintenance personnel. Always isolate the transmitter before working with the probe or sensor, gas solenoids, or the transmitter.

The EARTH wire (green) from a heated probe or sensor must ALWAYS be connected to earth.

## CAUTION 2

Combustion or atmosphere control systems can be dangerous. Burners must be mechanically set up so that in the worst case of equipment failure, the system cannot generate explosive atmospheres. This danger is normally avoided with flue gas trim systems by adjustment so that in the case of failure the appliance will not generate CO in excess of 400 ppm in the flue. The CO level in the flue should be measured with a separate CO instrument, normally an infrared or cell type.

## CAUTION 3

The oxygen sensor which is heated to over 700°C (1300°F) and is a source of ignition. Since raw fuel leaks can occur during burner shutdown, the transmitter has an interlocking relay that removes power from the probe or sensor heater when the main fuel shut-off valve power is off. If this configuration does not suit or if it is possible for raw fuel to come into contact with a hot oxygen probe or sensor then the Model 9060 Analyser with a heated probe or sensor will not be safe in your application.

An unheated probe can be utilised in such applications, however the oxygen readings are valid only above 650°C (1200°F).

## CAUTION 4

The reducing oxygen signal from the transmitter and the associated alarm relay can be used as an explosive warning or trip. This measurement assumes complete combustion. If incomplete combustion is possible then this signal will read less reducing and should not be used as an alarm or trip. A true excess combustibles transmitter, normally incorporating a catalyst or thermal conductivity bridge, would be more appropriate where incomplete combustion is possible.

Also read the probe or sensor electrical shock caution in Section 2.5 and the probe or sensor heater interlock caution in Section 3.6.

## CAUTION 5

If an external pressure transducer is used to feed the process pressure to the transmitter for pressure compensation, it is essential that the pressure transducer is accurate and reliable. An incorrect reading of pressure will result in an incorrect reading of oxygen. It is therefore possible that an explosive level of fuel could be calculated in the transmitter as a safe mixture.

## CAUTION 6

FIL-3 filter. If the optional FIL-3 has been fitted to the 1231 probe in this installation, please read the Important Notice in section 1.2.

# SPECIFICATIONS

# 1

- 1.1 MODEL 9060 OXYGEN ANALYSER FOR TWO OXYGEN SENSORS
- 1.2 SERIES 1230 OXYGEN PROBES AND SENSORS
- 1.3 PURGE & CALIBRATION CHECK ACCESSORIES
- 1.4 FILTER PURGE SWITCH

## 9060-Zirconia Analyser

### 1.1 MODEL 9060 OXYGEN ANALYSER FOR TWO OXYGEN PROBES

#### DESCRIPTION

The Teledyne Model 9060 oxygen analyser/ transmitter provides in-situ measurement for two oxygen probes in furnaces, kilns and boilers and flue gases with temperatures from ambient up to 1400°C (2550°F). The transmitter provides local indication of oxygen plus thirteen other selectable variables.

One or two probes or sensors in one process can be controlled from one transmitter providing an average and/or individual sensor signals. Two linearised and isolated 4 to 20 mA output signals are provided. Alarms are displayed at the transmitter and relay contacts activate remote alarm devices. The transmitter, which is available for heated or unheated zirconia oxygen probes, provides automatic on-line gas calibration check of the probe and filter purging. The electronics self-calibrates all inputs every minute.

The 9060 has a keyboard for selecting the output range, thermocouple type, etc., as well as maintenance and commissioning functions. The instrument is microprocessor based and all adjustments are made using the keyboard.

- **Used for air / fuel ratio combustion control to provide fuel savings**
- **Used for product quality control in ceramic and metal processing industries**
- **Simple to install**
- **Linear output of % oxygen for recording or control**
- **Built in safety features**
- **26 different alarm conditions that warn the operator of combustion, probe, or transmitter problems**
- **Isolated RS 232-C printer/computer interface and an RS 485 MODBUS network interface**
- **Safety interlock relay for heated probes**

# 9060-Zirconia Analyser

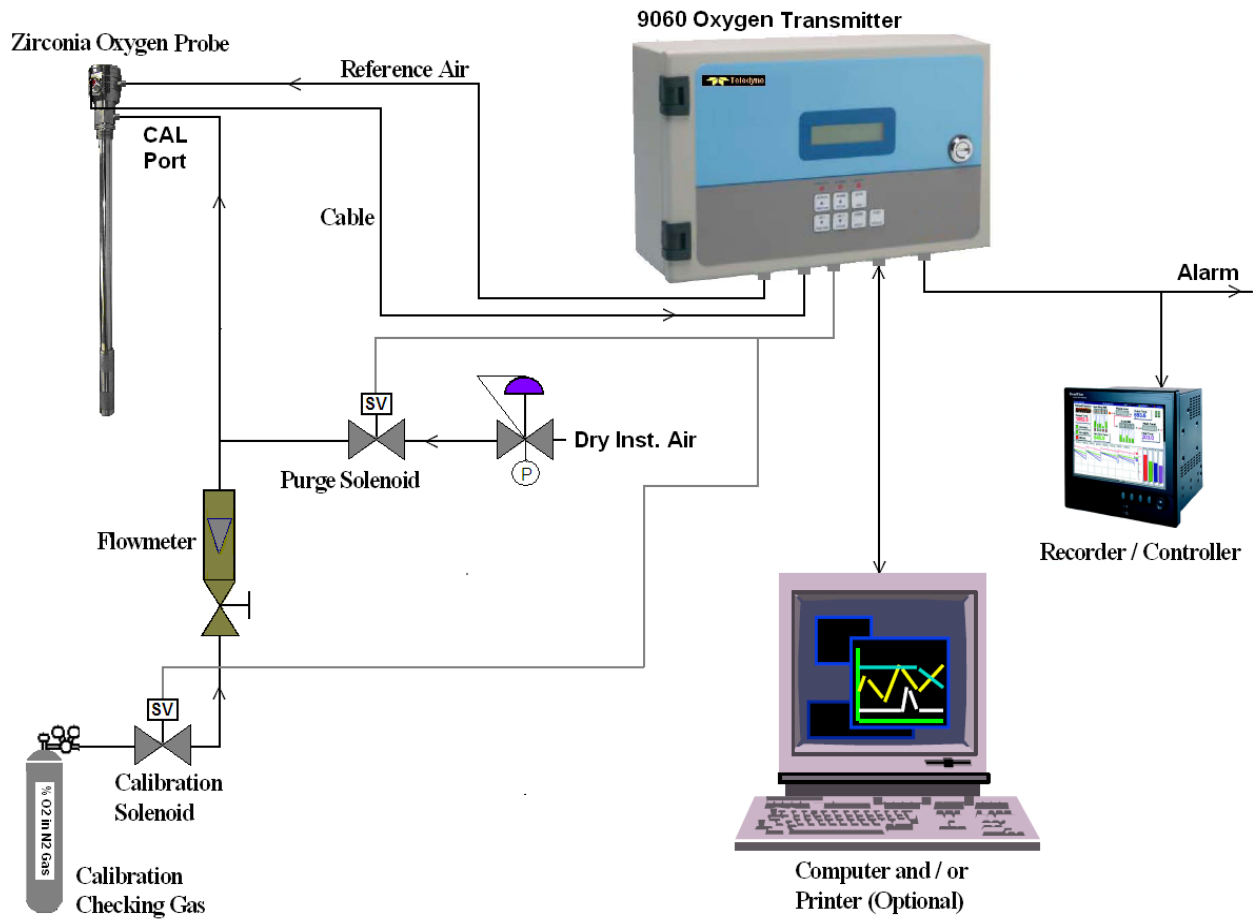

## Oxygen Probe and Transmitter System

## SPECIFICATIONS

### Inputs

- Zirconia oxygen probe, heated or unheated
- Furnace, kiln or flue thermocouple, field selectable as type K or R.
- Main flame established safety interlock (for heated probes only)
- Purge pressure switch
- Dual Fuel selector
- Remote alarm accept

### Outputs

- Two linearised 4 to 20 mA DC outputs, max. load 1000Ω
- Common alarm relay
- Three other alarm relays with selectable functions

### Computer

- RS 232-C or RS 485 for connection of a computer terminal or printer for diagnostics of the transmitter, probe, sensor or combustion process. This connection is suitable for network connection to computers, DCSs or PLCs using MODBUS protocol.

### Range of Output 1

#### Field selectable from the following:

<i>Output Selection</i>	<i>Range</i>
Linear, Probe 1	0 to 1% oxygen to 0 to 100 % oxygen
Linear, Probe 1 and 2 averaged (If 2 probes are used)	0 to 1% oxygen to 0 to 100 % oxygen
Log	0.1 to 20 % oxygen, fixed
Reducing	100 % to 10 <sup>-4</sup> oxygen, fixed
Reducing	10 <sup>-1</sup> to 10 <sup>-25</sup> % oxygen, fixed
Linear, probe 1, very low range	0 to 0.001% to 0 to 2.0 % oxygen (10ppm to 20,000ppm)

### Range of Output 2

#### Field selectable from the following:

<i>Output</i>	<i>Zero Range</i>	<i>Span Range</i>
Sensor EMF	0 to 1100 mV in 100 mV steps	1000 to 1300 mV in 100 mV steps
Carbon Dioxide	0 to 10 %	2 to 20 %
Oxygen Deficiency	0 to 20% O <sub>2</sub> deficiency	0 to 100% O <sub>2</sub> excess
Aux Temperature	0 to 100°C (32 to 210°F) in 1 degree steps	100 to 1400°C (210 to 2550°F) in 100 degree steps
Log Oxygen	0.1% O <sub>2</sub> Fixed	20% O <sub>2</sub> Fixed
Reducing Oxygen	10 <sup>+2</sup> (100%) to 10 <sup>-10</sup> % oxygen in one decade steps, non-overlapping	10 <sup>-3</sup> to 10 <sup>-30</sup> % oxygen in one decade steps. Min span two decades.
Linear Oxygen, probe 2	0% oxygen, fixed	1 to 100%
Combustibles %, Probe 1	0% combustibles fixed	0.5 to 2.0 %
Linear, Probe 1 and 2 averaged (If 2 probes are used)	0% oxygen, fixed	1 to 100%

### Range of Indication, Upper Line

- Auto ranging from  $10^{-30}$  to 100% O<sub>2</sub>

### Indication Choice, Lower Line

Any or all of the following can be selected for lower line display:

- Date - time
- Run Hours since last service
- Date of last service
- Probe 1 oxygen
- Probe 2 oxygen
- Probe 1 EMF
- Probe 2 EMF
- Probe 1 Temperature
- Auxiliary Temperature
- Probe 2 Temperature
- Probe 1 Impedance
- Probe 2 Impedance
- Ambient Temperature
- Ambient Relative Humidity
- Carbon Dioxide
- Combustibles
- Oxygen Deficiency

The oxygen deficiency output can be used in the same way as a combustibles transmitter to signal the extent of reducing conditions of combustion processes.

### Accuracy

- $\pm 1\%$  of actual measured oxygen value with a repeatability of  $\pm 0.5\%$  of measured value.

### Relay Contacts

- 0.5A 24 VAC, 1A 36 VDC

### Environmental Rating

- Operating Temperature: -25 to 55°C (-15 to 130°F)
- Relative Humidity: 5 to 95% (non-condensing)
- Vibration: 10 to 150Hz (2g peak)

### Power Requirements

- 240 or 110V, 50/60 Hz, 105 VA (heated probe)
- 240 or 110V, 50/60 Hz, 5 VA (unheated probe)

### Weight

- Transmitter, 3.75 kg (10 lbs.)

### Dimensions

- 280mm (11") W x 180mm (7") H x 95mm (3.75") D

### Degree of Protection

- IP65 without reference air pump
- IP54 with reference air pump

### Mounting

- Suitable for wall or surface mounting.

### 1.2 SERIES 1230 OXYGEN PROBES & SENSORS

#### DESCRIPTION

Teledyne series 1230 oxygen probes and sensors employ state-of-the-art zirconia sensors and advanced materials, which provide the following benefits:

- Improved control due to fast response time to typically less than four seconds
- Cost-efficient design provides improved reliability
- Longer-life probes with greater resistance to corrosion from sulphur and zinc contaminants in flue gas
- Low cost allows maintenance by replacement
- Reduced probe breakage due to greater resistance to thermal shock and mechanical damage during installation and start-up

Series 1230 probe or sensors are simple to install and maintain. All models provide direct measurement of oxygen level. On-line automatic calibration check is available if required. Probes or sensors may be used with Teledyne oxygen transmitters and some model transmitters from other manufacturers. See Set-up 5.5.90 for more details.

All Novatech oxygen probe or sensors are designed and manufactured to exacting standards of performance and reliability. Series 1230 probe or sensors are the result of extensive research and development by Novatech, industry and government agencies. Teledyne Analytical Instruments provides application and after sales support for oxygen probes, sensors and transmitters, worldwide.

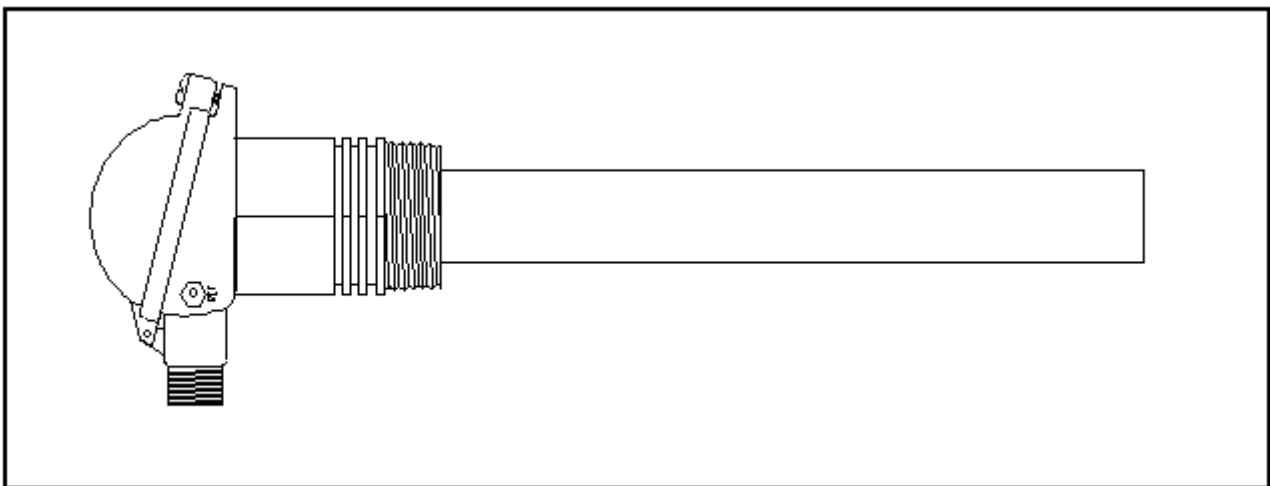

**Model 1231 Heated Oxygen Probe**

## 9060-Zirconia Analyser

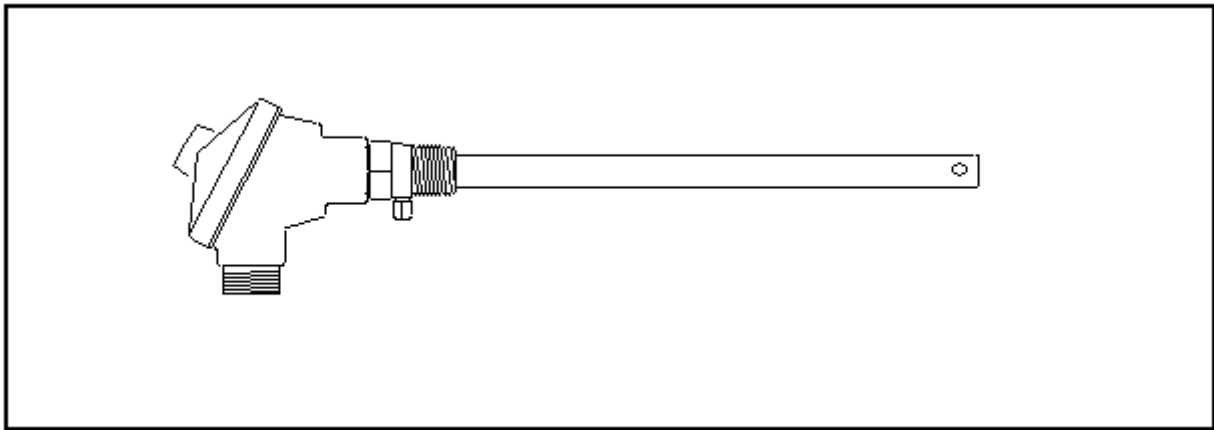

**Model 1232 Unheated Oxygen Probe**

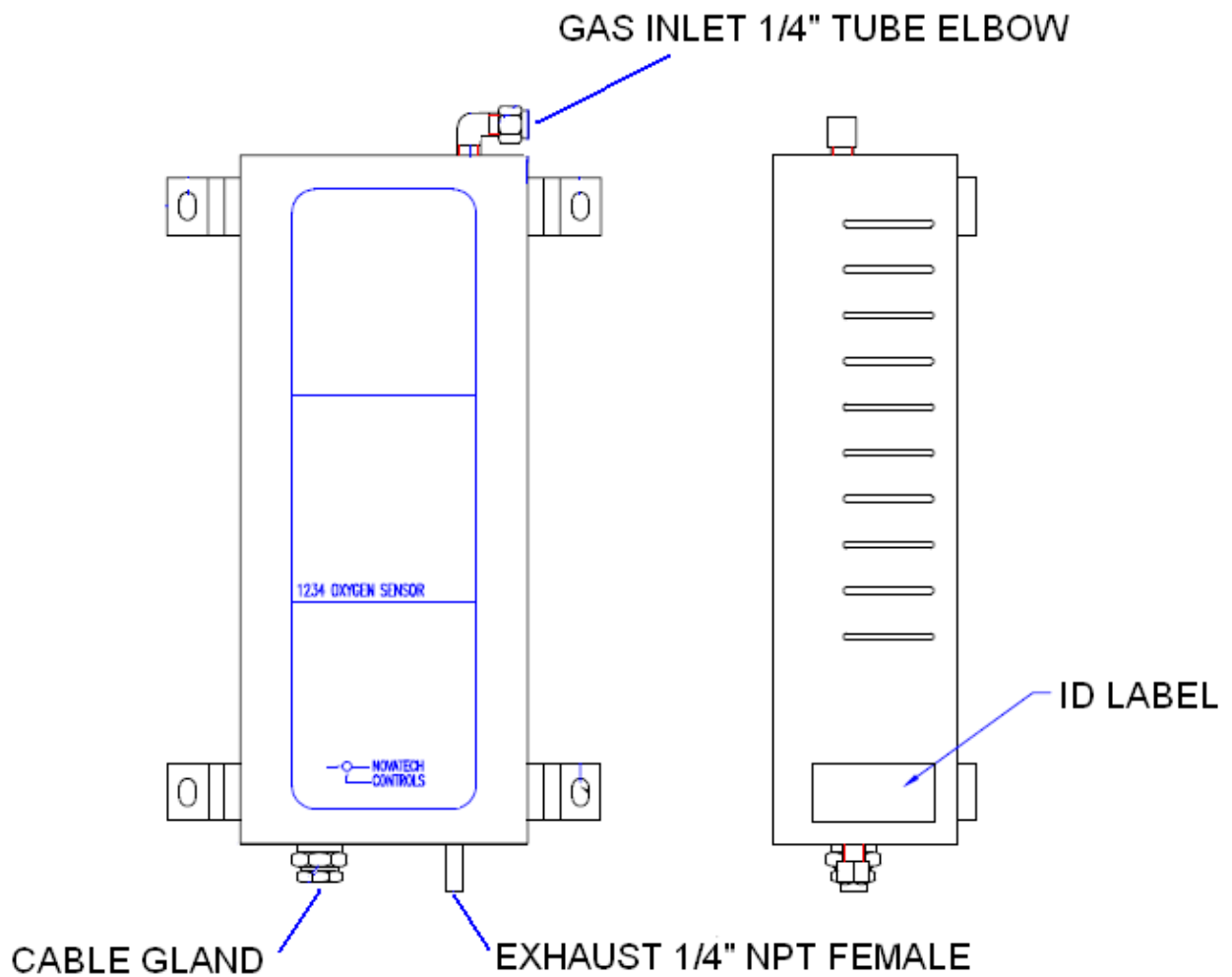

### STANDARD PROBE 'U' LENGTHS

#### 1231

250 mm (10")  
350 mm (14")  
500 mm (20")  
750 mm (30")  
1000 mm (40")  
1500 mm (60")  
2000 mm (80")

#### 1232

500 mm (20")  
750 mm (30")  
1000 mm (40")  
1500 mm (60")

### Ordering Information

1. Probe insertion length (from process end of mounting thread to probe sensing tip).
2. Mounting thread (process connection), BSP or NPT (for size of thread refer to specifications).
3. Lagging extension length, if required.
4. If model 1232 probe, state preferred thermocouple type (refer to specifications).

### **Important Notice Regarding 1231 Probe Option - FIL-3**

**WARNING:** The only identifiable standard for flame arresters for general use is British Standard BS EN 12874:2001. British Standard BS EN 12874:2001 refers to an operating environment up to 150 Degrees Centigrade.

The FIL-3 device optionally fitted to 1231 Heated Zirconia Probes (the "Probes" or "Probe") operate in an environment considerably greater than 150 Degrees Centigrade.

Therefore, we know of no Australian, British, European or USA standard applicable to flame arresters or their testing above 150 degrees Centigrade. Consequently, the FIL-3 device cannot be certified as a safety device.

The probe is only one of several potential sources of ignition. Extreme care is required when using the probes during the start up processes of a combustion appliance.

The Teledyne Burner Interlock Relay facility, which is a standard part of the Teledyne transmitter, is designed to be wired to the main safety shut-off fuel valves in a way that can shutdown the probe heater when the fuel valves are closed.

The risk of ignition of flammable gas mixture at the hot end of the Probe can only be minimised by correct use, maintenance and operation of the FIL-3 device. The user of the FIL-3 device is responsible for verification and maintenance and correct use and operation of the FIL-3 device.

THE USER AGREES THAT IT USES THE PROBE AND THE FIL-3 DEVICE AT ITS SOLE RISK. TELEDYNE ANALYTICAL INSTRUMENTS, TO THE FULL EXTENT PERMITTED BY LAW, GIVES NO WARRANTIES OR ASSURANCES AND EXCLUDES ALL LIABILITY (INCLUDING LIABILITY FOR NEGLIGENCE) IN RELATION TO THE PROBE AND THE FIL-3 DEVICE.

The user must ensure that it correctly follows all instructions in relation to the Probe and FIL-3 device, correctly understands the specifications of the Probe and FIL-3 device and ensures that the Probe and FIL-3 device are regularly inspected and maintained.

FIL-3 equipped Probes should be inspected at least once a year for corrosion and more frequently if there is any reason to suspect that corrosion may have occurred.

## OXYGEN PROBE SPECIFICATIONS

MODEL	1231	1232
<b>Application</b>	Combustion flue gases below 900°C (1650°F) Refer to note 1	Combustion flue gases above 700°C (1290°F) with no contaminants. eg. natural gas, light oils
<b>Temp. Range</b>	0 to 900°C. Refer to note 2 (32 to 1650°F)	700 to 1400°C (1470 to 2550°F)
<b>Length</b>	250 to 2000 mm (10" to 80")	500 to 1500 mm (20" to 60")
<b>Process Connection</b>	1 ½" BSP or NPT	¾" BSP or NPT
<b>Electrical Connection</b>	Weatherproof plug-in connector or optional screw terminals. The plug connector can be supplied with the cable.	
<b>Cable</b>	Order a specific length with the transmitter	
<b>Heater</b>	Yes	No
<b>Thermocouple</b>	K, integral	R, integral
<b>Response Time</b>	Typically < 4 secs.	Typically < 1 sec
<b>Head Temperature</b>	-25 to 100°C (-15 to 210°F) with weatherproof connector -25 to 150°C (-15 to 300°F) with screw terminals	
<b>Reference Gas</b>	Ambient air 50 to 150 cc/min (3 to 9 scim). Pump can be supplied with transmitter	
<b>Ref Air Connection</b>	1/4" NPT	Integral air line in probe cable. Barbed fitting to 3/16" ID PVC tube.
<b>Filter</b>	Removable sintered titanium alloy particulate filter, 30 micron standard, optional 15 micron available. Refer to note 2	
<b>CAL Check Gas Connection</b>	1/8" NPT female	1/8" NPT female
<b>Weight</b>	2 kg (4.4 lb) plus 165 g (5.8 oz) / 100 mm (4") length	1 kg (2.2 lb) plus 100 g (3.5 oz) / 100 mm (4") length

## 9060-Zirconia Analyser

### Notes:

1. Care must be taken to avoid contact with explosive or inflammable gases with 1231 heated probes and 1234 oxygen sensors when hot. Teledyne transmitters have built in safety protection.
2. Process gas temperature must be below 800°C if the filters are fitted.
3. Please contact factory for corrosives other than sulphur or zinc. We can provide test materials to try in your atmosphere.

## OXYGEN PROBE MODEL SELECTION GUIDE

### Heated probes-temperature range 0-900°C (1650°F).

1231	U Length	Outer Sheath	Internal Thermocouple	Mounting Thread
Basic model	2. 250mm (10") 3. 500mm (20") 4. 750mm (30") 5. 1000mm (40") 6. 1500mm (60") 7. 2000mm (80")	1. 316 SS max 850°C (1560°F) 2. Inconel *(1)	1. Type K max 900°C (1650°F)	1. 1 ½ BSP 2. 1 ½ NPT

\*Note: (1) The Inconel option has all inconel wetted parts except for the ceramic sensor and viton 'o' rings.

### Unheated probes for clean gases-temperature range 700-1400°C (1290-2550°F).

1232	U Length	Outer Sheath	Internal Thermocouple	Mounting Thread
Basic model	3. 500mm (20") 4. 750mm (30") 5. 1000mm (40") 6. 1500mm (60")	1. 253 MA-max 1000°C (1830°F) 3. High Purity Alumina max 1300°C (2370°F) Horizontal max 1400°C (2550°F) Vertical 4. 446 SS max 1000°C (1830°F)	1. Nil *(2) 4. Type R max 1400°C (2550°F)	1. 3/4" BSP fixed 2. 3/4" NPT fixed

\*Note: (2) A standard oxygen probe for carburising furnaces, has a 253 MA sheath.

## 1234 SENSOR SPECIFICATIONS

Range of measurement:	1 ppm to 100% oxygen
Output:	EMF = $2.154 \cdot 10^{-2} \cdot T \cdot \log_e(0.209/\text{oxygen level of the sample})$
Accuracy:	± 1%
Thermocouple:	Type K
Heater:	110 VAC 50 / 60Hz, 100 watts
Heater proportional band:	80°C (175°F)
Speed of Response:	Less than 100 milliseconds
Sample flow rate:	1 to 5 litres / minute (120 to 600 scfm)
Differential Pressure:	80 to 800 mm (3 to 30") WG gives a flow of 1 to 5 litres / min (120 to 600 scfm)
Process Connections:	1/4" NPT female, inlet and outlet
Dimensions:	300 mm (11.81") high by 125 mm (4.92") wide by 88 mm (3.46") deep
Weight:	2.1 kg (4.6 lb)

### 1.3 PURGE & CALIBRATION CHECK ACCESSORIES

Due to the absolute measurement characteristics of zirconia sensors and the self-calibration features of Teledyne transmitters, probe calibration checks with calibrated gas are not normally required. In some installations however, automatic gas calibration checks are required by Environmental Protection Authorities and by engineering management in Power Stations, Oil Refineries and similar large end users.

Teledyne probes and transmitters provide a ready method of connecting on-line calibration check gases. They provide on-line automatic checking of probe and transmitter calibration, as well as a probe purge facility.

The absolute characteristics of zirconia sensors require only one calibration check gas to properly check the probe's performance. Where required however, the dual gas calibration check facility can be utilised.

Dirty flue gas applications often require the back purge facility to keep a probe filter free from blockage. (In these applications, it is more reliable to install probes pointing vertically downwards with no filter). Purge and calibration check solenoid valves can be operated manually or automatically from a 9060 Analyser.

The external components required for automatic / manual gas calibration checking are:

- A calibration check gas flow meter/regulator
- A mains voltage (240 or 110 VAC) solenoid valve for each calibration check gas

The external components required for automatic / manual purging are:

- A mains voltage (240 or 110 VAC) purge solenoid valve
- A purge pressure switch, 0 to 35 kPa (0 to 5 psi), to test for filter blockage.

The user should supply:

- Span gas cylinder(s), typically 2 % oxygen in nitrogen or a similar percentage of O<sub>2</sub> close to the normal level in the gas stream being measured, to ensure fast recovery.
- A 100 kPa (15 psi) clean and dry instrument air supply when filter purging is required.

### 1.4 FILTER PURGE PRESSURE SWITCH

To automatically sense a blocked probe filter, a pressure sensor should be connected to the 'purge' line to the probe 'cal' port. It should be adjusted so that it energises just above the purge pressure with a new or clean filter installed. The switch contacts should be connected to terminals 12 & 13 (PURGE FL SWITCH).

If the filter is still blocked or partly blocked after an auto purge cycle, the pressure switch will energise and cause a 'Probe Filter Blocked' alarm. The contacts must be normally closed.

The pressure switch should have an adjustable range of 0 to 100 kPa (0 to 15 psi).

# DESCRIPTION

## 2

### SECTION NUMBER

- 2.1 THE ZIRCONIA SENSOR
- 2.2 THE OXYGEN PROBE OR SENSOR
- 2.3 THE TRANSMITTER
- 2.4 ALARMS
- 2.5 HEATER
- 2.6 APPLICATIONS WHERE SENSING POINT IS NOT AT ATMOSPHERIC PRESSURE
- 2.7 SENSOR IMPEDANCE
- 2.8 AUTO CALIBRATION—ELECTRONICS
- 2.9 MANUAL CALIBRATION—PROBES
- 2.10 AUTO CALIBRATION CHECKING—PROBES
- 2.11 AUTO PURGE
- 2.12 RS 485 NETWORK (MODBUS™) AND 232-C PORT
- 2.13 AUXILIARY TEMPERATURE THERMOCOUPLE
- 2.14 WATCHDOG TIMER
- 2.15 BACK UP BATTERY

## DESCRIPTION

### 2.1 THE ZIRCONIA SENSOR

The transmitter input is provided for a solid electrolyte oxygen probe, which contains a zirconia element and thermocouple. The probe is designed to be inserted into a boiler or furnace exit gas flue or similar process. A 1234 sensor is designed to be installed outside of the flue or process. Sampling lines and filters are not required for in-situ probes but they are required for 1234 sensors. When a sampling line is required, the sample flows to the sensor under process pressure in most applications. In applications where the process pressure is negative or neutral, a suction pump will be required. A reference air pump is provided in the 9060 oxygen Analyser. The internal construction of a probe or sensor is shown as follows.

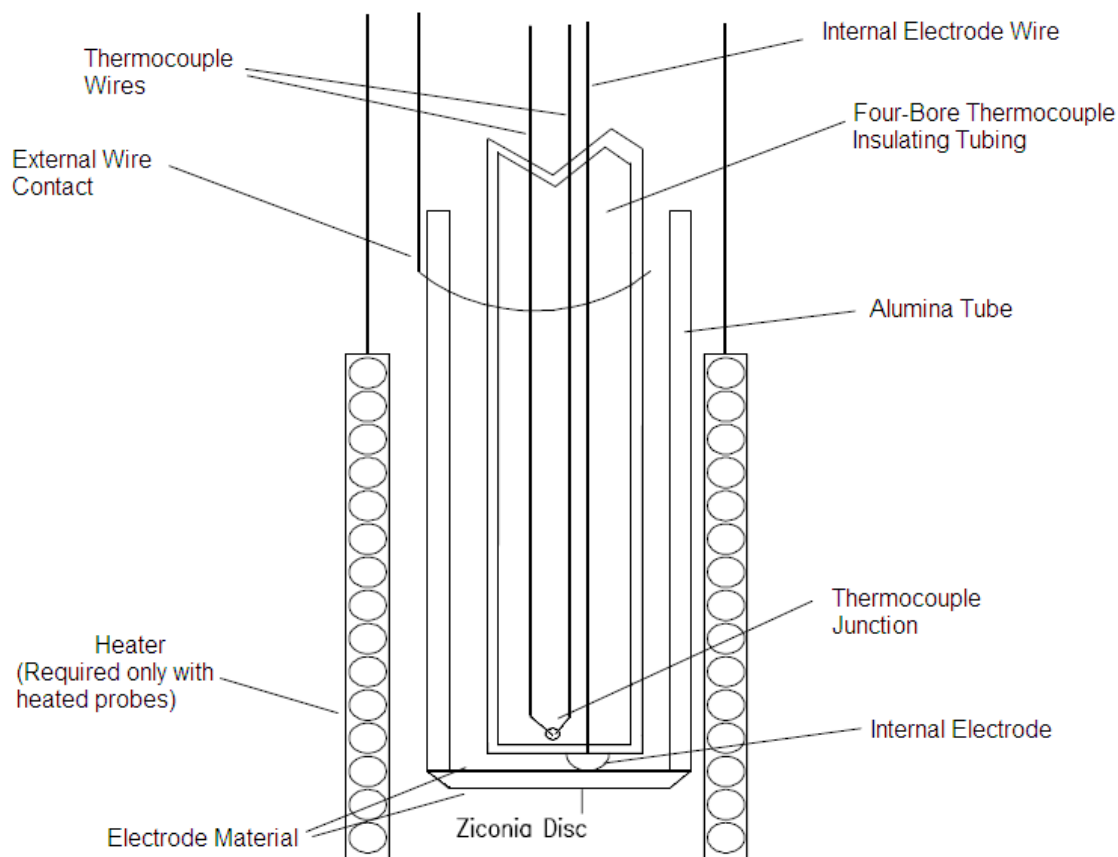

**Schematic View of a Zirconia Sensor Assembly**

The heater control in the 9060 Analyser consists of a time proportioning temperature controller and solid state relay so that the thermocouple junction is controlled to over 700°C (1300°F). Probes operating in a combustion environment above 650°C (1200°F) do not require a heater. When exposed to different oxygen partial pressures at the outside and inside of the sensor, an EMF (E) is developed which obeys the Nernst equation:

$$E \text{ (millivolts)} = \frac{RT}{4F} \log_e \left( \frac{(PO_2) \text{ INSIDE}}{(PO_2) \text{ OUTSIDE}} \right)$$

Where T is the temperature (K) at the disc (>650°C (1200°F)), R is the gas constant, F is the Faraday constant and (PO<sub>2</sub>) INSIDE and (PO<sub>2</sub>) OUTSIDE are the oxygen partial

## 9060-Zirconia Analyser

pressures at the inner and outer electrodes, respectively, with the higher oxygen partial pressure electrode being positive.

If dry air at atmospheric pressure, (21 % oxygen) is used as a reference gas at the inner electrode, the following equations are obtained:

$$E \text{ (millivolts)} = 2.154 \times 10^{-2} T \log_e \frac{0.21}{(\text{PO}_2) \text{ OUTSIDE}}$$

Transposing this equation

$$(\% \text{O}_2) \text{ OUTSIDE (ATM)} = 0.21 \text{ EXP } \frac{-46.421E}{T}$$

The 9060 Analyser solves this equation which is valid above 650°C (1200°F). The probe heater, or the process maintains the sensor temperature at this level.

### 2.2 THE OXYGEN PROBE OR SENSOR

The probe assembly provides a means of exposing the zirconia sensor to the atmosphere to be measured with sensor, thermocouple and heater wires connected via the transmitter lead. Reference air is fed via the plug for unheated probes and via a separate gas thread connection for heated probes.

Connections are provided on probes for an in-situ gas calibration check. A cleaning purge of air can be admitted via the calibration gas check entry. The outer sheath of probes can be metal or ceramic, depending on the application. Calibration check can be achieved on 1234 sensors using a three way solenoid which blocks the sample and at the same time admits a calibration check gas to the sensor. Purging a probe for any dust build up can be achieved in the same way.

In-situ zirconia oxygen probes will give a lower oxygen reading than a sampled gas measurement on a chromatograph or paramagnetic transmitter because the flue gas contains a significant level of water vapour and a sampling system removes the water vapour through condensation. The oxygen content then appears as a higher percentage of the remaining gas. For example: If the gas contained five parts oxygen and fifteen parts moisture, removing the moisture would leave the oxygen at 5.88%. This phenomena will depend on the fuel and the completeness of combustion. They are common to all in-situ oxygen sensors.

### 2.3 THE ANALYSER

The top line of the transmitter display will read oxygen in either % or ppm. The 9060 Analyser is a transmitter with two 4 to 20 mA outputs. One output is linear oxygen with selectable span. The second output can be selected as oxygen deficiency, combustibles, auxiliary temperature, reducing oxygen, percent carbon dioxide, sensor EMF or a logarithmic oxygen range. Four alarm relays are provided. Refer to the sections 4.2 and 4.3 for more details.

The 9060 Analyser is designed to operate with either one or two heated or unheated, zirconia probes or sensors in one process. If two sensors are being used, the transmitter can average the two oxygen signals, alarm when there is a high difference, transmit and display the average and/or individual oxygen signals.

## 9060-Zirconia Analyser

If heated probes are being used, the transmitter will maintain the temperature of the sensor(s) to over 700°C (1300°F). If the flue gas temperature is above 850°C (1560°F), the probe heater will cut out completely and the process will provide probe heating. The transmitter solves the Nernst equation and will provide accurate oxygen measurements up to 1500°C (2730°F), although most probes are suitable only to 1400°C (2550°F). 1231 heated probes are limited to 900°C (1650°F).

### 2.4 ALARMS

Refer to OPERATOR FUNCTIONS Section 4 for details on alarm functions.

### 2.5 HEATER

#### CAUTION

The probe or sensor heater is supplied with mains voltage. This supply has electrical shock danger to maintenance personnel. Always isolate the transmitter before working with the probe or sensor. The EARTH wire (green) from the probe/sensor must **always** be connected to earth.

The heater is supplied from the mains power directly, and the temperature is controlled initially at over 700°C (1300°F) after turn on.

### 2.6 APPLICATIONS WHERE SENSING POINT IS NOT AT ATMOSPHERIC PRESSURE

To apply the 9060 Analyser to processes that have pressure at the point of measurement significantly above or below atmospheric pressure, then compensation must be applied. (Refer to Set-up Steps 37 and 38 in Section 5.5). If two probes are being used, they must be close to the same pressure.

If the process pressure is not constant, it can be measured by a pressure transducer and fed into the oxygen transmitter as a 4-20mA signal. The pressure compensation will then change the oxygen reading according to the current process pressure.

### 2.7 SENSOR IMPEDANCE

The zirconia sensor impedance is a basic measurement of the reliability of the oxygen reading. A probe or sensor with a high impedance reading will eventually produce erroneous signals. The transmitter checks the zirconia sensor impedance every 24 hours and if the impedance is above the maximum level for a specific temperature then the impedance alarm (Sensor Fail) will be activated. Typical sensor impedance is 1 KΩ to 8 KΩ at 720°C (1320°F).

The impedance measurement can be updated manually whenever the sensor is over 700°C (1290°F) by pressing the "AUTO CAL" button while in "RUN" mode. The "Z" will appear in the top RH corner of the display for 3 seconds to confirm the measurement.

### 2.8 AUTO CALIBRATION - ELECTRONICS

The transmitter input section is self-calibrating. There are no adjustments. The analog to digital converter input stages are checked against a precision reference source and calibrated once every three seconds. Should the input electronics drift slightly then the drift will be automatically compensated for within the microprocessor. If the calibration

## 9060-Zirconia Analyser

factors are found to be have been changed more than expected, an 'ADC Warning' alarm is generated. If a large error occurs due to an electronic fault then an 'ADC CAL FAIL' alarm will occur.

A one-off calibration procedure of the precision reference sources should never need to be repeated for the instrument life unless the instrument has been repaired. For a description of the calibration procedure, refer to 'Setting Up The transmitter' Section 5.5, items 7, 8 9 and 10.

The digital to analog converters or output section of the transmitter are tested for accuracy when the 'AUTOCAL' button is pressed, and when the transmitter goes through the start up procedure. If the output calibration factors are found to have changed more than expected, the 'DAC Warning' alarm will occur. If either output has a fault, the 'DAC CAL FAIL' alarm will occur. The D/A sections are re-calibrated by pressing the 'AUTO CAL' button on the keyboard while in 'SET-UP' mode. Each of the output channels have three menu items which provide manual calibration (set-up 13 to 18). If manual is selected in set-up 13 or 16, the 'AUTO CAL' will be skipped and the manual calibration factors will be retained. See section 5.5 set-up 13, and section 6.3 for more details.

All output signals will drop to 0 mA for one-second period. It is suggested that a D/A re-calibration be performed after the instrument has stabilised, approximately 30 minutes after first switching on and after Setting Up The transmitter Section 5.5, items 6, 7, 8 and 9 have been completed, and then annually.

### 2.9 MANUAL CALIBRATION - PROBES

Calibration of the probe generally only requires the Sensor Offset to be set. See Section 5.5.11 for more details. If the offset for a sensor is not set the error will generally be less than 5% of the actual oxygen reading. By setting the offset the error will be less than 1% of the oxygen actual reading.

If a probe made by a manufacturer other than Teledyne Controls is used on the Teledyne transmitter, and/or improved accuracy is required at process levels of oxygen (well away from 20.9%) the "Low Oxygen Calibration" trim factors can be entered. (See also Section 5.5.90)

To manually set the "Low Oxygen Calibration" first set the Sensor Offset, then the "Low Oxygen Calibration".

1. To check a probe offset on site, the probe must be sensing air, with reference air, and allowed to settle at the probe operating temperature for 30 minutes. Read the offset in 'RUN' mode in millivolts on the lower line. Offset errors can occur if the sensor does not have some air passing over it. A gentle flow (<0.5 l/min) of air in the calibration check port can be provided by a reference air pump or similar. The best results will be obtained if the probe is removed from the process. For heated probes, if the combustion appliance is not operational and the probe heater is interlocked with the 'BURNER ON' signal, the 'BURNER BYPASS' switch should be set to 'ON to power the probe heater after removing the probe from the flue.

### CAUTION DANGER

Return the 'BURNER BYPASS' switch to normal (off) before installing the probe in the flue.

For unheated probes, the probe sensing tip must be raised to at least 650°C (1200°F) with a portable furnace.

Determine the probe offset in 'RUN' mode. Select 'Sensor EMF' on the lower line. With probe in air, stabilised at temperature for 30 minutes, read the 'Sensor EMF'. Switch back to 'set-up' mode and enter 'Sensor Offset' of equal value and the same polarity.

eg. If the measured 'SENSOR OFFSET' was -1.2 mV, enter -1.2 mV.

When reading the EMF offset, the flue pressure compensation must be set. If the probe has been removed from the flue, set the flue pressure compensation set up to "Fixed" in set-up 34, and the value to 0 in set-up step 38.

2. To set the probe "Low Oxygen Calibration", replace the air purge in the calibration check port with a flow of gas from a certified gas bottle. A flow of <1 l/min should be used. After purging for 1 minute compare the oxygen reading to the oxygen concentration on the bottle certificate. If the transmitter is reading lower than the certified level, switch to the 'set-up' mode and raise the figure set-up 90 (for sensor 1). An increase of 1% in the set-up entry will increase the oxygen reading by about 3% of the actual oxygen reading.

**NOTE:** If the set-up items 90 and 91 are not available, see section 5.1.

It is very unusual to need to change the settings by more than 1%. If a setting of more than 1% seems necessary, check for gas leaks, reference air flow or excess calibration gas flow.

### 2.10 AUTO CALIBRATION CHECKING - PROBES

On-line automatic gas calibration check is not normally required. Where it is required however, the probe can be checked for accuracy in-situ and on-line. Solenoid valves can admit up to two calibrated gas mixtures into the probe via solenoid valves under microprocessor control on a timed basis. For details on installation refer Section 3.11. For details on setting up this facility refer to Set-up steps 57 to 69 in Section 5.5.

During probe auto calibration checking, the transmitter output will freeze and remain frozen for a further adjustable period, allowing the probe time to recover and continue reading the flue gas oxygen level.

Calibration check gases may be manually admitted by pressing the 'CAL' buttons on the keyboard while in 'RUN' mode. The transmitter output is frozen during the pressing of these buttons and immediately becomes active when the button is released. If calibration gas checking is enabled in the Set-up menu for either gas, an automatic gas cycle can be started by pressing the 'CAL' buttons in RUN mode. Pressing any other button can terminate the cycle.

### 2.11 AUTO PURGE

In oil and coal fired plants, it is possible for the probe sensing filter to become blocked. An automatic purge cycle can be set up so that a blast of air, maximum 100 kPa (14.5 psi), will automatically back-flush the probe filter on a timed basis. Refer to Set-up steps 52 to 56 in Section 5.5. A purge pressure switch will sense if there is insufficient flow to clear the filter during the purge cycle. In this case a 'PROBE FILTER' alarm will occur. The probe can be manually purged from the keyboard while in 'RUN' mode. The transmitter output is not frozen during or after the pressing of this button.

If two probes are being used, the two probes could be driven by a common solenoid but separate pressure regulators and pressure switches (See section 3.11)

### 2.12 RS 485 NETWORK (MODBUS™) AND RS 232C PORT

The serial port has two functions. -

- It can be configured to connect up to 31 transmitters together on a MODBUS™ RS485 network. Each individual transmitter can be interrogated by a computer or PLC. The values of oxygen, sensor EMF, sensor temperature, sensor impedance for both oxygen sensors (if two sensors are being used on one transmitter) can be read over the network. The alarms status can also be checked over the network. For the connection details, see Section 3.15 and Appendix 6.
- It can be used to log the transmitter readings by connecting the transmitter to a printer, a data logger, or any computer using an RS232-C com port. When it is to be used to log the transmitter readings, use set-up step 82 to selected the items to be sent to the data logger. The log period may be selected in set-up step 83, and the baud rate may be set in set-up step 84. Alarms, including the time they occurred, will be transmitted to the printer and computer whenever they are first initiated, accepted and cleared. The protocol for the serial port is eight data bits, one stop bit, no parity.

### 2.13 AUXILIARY TEMPERATURE THERMOCOUPLE

A flue thermocouple must be connected to the AUX thermocouple input when combustibles display is required.

The AUX thermocouple may also be used to monitor and display any process temperature.

### 2.14 WATCHDOG TIMER

The watchdog timer is started if the microprocessor fails to pulse it within any one-second period, (ie. fails to run its normal program). The microprocessor will then be reset up to three times until normal operation is resumed. Reset cycles are displayed by the POWER light on the keyboard. A steady 'ON' light indicates normal operation. If the program has not resumed normal operation after three attempts to reset, the common alarm relay will be activated. The reset function will continue repeatedly after the alarm. If a successful reset is achieved, the alarm will be cancelled and the transmitter will continue to run normally.

### 2.15 BACK-UP BATTERY

The transmitter's RAM and real-time clock are backed up by a lithium battery in the event of power failure. All set-up variables are saved and the clock is kept running for approximately ten years with the power off. The battery module should be replaced every 8 years. (It is the battery shaped device clipped in a socket labelled M1.)

# INSTALLING & COMMISSIONING

## 3

### SECTION NUMBER

### INSTALLATION

- 3.1 MOUNTING THE TRANSMITTER
- 3.2a INSTALLING AN OXYGEN PROBE
- 3.2b INSTALLING A 1234 OXYGEN SENSOR
- 3.3 INSTALLING THE AUXILIARY THERMOCOUPLE
- 3.4 SHIELD CONNECTIONS
- 3.5 ELECTRICAL CONNECTIONS
- 3.6 HEATER INTERLOCK RELAYS
- 3.7a CONNECTING AN OXYGEN PROBE CABLE
- 3.7b CONNECTING A 1234 SENSOR CABLE
- 3.8 CONNECTING THE AUXILIARY THERMOCOUPLE (OPTIONAL)
- 3.9 CONNECTING THE OUTPUT CHANNELS
- 3.10 CONNECTING THE ALARMS
- 3.11 CONNECTING THE AUTOMATIC PURGE & CALIBRATION CHECK SYSTEM
- 3.12 CONNECTING REFERENCE AIR
- 3.13 CONNECTING THE DUAL FUEL INPUT
- 3.14 CONNECTING THE PRINTER
- 3.15 CONNECTING THE TRANSMITTER TO A MODBUS™ NETWORK

### COMMISSIONING

- 3.16 CONNECTING POWER
- 3.17 COMMISSIONING - SET-UP MODE
- 3.18 COMMISSIONING - RUN MODE
- 3.19 BURNER BY-PASS SWITCH
- 3.20 CHECKING ALARMS
- 3.21 PROBE CALIBRATION CHECK
- 3.22 FILTER PURGE SET-UP PROCEDURE
- 3.23 CALIBRATION CHECK GAS SET-UP PROCEDURE
- 3.24 DUST IN THE FLUE GAS
- 3.25 STRATIFICATION
- 3.26 CONNECTING A PRESSURE TRANSDUCER

## INSTALLATION

### 3.1 MOUNTING THE TRANSMITTER

Surface mount the transmitter case on to a flat surface or bracket, using the four mounting brackets provided. Make sure the ambient temperature is below 50°C, and that the radiated heat from furnaces and boilers is kept to a minimum.

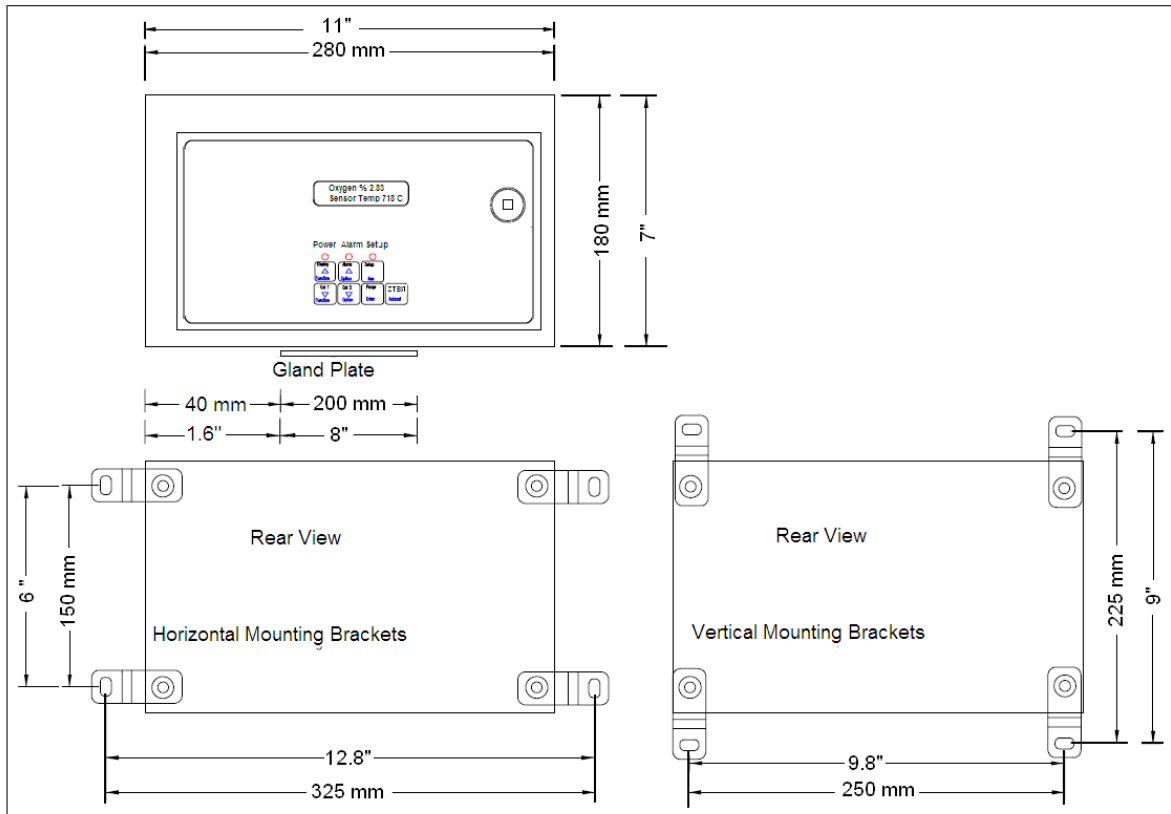

Case Mounting Dimensions

### 3.2a INSTALLING A 1231 OXYGEN PROBE

Weld a BSP or NPT socket to the flue in a suitable position for flue gas sensing. For the correct size of socket refer to probe data in Section 1. The closer to the source of combustion the smaller will be sensing lag time, allowing better control.

The probe has a typical response time of less than four seconds, so most of the delay time is normally the transit time of the gas from the point of combustion to the point of sensing.

Probes can be mounted at any angle. If there are any particulates in the flue gas, a filter can be omitted by pointing the probe vertically downwards. Otherwise the filters may have to be replaced periodically.

If installing a probe into a hot environment, slide the probe in slowly to avoid thermal shock to the internal ceramic parts. If the flue gas is 1000°C (1830°F), it should

## 9060-Zirconia Analyser

take approximately five minutes to install a 500 mm (20") probe, moving it in about 50 mm (2") steps.

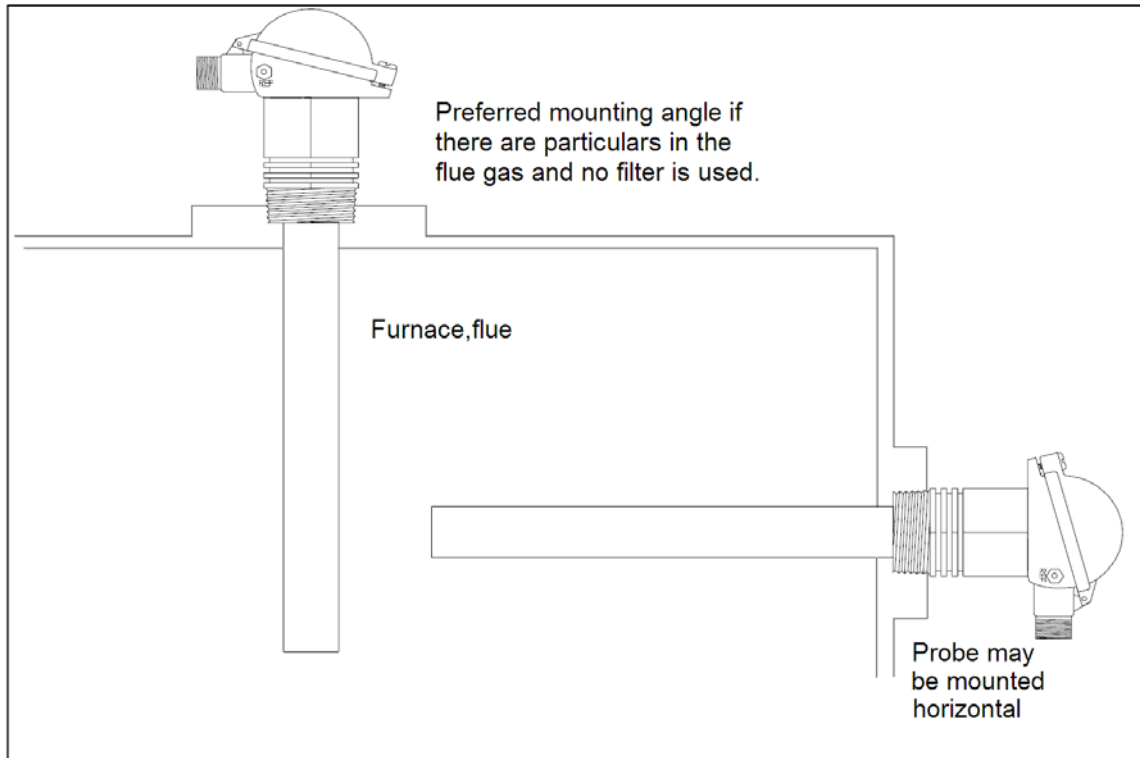

Oxygen Probe Mounting

### CAUTION

It is important that there is no air in leakage upstream of the oxygen sensing point, otherwise there will be a high oxygen reading.

If the probe is to be installed on a bend in the flue, it is best located on the outer circumference of the bend to avoid dead pockets of flue gas flow. While the standard 1231 probe with a 'U' length of 250 mm (10") will suit most low temperature flue applications, it is occasionally necessary to have a longer probe with the sensing tip in the center of the flue gas stream.

Although it is rare, occasionally a probe may sense oxygen vastly differently from the average reading in the flue gas. If it occurs, then the probe should be moved, or a longer probe installed. This phenomena is normally caused by stratification of the flue gas.

3.2b INSTALLING A 1234 OXYGEN SENSOR

**Mounting -** Screw the 1234 sensor to a wall or similar surface with the piping connections at the bottom.

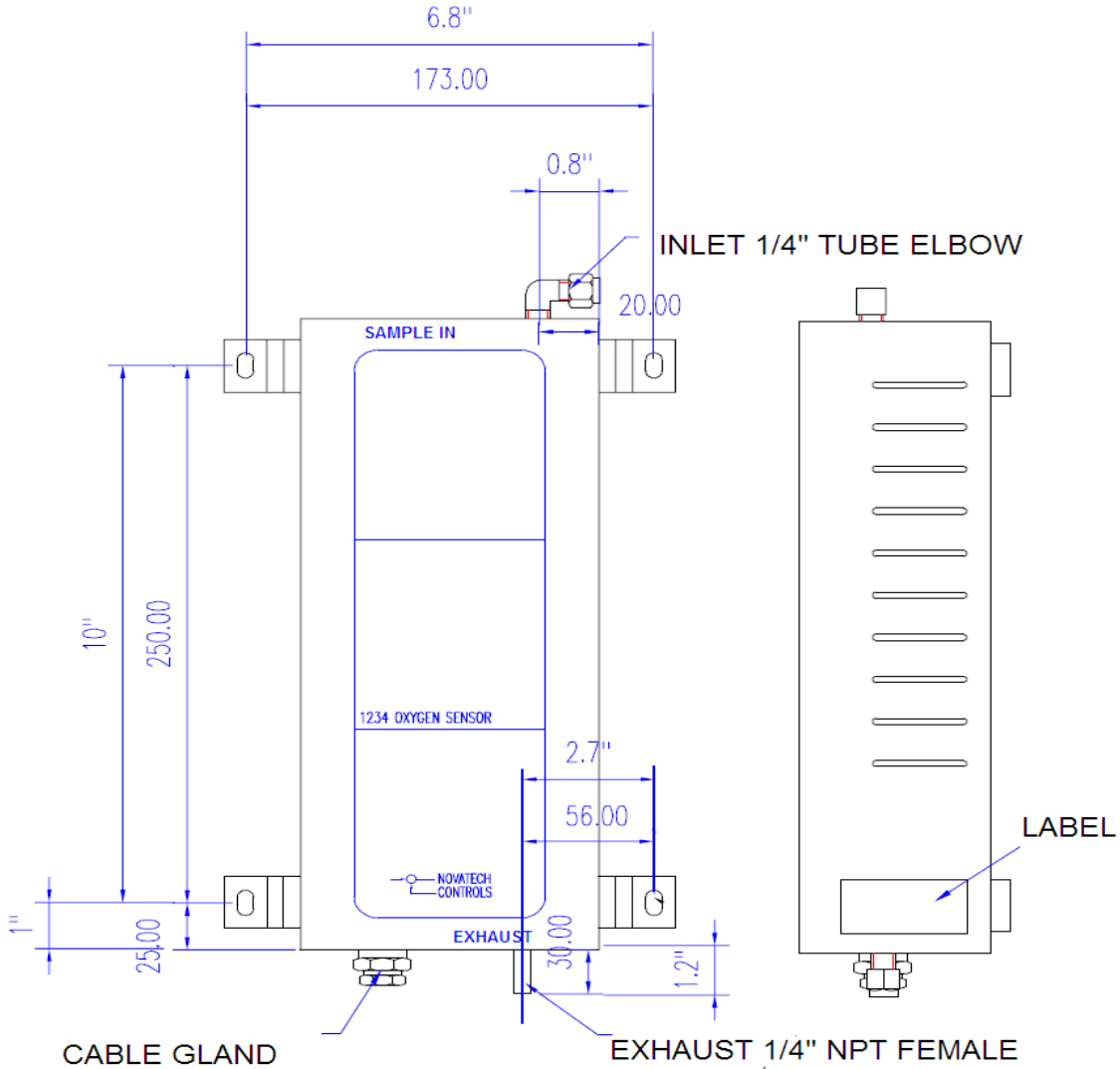

1234 Sensor Mounting Dimensions

## 9060-Zirconia Analyser

**Sample Piping** - Connect the gas sample piping to the “sample in” port. If the process, boiler, kiln or furnace has a positive pressure, no suction will be required. If the sample is under a negative pressure, connect a pump to the “inlet” port as shown below. The flow rate should be within the range of 1 to 5 litres/minute (120 to 600 scfm).

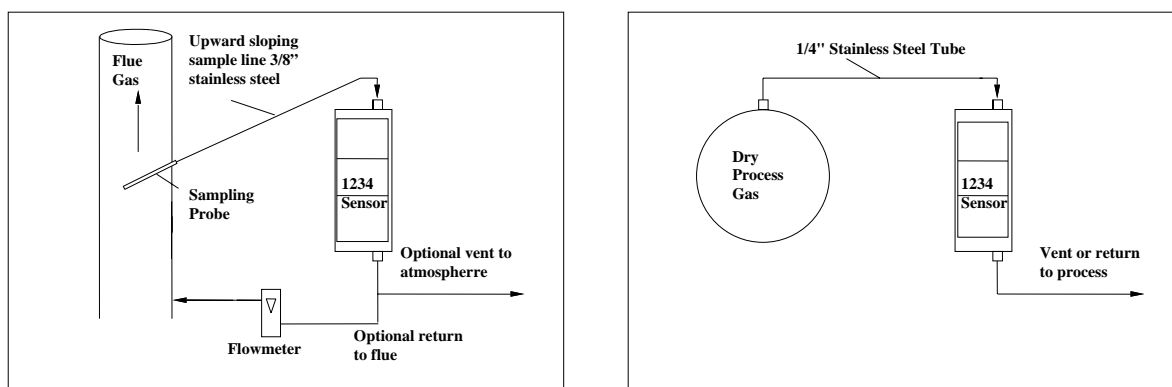

### 3.3 INSTALLING THE AUXILIARY THERMOCOUPLE

Weld a 1/2 inch BSP mounting socket to the flue within about 300 mm (12"), and upstream of the oxygen probe. The thermocouple should be of similar length to the oxygen probe to prevent flue temperature distribution errors.

### 3.4 SHIELD CONNECTIONS

All external wiring to the 9060 Analyser should be shielded. Do not connect shields at the field end. Simply clip off and insulate. An extra terminal strip may be required to connect all shields together. This should be supplied by the installer.

# 9060-Zirconia Analyser

## 3.5 ELECTRICAL CONNECTIONS

All wiring should comply with local electrical codes. The printed circuit boards are fully floating above earth. All earth and shield connections should be connected to the earth stud on the LHS inside the case. Before connection of mains power check that the 115 / 230 volt power selector switch is set to the correct voltage.

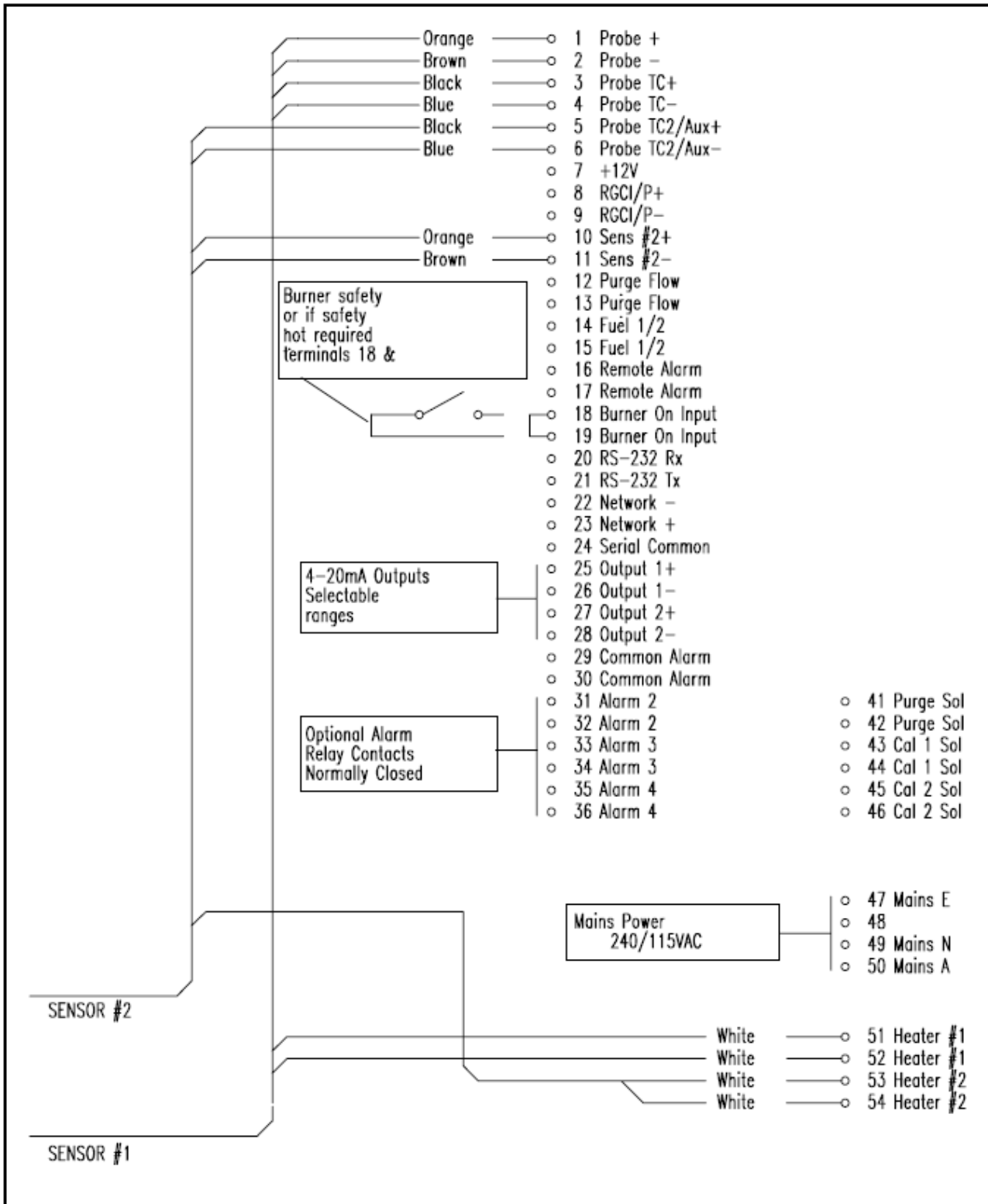

Connection Diagram for 9060 Analyser and one or two 1231 / 1234 Heated Sensors

## 9060-Zirconia Analyser

All wiring should comply with local electrical codes. The printed circuit boards are fully floating above earth. All earth and shield connections should be connected to the earth stud on the LHS inside the case. Before connection of mains power check that the 115 / 230 volt power selector switch is set to the correct voltage.

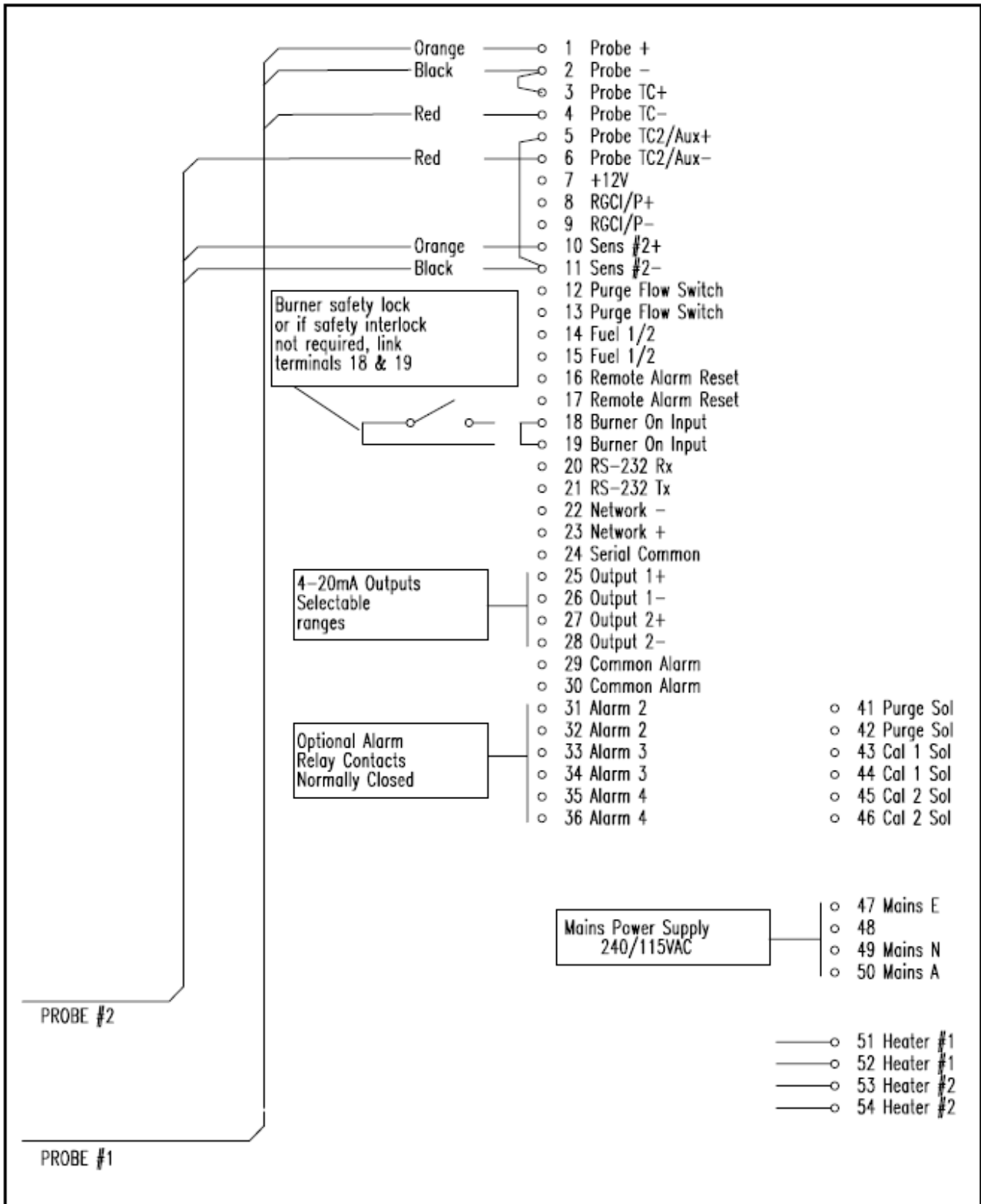

Connection Diagram for 9060 Analyser and one or two 1232 Unheated Sensors

## 3.6 HEATER INTERLOCK RELAYS

### CAUTION

Explosion protection for heated probes is achieved by switching the power to the probe heater off whenever the main fuel valve is closed.

The principle of safety is that if the main fuel valve is open then main flame has been established. With this primary source of ignition on, the probe heater can be safely switched on. The most dangerous situation is if fuel leaks into the combustion appliance when the fuel valve is closed. When power is removed from the main fuel valve the heater should also be switched off.

To achieve this protection, connect a main fuel valve voltage free contact to the 'BURNER ON SWITCH' terminals 18 & 19. When the main fuel valve is open, the voltage free contact should be closed. For installations where there is no risk of explosion, connect a link between terminals number 18 & 19.

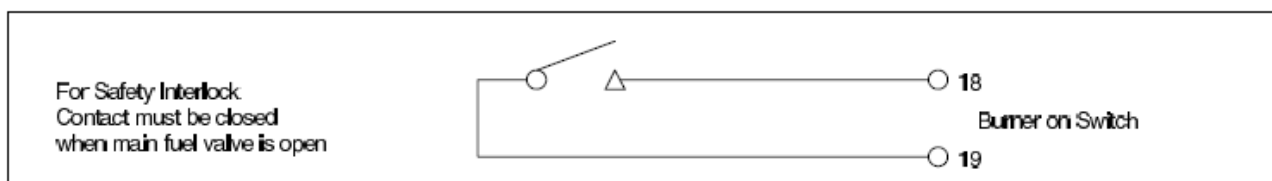

Heater Supply Interlock Connection for Heated Probes

If a safety interlock is not required, a wire must be connected between terminals 18 & 19 to enable –

- The heaters on heated probes
- Process alarms
- Auto-purge and auto-cal checking.

### 3.7a CONNECTING AN OXYGEN PROBE CABLE

Connect the probe lead as shown in the following drawings. Unheated probe leads have integral reference air tube. An adaptor has been supplied to connect this tube to quarter inch flexible PVC tubing, from the air pump or reference air supply.

# 9060-Zirconia Analyser

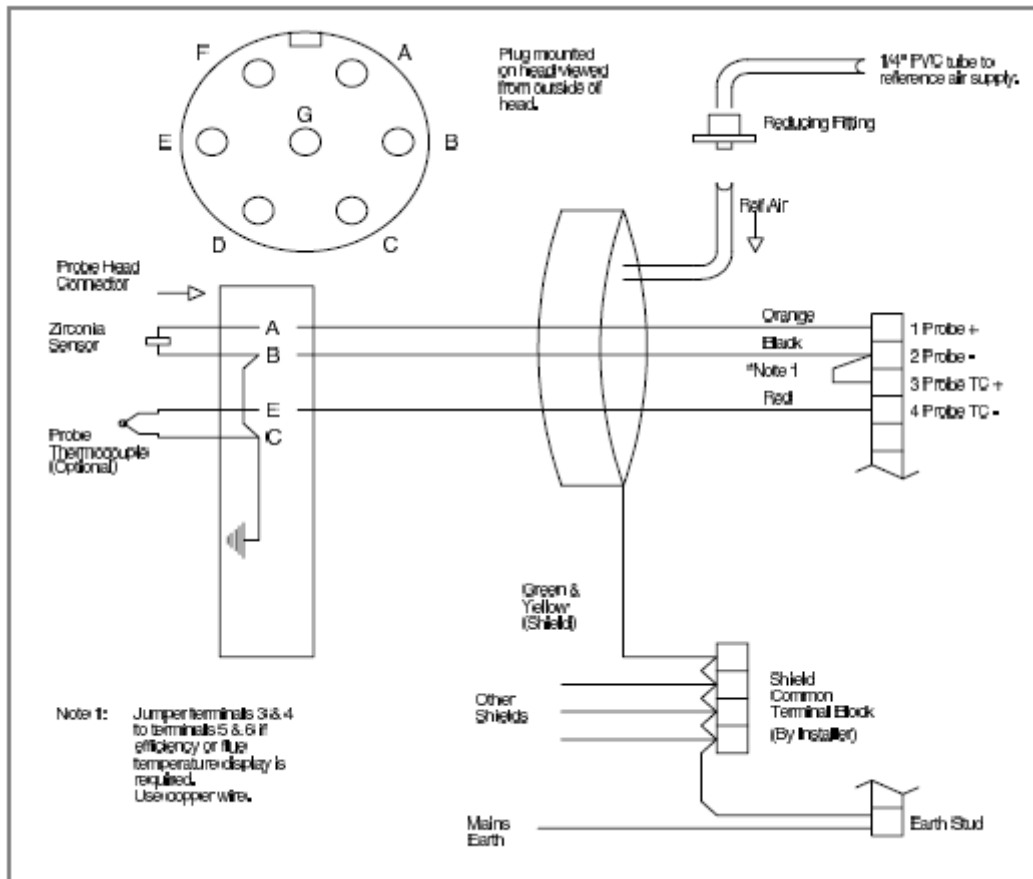

Connection of Probe Cable for Unheated Probes Models 1232.

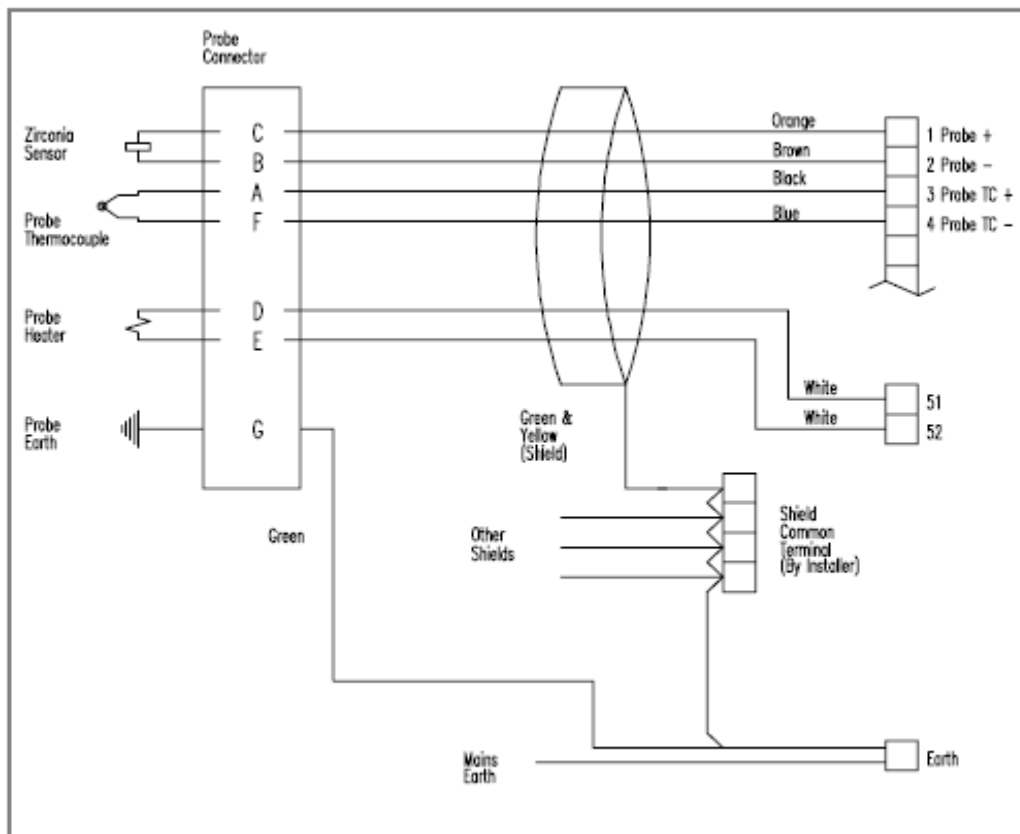

Connection of Probe Cable for Heated Probes Model 1231.

### 3.7b CONNECTING A 1234 SENSOR CABLE

Remove the two screws from the cable gland end of the 1234 sensor. Connect the wiring as shown below. Be sure to connect an earth to the earth stud. Replace the end plate. Tighten the cable gland onto the cable.

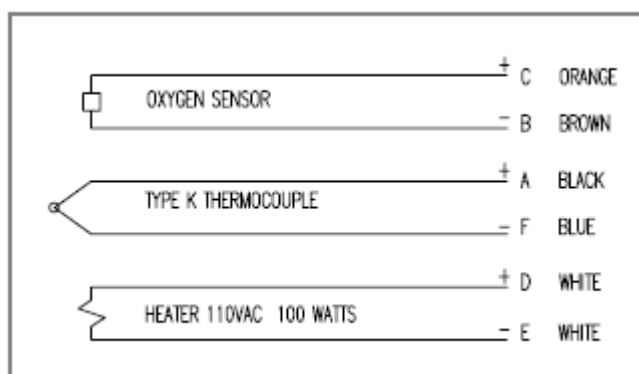

Connecting a 1234 Sensor Cable

### 3.8 CONNECTING THE AUXILIARY THERMOCOUPLE (OPTIONAL)

For 1231 heated probes, the auxiliary thermocouple must be a separate TC with the junction isolated from earth, mounted near to and upstream of the oxygen probe. It can be either a K or R type thermocouple. It is optional. If the auxiliary temperature is not to be displayed or transmitted, then an auxiliary TC is not necessary.

### 3.9 CONNECTING THE OUTPUT CHANNELS

The two 4 to 20 mA DC output channels are capable of driving into a 1000Ω load.

### 3.10 CONNECTING THE ALARMS

A common alarm, which should be connected for all installations initiates on alarms functions described below. Three additional alarm relays are available for selectable functions as listed in Section 4.2 and 4.3. Each relay has normally closed contacts. The contacts will open in alarm condition except for the optional horn function that operates with normally open contacts. Relays are connected as follows:

Relay	Terminal Numbers
Common Alarm	29 & 30
Alarm 2	31 & 32
Alarm 3	33 & 34
Alarm 4	35 & 36

**Common Alarms** All of the following conditions will cause a common alarm -

- ADC Calibration Fail
- DAC Calibration Fail
- Sensor 1 Fail
- Sensor 2 Fail\*
- Heater 1 Fail
- Heater 2 Fail\*
- Sensor 1 TC Open
- Sensor 2 TC Open\*
- Aux. TC Open

## 9060-Zirconia Analyser

Reference Air Pump Fail  
Reference Air Fail \*\*  
Mains Frequency Check fail  
Probe Filter Blocked  
Gas 1 Calibration Check Error  
Gas 2 Calibration Check Error  
Burner bypass Switch on  
Oxygen Deviation High\*  
BB RAM Fail  
Watchdog Timer

\* These alarms are only available if two sensors are selected

\*\* This alarm is only available if a flow sensor is installed in CN8 on the 1630-2 PCB

The watchdog timer is a special alarm. It will force the common alarm to activate in the event of a microprocessor failure. There will not be an alarm message displayed, but the transmitter will reset.

Alarms can be accepted by either pressing the alarm button (viewing the alarm messages), or by temporarily closing a switch connected to terminals 16 & 17, REM ALARM RESET.

**Alarm relay 2 to 4** Select any one or all of the following for each relay. Refer 5 to Section 5.5, steps 70 to 81

High oxygen  
Low oxygen  
Very low oxygen  
Probe or sensor under temperature  
Calibration check in progress  
Probe purge in progress  
Alarm horn function (Relay 4 only)

### 3.11 CONNECTING THE AUTOMATIC PURGE AND CALIBRATION CHECK SYSTEM

#### CAUTION

The purge and calibration solenoid valves are supplied with mains voltage. This supply has electrical shock danger to maintenance personnel. Always isolate the transmitter before working with the purge and calibration solenoid valves.

The on-line auto purge and calibration check system is optional. For details on its operation refer to Sections 1.3, 1.4, 2.9 and 2.10.

To automatically sense a blocked probe filter, a pressure sensor should be connected to the 'purge' line to the probe 'cal' port. It should be adjusted so that it energises just above the purge pressure with a new or clean filter installed. The switch contacts should be connected to terminals 12 & 13 (PURGE FL SWITCH).

If the filter is still blocked or partly blocked after an auto purge cycle, the pressure switch will energise and cause a 'Probe Filter Blocked' alarm.

After installation the purge/cal system should be tested thoroughly for leaks. Any leaks can cause significant errors if the flue is at negative pressure. If the flue is at positive pressure, an outward leak can cause corrosion in the purge/cal system piping and fittings.

## 9060-Zirconia Analyser

If probe/filter purging is required but a “Probe Filter Blocked” alarm is not required, link terminals 12 & 13.

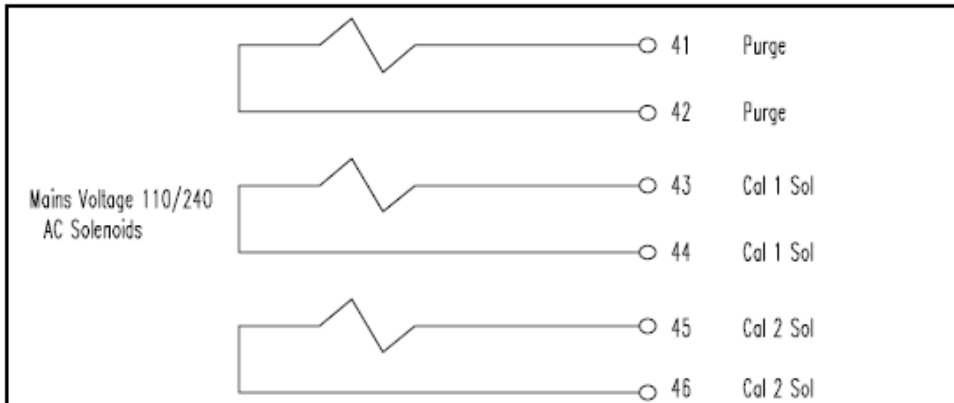

Automatic Purge & Calibration Check System Wiring Schematic

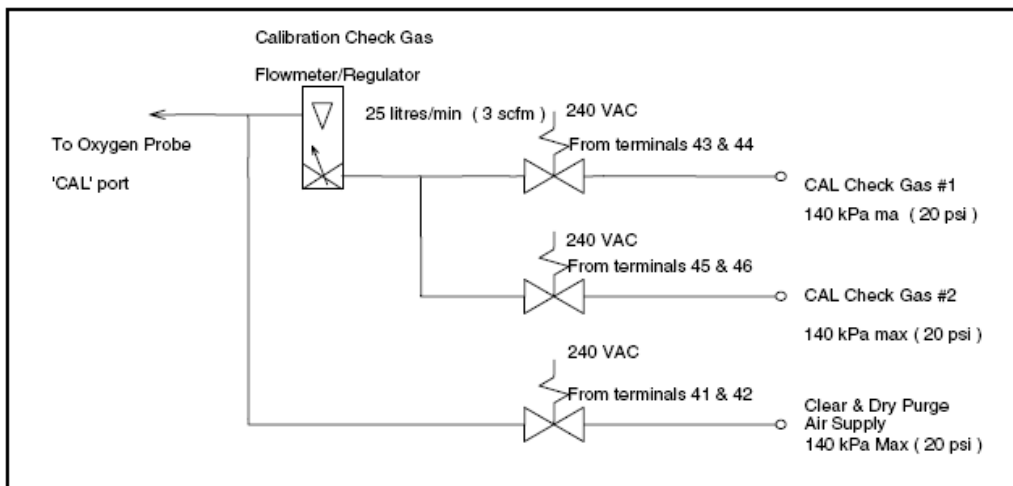

Automatic Purge & Calibration Check System Piping Schematic

### 3.12 CONNECTING REFERENCE AIR

For 1234 sensors, no reference air connection is required. For oxygen probes, a 1/4" tube connector on the transmitter should be connected via a nylon, copper or stainless steel tube to the 'REF' connector on the probe.

If two probes are being used, a "T" union must be supplied to provide reference air supply to both probes.

If 'Internal' is selected in set-up 85, and a reference airflow sensor is connected to CN8 on the 1630-2 (terminal) PCB, the reference air pump is cycled on and off each minute.

### 3.13 CONNECTING THE DUAL FUEL INPUT

If combustibles or maximum carbon dioxide display is required and the appliance is capable of firing more than one fuel, then an external contact must be connected for the transmitter to determine which fuel is being burnt.

## 9060-Zirconia Analyser

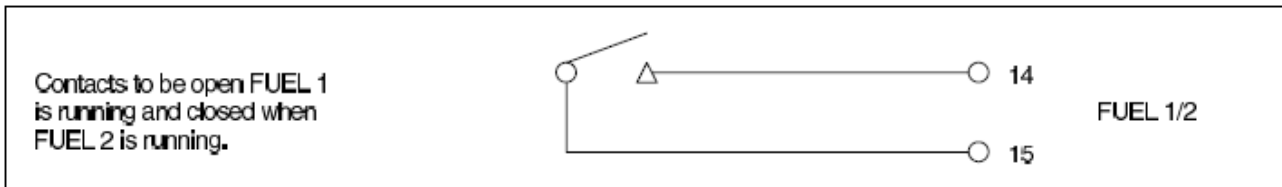

Fuel Selector Input Contact Connection

### 3.14 CONNECTING THE PRINTER

A printer with a serial port, or a data logger, or a computer terminal may be connected to RS 232-C or the network port. Data is logged out of the port as arranged in Set-up steps 82 and 83. The baud rate is selectable in set-up step 84. The RS-232 protocol for the serial port is eight data bits, one stop bit, no parity.

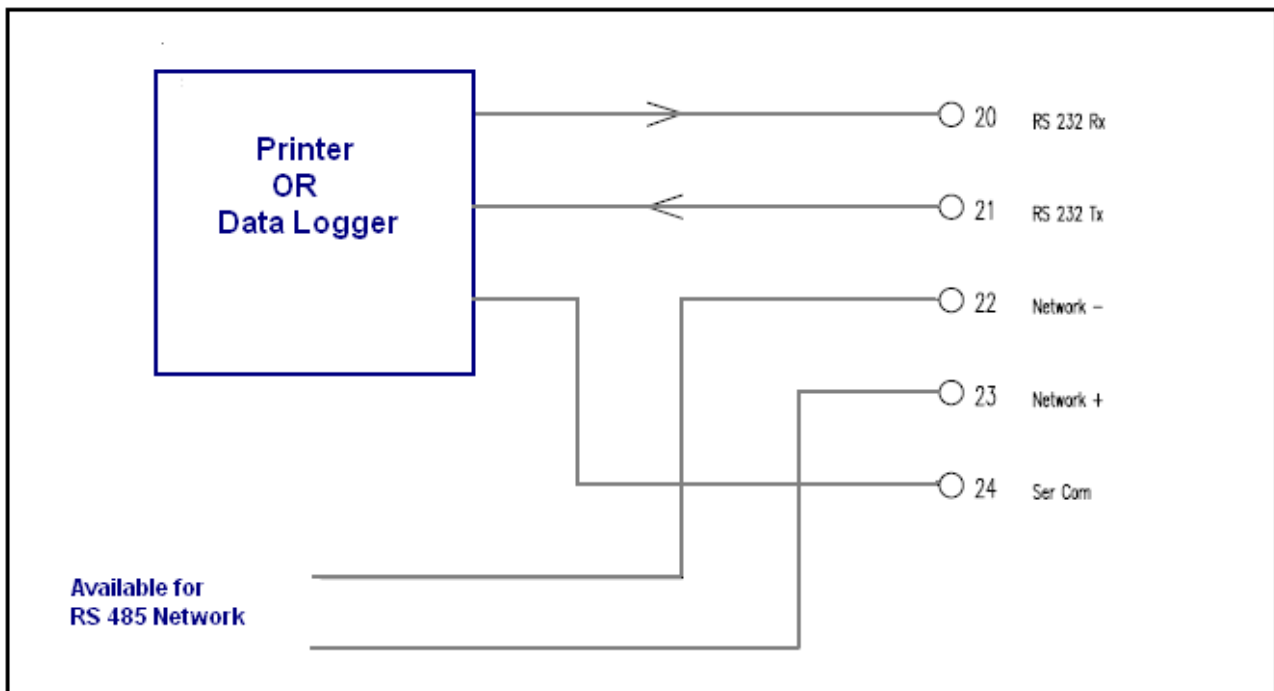

Serial Port Connections

### 3.15 CONNECTING THE TRANSMITTER TO A MODBUS™ NETWORK

The transmitter can be networked to other transmitters and to a network master. The network uses the transmitter's RS485 port. Up to 31 transmitters can be connected to the network, and can be interrogated by the Network Master.

#### **NOTE: Hardware Protocol Selection**

For the RS485 port on the transmitter to operate, the link LK3 on the 1630-1 printed circuit board (mounted on the door of the transmitter) must be set to the RS485 position. The LK3 is accessed by removing the cover from the door PCB. It is located at the bottom of the circuit board.

#### **NOTE: Terminating Resistor**

There is a terminating 100 ohm resistor fitted to the 1630-1 PCB. Link LK2, in the bottom left-hand corner of the PCB on the door, is used to connect the terminating resistor. Link LK2 must be removed on all transmitters except the transmitter on the end of the network line. If the network line from the transmitters is taken from the middle of the transmitter network string, a terminating resistor should be enabled with LK2 at each end of the network line.

**The protocol of the network is –**

- Baud Rate 9600
- Parity none
- Stop Bits 1
- RS485 Half Duplex
- Mode RTU (binary mode)

For more details see Section 2.12 and Appendix 6.

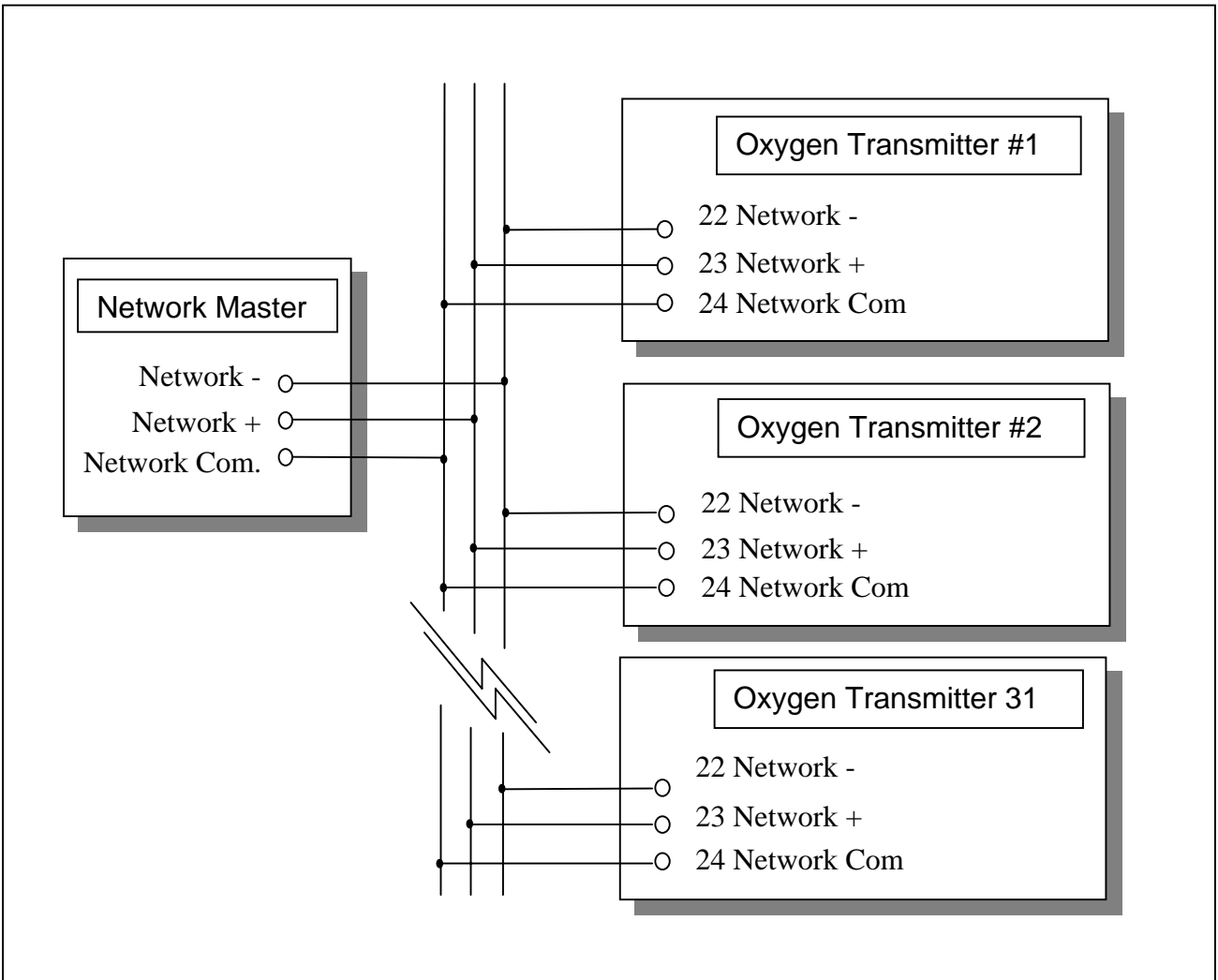

Network Connections

# COMMISSIONING

### 3.16 CONNECTING POWER

Before commissioning the probe, sensor or transmitter, read the CAUTION paragraphs at the front of this manual. Check that the mains supply voltage switch is set for the correct supply voltage, and that the green/yellow EARTH wire MUST be connected to earth.

### 3.17 COMMISSIONING - SET-UP MODE

Press the SET-UP button to select the 'SET-UP' mode. Most of the default settings of the functions will be correct, or will have been pre-set at the factory. Refer to Section 5.5 for more details.

Check the following set-up functions -

- 2 to 6 Date /time
- 7 to 10 Reference voltages
- 11 & 12 Probe offset
- 22 & 23 Sensor type
- 26 & 27 Output channel #1
- 28 to 30 Output channel #2
- 53 Auto purge
- 67 Auto gas calibration checking
- 70 to 78 Alarm set-up

### 3.18 COMMISSIONING - RUN MODE

When the transmitter is turned on it will go to RUN mode. The SET-UP/RUN button will toggle between the two modes. The upper line of the display will now read '% OXYGEN'. If the probe or sensor temperature is not above 650°C (1200°F), a "Probe Low Temperature" message is flashed on the lower line. The probe or sensor temperature can be checked on the lower line of the display.

### 3.19 BURNER BY-PASS SWITCH

Heated probes and sensors should have their heater supply interlocked. If the combustion appliance is not running, then power will not be supplied to the heater. To commission an oxygen probe when the main burner is turned off, switch power off the transmitter, remove the probe from the flue or the flue connection from the 1234 sensor.

Re-apply power to the transmitter, press the BURNER BY-PASS switch into the 'DOWN' or 'ON' position. This will apply power to the probe or sensor heater even when the plant is not running. The offset can now be set and calibration checked with appropriate calibration check gases (typically 2% oxygen in nitrogen).

Ensure that the burner by-pass switch and the power are turned off before the probe or sensor is re-installed. An alarm will occur if the BURNER BY-PASS switch is turned on (down) during normal operation.

### 3.20 CHECKING THE ALARMS

If any alarms are present the alarm LED will be lit, either flashing or steady. To interpret the alarms, press the alarm button until all alarm functions have been displayed. Rectify

the cause of each alarm until no further alarms appear on the display. For details on the operation of the alarm button and the alarm functions refer to Section 4.

### 3.21 PROBE OR SENSOR CALIBRATION

The zirconia sensor provides an absolute measurement of oxygen partial pressure. There are no calibration adjustments, apart from 'SENSOR OFFSET', for the probe or sensor. The zirconia sensor EMF is either correct or replacement is required. To check that the probe or sensor is functioning correctly, firstly check that the high impedance alarm, 'SENSOR FAIL', is not active. The actual impedance can be displayed on the lower line. It should be less than 9 K $\Omega$  at 720°C (1320°F).

Once it has been established that the impedance is normal, the offset may be set using the millivolt level marked on the oxygen probe or sensor. Refer to Section 5.5.11. The probe offset can be tested on site. A small flow of air must be admitted to both the 'REF' and 'CAL' ports when testing the probe offset. If the probe is in the process, the air must fully purge the probe sensor without interference from the process gas sample. Teledyne probes can easily achieve this with or without a probe filter and a gas flow of only 1 to 5 litres/minute (120 to 600 scfm) for a 1231 probe and up to 20 litres/minute (2400scfm) for an unheated probe.

### 3.22 FILTER PURGING

Purging probe filters is controlled from the 'PURGE' button on the transmitter when in 'RUN' mode. If 'AUTO PURGE' has been enabled in set-up 53, pressing the PURGE button will start the automatic cycle. Pressing any other button will cancel the auto purge cycle. If AUTO PURGE was not enabled, the purge solenoid will only stay open for as long as the button is pressed. Gradually adjust the purge air supply regulator, increasing the pressure until sufficient flow is obtained to clear the filter. This is best checked with a dirty filter after a period of operation, by withdrawing the probe from service and watching any build up on the filter being blown off at the set pressure. Normally 30 kPa (5 psi) is adequate but the air pressure may be set as high as 100 kPa (15 psi).

### 3.23 CALIBRATION GAS CHECK

If the installation has a filter purge facility, set this up first. Refer to the previous paragraph. Press the 'CAL 1' or 'CAL 2' button while in 'SET UP' mode to obtain a reasonable flow through the calibration check gas flow meter. If air is being used as a calibration check gas, use the air from the regulator for filter purge. Then, when setting up a gas for calibration checking, set the pressure from the calibration gas cylinder so that it is the same as the pressure set on the air regulator. Then the setting on the rotameter / flow regulator will be the same as that for the airflow. The flow required is 1 to 5 litres/minute (120 to 600 scfm) ) for a 1231 probe and up to 20 litres/minute (2400scfm) for an unheated probe.

Air is not the best gas for calibration checking on a zirconia sensor. The output of a zirconia sensor with air on both sides of the sensor is zero millivolts. It is better to choose a gas value which provides a reasonable output from the sensor and which is near to the process oxygen level. A cylinder with 2% oxygen in nitrogen is a commonly used calibration gas. The maximum pressure on the calibration check gas cylinder regulators is 100 kPa (15 psi).

## 9060-Zirconia Analyser

Note: If two probes was selected in set-up 1, 'Cal Gas 2' must be connected to probe 2.

### 3.24 DUST IN THE FLUE GAS

For unheated probes with no filter, entrained solids or dust in the flue gas does not present a problem unless the dust, when settled, is not porous. Allow the dust in the process to build up on the probe. It will form a porous layer slowing the response time. To avoid mechanical abrasion of the electrode material in installations with unheated oxygen probes, pack 'SAFFIL' or equivalent alumina based ceramic fibre in the sensing holes to protect the electrode. Do not use silica based ceramic fibres such as 'KAOWOOL', which can attack the electrode at high temperatures. Once the dust has built up the response time of the probe will be slower.

For heated probes the preferred method of mounting for dust-laden applications is facing vertically downwards with the filter removed. Probes can also be mounted horizontally with no filter with some dusts. An occasional automatic back purge is helpful in this case.

Normally heated probes are supplied with filters for applications with particulates in the flue gas. The probe response time should be tested when the probe is first installed, and then regularly until it remains constant for a significant period. Filter purging should be set up on the time periods determined by these tests. To test the probe response time, use a stopwatch to obtain the time for a probe to achieve a 63 % change from one reading to another. If a probe filter blocks completely in a short period of time, then there is no option but to use the probe without the filter. A trial probe with filter can be installed to test whether a filter blockage is likely to occur.

### 3.25 STRATIFICATION

If the transmitter and probe have been fully tested and the oxygen readings in the flue gas are incorrect, gas stratification may be occurring. The phenomena cannot be anticipated for any particular installation. Generally, large flues have oxygen differences of approximately one percent across the flue. Occasionally an oxygen error of several percent may occur in a flue of any size. Moving the probe to a new location normally solves this problem.

The effects of stratification can be reduced by using two probes and averaging the two oxygen readings. This can be achieved within a Teledyne 9060 Analyser controlling two probes.

### 3.26 CONNECTING A PRESSURE TRANSDUCER

If the process gas pressure varies more than 4" WG and therefore requires dynamic compensation, connect a pressure transducer as shown below. Place the link on LK1 in the 4-20mA position, this connects an on-board 47Ω resistor to terminals 8 & 9. A pressure change of 4" WG will cause an oxygen error of about 1% of the oxygen reading.

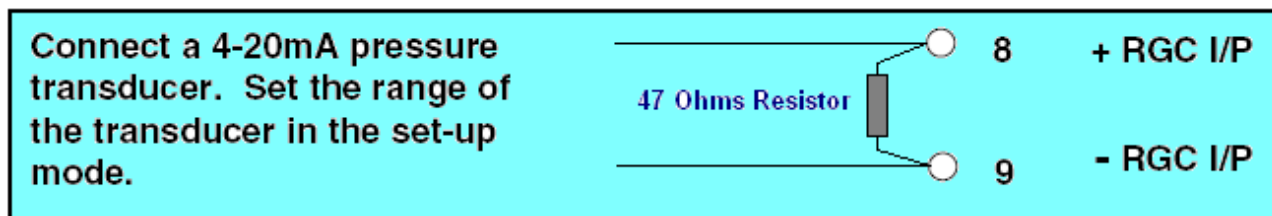

Pressure Transducer Connection

There are no adjustments for the zero or span of the pressure transducer input and the pressure cannot be displayed on the lower line. However the input calibration can be checked with the following procedure.

Note: This procedure will check that the 4-20mA input will transfer correctly to an oxygen value that is correctly compensated for pressure. The zero and full scale pressure range of the transducer does not have to be used for the calibration. Because the scaling is manipulated digitally, the scale can be changed to suit the pressure transducer after the calibration.

1. Configure the set-up options as below –
  34. Flue Pressure Setup- "Variable Input"
  35. Flue Pressure Input Zero Value- 0 mb
  36. Flue Pressure Input Span Value- 1000 mb
2. Connect a 4-20mA generator to the input terminals 8 & 9. Make sure that the 47 ohm resistor is across the input terminals 8 & 9.
3. Connect either an oxygen probe or a mV generator to simulate 2% oxygen. This will require 50.26mV between terminals 1 (+) and 2 (-), and 29mV between terminals 3 (+) and 4 (-). Adjust the 29mV until the transmitter reads 720 °C when selected on the lower line.
4. Set the 4-20mA generator to 4mA. The transmitter should read 2.0% oxygen.
5. Set the 4-20mA generator to 20mA. The transmitter should read 1.00% oxygen.

If the oxygen values do not read as indicated in numbers 4 and 5 above, check –

- (a) The set-up items 34, 35 and 36 are set as stated in number 1.
- (b) The polarity of the input signal.
- (c) The oxygen level with the 4-20mA generator disconnected. It should be 2.0%.

# OPERATOR FUNCTIONS

## 4

SECTION  
NUMBER

- |     |                      |
|-----|----------------------|
| 4.1 | DISPLAY BUTTON       |
| 4.2 | ALARM BUTTON         |
| 4.3 | ALARM SCHEDULE       |
| 4.4 | POWER LAMP           |
| 4.5 | BURNER BYPASS SWITCH |
| 4.6 | DISPLAY BACKLIGHT    |

## OPERATOR FUNCTIONS (RUN MODE)

### 4.1 DISPLAY BUTTON

The upper line on the display will always read % oxygen (or ppm, selectable in step 31 in the set-up menu Section 5.5) for sensor 1. The following are available for display on the lower line.

1. AVERAGE OF PROBE 1 & PROBE 2 OXYGEN,
2. PROBE 2 OXYGEN,
3. PROBE 1 EMF (millivolts)
4. PROBE 2 EMF (millivolts)
5. PROBE 1 TEMPERATURE
6. PROBE 2 TEMPERATURE
7. PROBE 1 IMPEDANCE,
8. PROBE 2 IMPEDANCE, A measure of integrity of the sensor's electrode, the part of the probe that normally wears out first.
9. AUXILIARY TEMPERATURE
10. AMBIENT TEMPERATURE
11. OXYGEN DEFICIENCY %
12. COMBUSTIBLES %
13. % CARBON DIOXIDE, dry. Calculated from the oxygen reading. Assumes complete combustion.
14. RUN HOURS SINCE LAST SERVICE
15. DATE OF LAST SERVICE

Any number of these variables can be displayed sequentially by pressing the 'DISPLAY' button. Items can be selected for display or deleted in step 33, in the set-up menu Section 5.5, on the keyboard. In addition to the above lower line displays, the transmitter will automatically display:

- "Sensor 1 Temp Low", when sensor one is below 650°C (1200°F)
- "Sensor 2 Temp Low", when sensor two is below 650°C (1200°F)
- "Gas 1 ON", "Gas 2 ON" for Calibration check Gas 1 or 2
- "Purging Probe"
- "Sensor 1 Thermocouple Wrong Polarity"
- "Sensor 2 Thermocouple Wrong Polarity"
- "Aux Thermocouple Wrong Polarity"

#### NOTE:

1. The run time will be the period of time the BURNER ON SWITCH (terminals 18 & 19) contact is closed (ie. main fuel valve open). If no explosion protection is required, a permanent bridge between the BURNER ON SWITCH terminals will register run time whenever the transmitter is powered.
2. This timer can be used as a probe replacement and/or boiler service schedule aid. Changing the 'SERVICE DAY' in set-up mode on the keyboard resets the start time.
3. If you hold the display button down as you switch on the power, the maximum ambient temperature which the instrument has been subjected to, will be displayed. This temperature should be less than 50°C (130°F).

### 4.2 ALARM BUTTON

Repeatedly pressing the 'ALARM' button will produce alarm displays in sequence on the lower line of the LCD display. If an alarm has cleared prior to pressing the 'ALARM' button, it will not re-appear on a second run through the alarms. Active alarms which have been previously displayed will have 'acc' (accepted in lower case), displayed alongside. New alarms will not have 'ACC' (in upper case) displayed until a second press of the 'ALARM' button. After the last active alarm is indicated, the lower line of the display will return to the last displayed lower line variable. Alarms may also be accepted remotely by a temporary closure of a switch connected to terminal 16 & 17, 'REMOTE ALARM RESET'.

The alarm 'LED' will flash when there is an un-accepted alarm. Pressing the 'ALARM' button will cause the LED to go steady if any alarms are still active, or extinguish if there are no active alarms. The horn relay will operate when an alarm occurs. Pressing 'ALARM' will mute a horn relay (if one of the user configurable relays have been selected as a 'Horn' relay) which will re-initiate on any new alarms.

### 4.3 ALARM SCHEDULE

#### 4.3.1 SUMMARY OF ALARMS - COMMON ALARM

1. 'Sensor 1 Fail'

2. 'Sensor 2 Fail'

Oxygen sensor or electrode failure (high impedance); (inhibited under 650°C (1200°F)).

3. 'Heater 1 Fail'

4. 'Heater 2 Fail'

In the first 20 minutes of power being applied to the heater after being switched on, this alarm will not occur, but a 'Sensor 1(2) Lo Temp' display will occur and common alarm relay will be activated. Refer to Section 6.11. If an ADC alarm occurs, the heaters will automatically be turned off.

5. 'Sensor 1 TC Open'

6. 'Sensor 2 TC Open'

Probe thermocouple is open circuit. The heater in heated probes will switch off.

7. 'Aux TC Open'

Stack thermocouple is open circuit. If the thermocouple is not needed, select "NO T/C" for "Aux TC Type" or place a short circuit between terminals 5 & 6.

8. 'Ref Pump Fail'

The reference air pump in the transmitter has failed.

9. 'Ref Air Fail'

The reference gas supply from the air pump in the transmitter to the probe is blocked, or there is not sufficient airflow.

10. 'ADC Cal Fail'

The analog to digital converter has been found to fall outside the normal calibration specifications. In this case the sensor heater will automatically be turned off.

### 11. 'Mains Freq'

The sample of the mains frequency has failed.

### 12. 'DAC Cal Fail'

The digital to analog and voltage isolator circuit has been found to fall outside the normal calibration specifications. This check is only performed when the 'AUTO CAL' button is pressed. Refer to Section 6.3.

### 13. 'Probe Filter'

Blocked probe filter. This test is only performed when automatic purging of the probe is selected. Refer to step 53 in the set-up menu Section 5.5. This alarm will not reset until the next purge cycle that can be initiated manually or automatically.

### 14. 'Gas 1 Cal Err'

Probe does not correctly calibrate to calibration check gas 1.

### 15. 'Gas 2 Cal Err'

Probe does not correctly calibrate to calibration check gas 2.

### 16. 'Burner bypass'

The safety interlock relay has been bypassed by turning on the 'BURNER BYPASS' switch on the terminal printed circuit board. Refer to Section 3.19

### 17. 'Oxygen Deviation High'

The oxygen as read by sensor 1 differs from the oxygen read by sensor 2 by an amount greater than the level set in step 75 in the set-up menu Section 5.5, for a period longer than that set in step 76. This alarm is only available if 'Two Sensors' is selected in set-up 1.

### 18. 'Watchdog Timer'

Microprocessor error. This alarm will not appear on the display. The common alarm relay will be forced open circuit.

If the watchdog timer senses a malfunction in the microprocessor, it will attempt to reset the transmitter every 2 seconds. After two resets the alarm relay contacts will go open circuit.

### 19. 'BBRAM Fail'

The battery backed memory module has failed in service. The device normally lasts 10 years. It is the plug-in battery like module on the 1630 -1 board, labelled M1.

### 20. 'Htr SSR Fail'

One of the two solid state relays that drive the heaters in the oxygen sensors has failed. The electro-mechanical relay RL7 will cut off the heater to prevent further damage.

### 4.3.2 SUMMARY OF ALARMS - SELECTABLE ALARMS

There are three user configurable alarm relays. Any or all of the following functions can be selected for each relay.

**NOTE:** The process alarms will only be activated if enabled in set-up 70.

#### 21. 'O<sub>2</sub>% Low'

The measured oxygen level is below the level set in set-up 73, and the alarm delay set in set-up 74 has expired. See step 64 in the set-up menu Section 5.5 for more details.

#### 22. 'O<sub>2</sub>% Very Low'

The measured oxygen level is below the level set in set-up 77, and the alarm delay set in set-up 78 has expired. See step 66 in the set-up menu Section 5.5 for more details.

#### 23. 'O<sub>2</sub>% High'

The measured oxygen level is above the level set in set-up 71, and the alarm delay set in set-up 72 has expired. See step 62 in the set-up menu Section 5.5 for more details.

#### 24. 'Probe Temperature'

The probe temperature is under 650°C (1200°F). The oxygen reading is therefore invalid. If the probe heater has been on for more than 20 minutes and the temperature is less than 650°C (1200°F) a 'heater fail' alarm will occur.

**NOTE:**

The 'Probe Temp' relay function is used with unheated probes to indicate oxygen reading is invalid (the probe is below 650°C (1200°F) ), in case the process temperature falls below this level. With heated probes this relay will be de-energised while the probe is heating up from ambient, making the contacts open circuit.

#### 25. 'Cal in Progress'

A calibration check is occurring, either manual ( in RUN mode) or automatic

#### Probe Purge

A probe purge is occurring, either manual ( in RUN mode) or automatic

#### 26. Alarm Horn

This is not an alarm condition. If one of the three user configurable alarm relays have 'Alarm Horn' enabled; the relay will have closed contacts only when there is an unaccepted alarm on the transmitter. Press the alarm button twice to accept any new alarm and to cancel the horn relay. This is only available on relay 4.

### 4.3.3 ALARM RELAYS

The alarm relays are fail safe. That is, the contacts will be closed during normal operation, and will be open circuit if there is an alarm or if the power is removed from the transmitter.

## 4.4 POWER LAMP

Illuminates when power is connected to the transmitter. If the lamp is flashing, the watchdog timer is attempting to reset the microprocessor. Replace the 1630-1 microprocessor PCB.

### 4.5 BURNER BYPASS SWITCH

This switch is mounted on the terminal PCB near the POWER switch.

Before the heater in a heated probe, or the alarms will be enabled, the probe must be enabled. There are two ways of doing this.

Use the safety interlock on terminals 18 & 19 (BURNER ON switch), or press the BURNER BYPASS switch to the ON position. While the BURNER BYPASS switch is on there will be an alarm, "Burner Bypass".

If it is not needed to have the transmitter interlocked with the combustion appliance terminals 18 & 19 can be connected together.

### 4.6 DISPLAY BACKLIGHT

If the ambient temperature measured inside the transmitter cabinet exceeds 35°C, the backlight will be turned off one minute after the keypad is used. This is aimed at reducing one of the major sources of heat within the cabinet when the ambient temperature is high. The backlight will come on again as soon as a button is pressed.

The internal reference air pump (if fitted) will start cycling on and off every minute, above 35°C.

# SETTING UP THE TRANSMITTER

## 5

### SECTION NUMBER

- 5.1 SET-UP MODE SUMMARY
- 5.2 SET-UP & RUN MODES
- 5.3 FUNCTION SELECT
- 5.4 ENTER OPTION OR VALUE
- 5.5 SET-UP FUNCTION DETAILS

## SET-UP MODE SUMMARY

### 5.1 SET-UP MODE FUNCTIONS

- 1 Number of Sensors
- 2 Calendar Year
- 3 Calendar Month
- 4 Calendar Day
- 5 Real time clock Hour
- 6 Real time clock Minutes
- 7 Reference voltage #1
- 8 Reference voltage #2
- 9 Reference voltage #3
- 10 Reference voltage #4
- 11 Sensor 1 offset
- 12 Sensor 2 offset
- 13 Output channel number 1 calibration
- 14 Output channel number 1 calibration, 4mA trim
- 15 Output channel number 1 calibration, 20mA trim
- 16 Output channel number 2 calibration
- 17 Output channel number 2 calibration, 4mA trim
- 18 Output channel number 2 calibration, 20mA trim
- 19 Service record year
- 20 Service record month
- 21 Service record day
- 22 Sensor 1 Type
- 23 Sensor 2 Type
- 24 Sensor 1 Thermocouple Type
- 25 Sensor 2, Auxiliary Thermocouple Type
- 26 Transmitter Output Channel 1 scale
- 27 Transmitter Span Channel 1
- 28 Transmitter Output Channel 2 scale
- 29 Transmitter Zero Channel 2
- 30 Transmitter Span Channel 2
- 31 Top Line Display Units, % or ppm
- 32 Centigrade/Fahrenheit Selection
- 33 Lower Line Display Functions
- 34 Flue Pressure, Fixed/Variable
- 35 Flue Pressure Input Zero Level
- 36 Flue Pressure Input Span Level
- 37 Flue Pressure mm/inches/kilopascals
- 38 Flue Pressure Value

Set-up steps 39 to 51 will be skipped automatically if combustibles, maximum CO<sub>2</sub> or oxygen deficiency are not selected in steps 28, 33 or 82.

- 39 Single or Dual Fuel
- 40 Fuel #1 'A' Value
- 41 Fuel #1 'H' Value
- 42 Fuel #1 'O' Value
- 43 Fuel #1 'N' Value

## 9060-Zirconia Analyser

44 Fuel #1 'S' Value

45 Fuel #1 'M' Value

Set-up steps 46 to 51 will be skipped automatically if 'Single Fuel' is selected in set-up step 39.

46 Fuel #2 'A' Value

47 Fuel #2 'H' Value

48 Fuel #2 'O' Value

49 Fuel #2 'N' Value

50 Fuel #2 'S' Value

51 Fuel #2 'M' Value

52 Purge/Cal Time

53 Automatic Purge

Set-up steps 54 to 56 will be skipped automatically if 'No' is selected in set-up step 53.

54 Time between Purges

55 Purge Duration

56 Purge Freeze Time

57 Number of Cal Gases

Set-up steps 58 to 69 may be skipped automatically, depending on the selection in set-up step 57.

58 Oxygen Content of Cal Gas 1

59 Maximum Acceptable Positive Error Gas 1

60 Maximum Acceptable Negative Error Gas 1

61 Period Between Gas 1 Autocal

62 Duration of Autocal Gas 1

63 Freeze Time Gas 1

64 Oxygen Content Of Cal Gas 2

65 Maximum Acceptable Positive Error Gas 2

66 Maximum Acceptable Negative Error Gas 2

67 Period Between Gas 2 Autocal

68 Duration of Autocal Gas 2

69 Freeze Time Gas 2

70 Process alarm enable

Set-up steps 71 to 78 will be skipped automatically if 'No' is selected in set-up step 70.

71 High oxygen alarm level

72 High oxygen alarm delay time

73 Low oxygen alarm level

74 Low oxygen alarm delay time

75 Oxygen Deviation Alarm (2 probes)

76 Oxygen Deviation Alarm Delay (2 probes)

77 Very low oxygen alarm level

78 Very low oxygen alarm delay time

79 Alarm relay number 2 function select

80 Alarm relay number 3 function select

81 Alarm relay number 4 function select

- 82 Data to Print
- 83 Print Log Period
- 84 Printer Baud Rate
  
- 85 Reference air pump Internal/External/Inst air
- 86 Reference air RH if 'Instrument Air' selected in Set-up 85.
- 87 Damping factor
- 88 MODBUS™ Address

The "Extended Set-up Menus" steps 89 to 97 will be skipped unless the extended menus are enabled. See Set-up 5.2 for more details.

- 89 Reference pump cycle time.
- 90 Low oxygen calibration factor, sensor #1.
- 91 Low oxygen calibration factor, sensor #2.
- 92 Gas calibrate / check selection.
- 93 Oxygen mid point calibration factor #1.
- 94 Oxygen mid point calibration factor #2.
- 95 4-20mA output limit enable option.
- 96 Solid state relay fail alarm setting.
- 97 Heater solid state relay swapping function.

### 5.2 SET-UP & RUN MODES

For the SET-UP mode keyboard to operate, press the SET-UP/RUN button. The set-up light will come on when the set-up mode has been entered.

#### NOTE:

Set-up mode cannot be entered if the keyboard lock switch (SW1) on the inside of the transmitter is in the UP position. The keyboard lock switch can be found on the door PCB (1630-1), on the lock side, at the top. If access is attempted while the keyboard is locked, the message '**Illegal Access**' will be displayed.

While the transmitter is in set-up mode the outputs will be frozen. All of the functions written in BLUE will now operate. If there are not any buttons pressed for 1 minute the transmitter will automatically revert to RUN mode.

If purges or an auto-calibration check occurs while the transmitter is in set-up mode, they will be delayed until the transmitter is returned to RUN mode.

To cancel an automatic purge or calibration check cycle, press AUTO CAL button while in RUN mode.

The Extended Menu can be seen if the Setup button is pressed before power is applied to the transmitter, and held until the display shows the words "Extended Menu".

### 5.3 FUNCTION SELECT

When the SET-UP mode is entered, the transmitter will automatically read the last set-up function selected.

To select other functions, operate the 'FUNCTION ▲' button to increment to the next function, or 'FUNCTION ▼' to decrement to the previous function.

## 5.4 ENTER OPTION OR VALUE

### A. Options.

To step through the available options for each function press the 'OPTION ▲' or 'OPTION ▼' buttons.

When the required option is selected press the 'ENTER' button. An asterisk will then appear alongside the option selected. When stepping through the set-up functions, the display will always first indicate the last options entered. The 'Lower Line Select' and 'Data To Print' set-up items 33 and 82 are multiple options. One or more options may be selected for these functions.

### B. Values

To set a value for a particular function press the 'OPTION ▲' button to increase the value and the 'OPTION ▼' button to decrease the value. A momentary press will change the value one digit. Holding the button will change the value more quickly. Once the correct option or value is displayed it can be entered into the transmitter's memory by pressing the 'ENTER' button. When a value has been entered an asterisk will appear at the R.H.S. of the lower line.

### 9060 Oxygen Analyser Keyboard

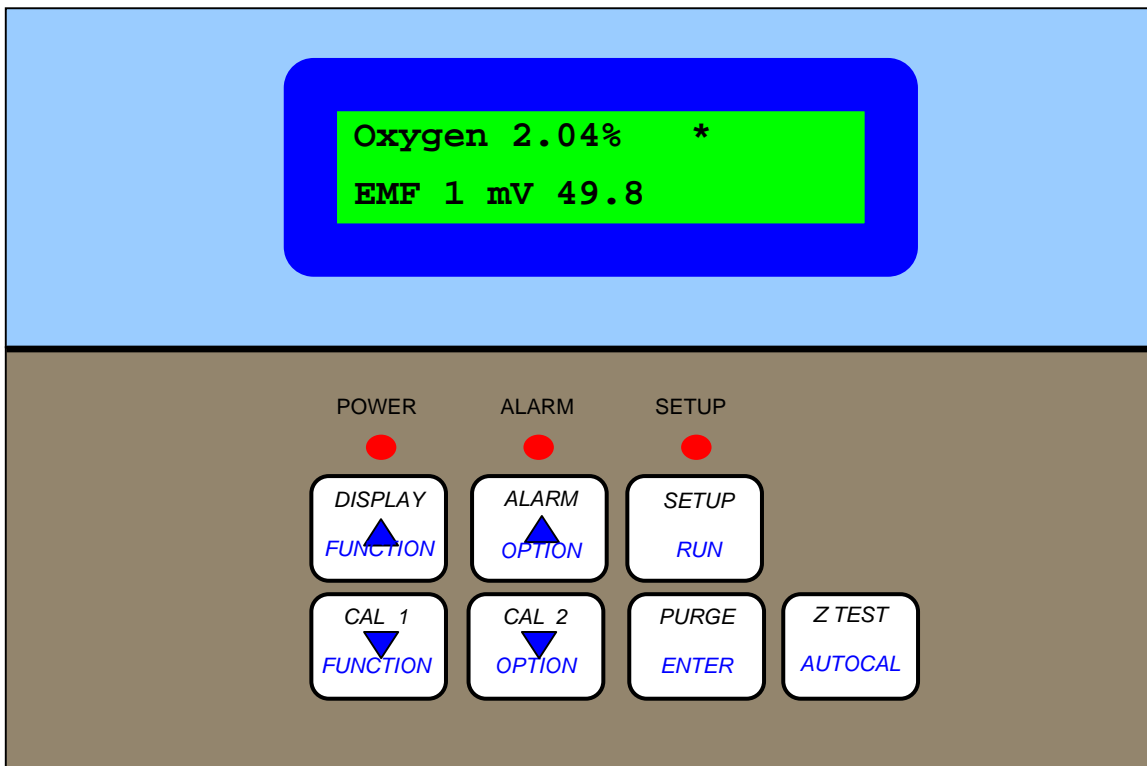

## 5.5 SET-UP FUNCTION DETAILS

**Note:** The \* indicates the default setting after a COLD-START. See Section 6.1

### 1. Number of sensors

#### Options

Select the number of oxygen probes or sensors being used.

- 1 Sensor \*
- 2 Sensors

### 2. Calendar year

### Options

Select the current year for the real time clock / calendar.

The cold start default sets the date and time to the software version date.

### 3. Calendar month

#### Options

Select the current month for the real time clock / calendar.

### 4. Calendar day

#### Options

Select the current day for the real time clock / calendar.

### 5. Real time 8:14 PM clock hour

**Options** Select the current hour for the real time clock. (24 hour format)

### 6. Real time clock minutes

#### Options

Select the current minutes for the real time clock.

### 7. Reference voltage # 1 (about 27.5 mV)

#### Options

Set the value of the reference voltage as read on a 3 1/2 digit multimeter (See Section 6.2 for further details).

27.55 mV \*

### 8. Reference voltage # 2 (about 194 mV)

#### Options

Set the value of the reference voltage as read on a 3 1/2 digit multimeter (See Section 6.2 for further details).

193.60 mV \*

### 9. Reference voltage # 3 (about 1200 mV)

#### Options

Set the value of the reference voltage as read on a 3 1/2 digit multimeter (See Section 6.2 for further details).

1202.00 mV \*

### 10. Reference voltage # 4 (about 2500 mV)

#### Options

Set the value of the reference voltage as read on a 3 1/2 digit multimeter (See Section 6.2 for further details).

2479.00 mV \*

Set-up items 7 to 10 are used to calibrate the A/D of the instrument. This should be done 30 minutes or more after the instrument has been on, approximately once every year. The calibration constants are retained in battery backed memory unless a 'COLD START' is performed. Connect a 3 1/2 digit multimeter negative lead to the test point marked 'C' to the right of the PCB on the inside of the door (labelled 'REF VOLTS'). Measure the four voltages on the test point marked 1 to 4 with the positive lead. Refer to Figure 6.2 in the

## 9060-Zirconia Analyser

9060 manual. Enter the measured values in set-up items 7 to 10. Whenever new values are entered the D/A Section should be re-calibrated, Refer to Section 6.3.

### 11. Set Probe or Sensor 1 Offset

See function 12

### 12. Set Probe or Sensor 2 Offset (When 2 sensors are selected in set-up 1)

A new EMF offset must be entered whenever a new oxygen probe or sensor is installed to calibrate for any offset an individual probe or sensor may have. Each probe or sensor will have an offset value noted on a removable tag. Enter the 'SENSOR OFFSET' value with the same polarity,

eg. if offset value is -1.2 mV. enter -1.2 mV. The typical maximum is +/- 2mV.

To check a probe offset on site, the probe must be sensing air, with reference air, and allowed to settle at the probe operating temperature for 30 minutes. Read the offset in 'RUN' mode in millivolts on the lower line. Offset errors can occur if the sensor does not have some air passing over it. A gentle flow of air in the calibration check port can be provided by a reference air pump or similar.

For heated probes, if the combustion appliance is not operational and the probe heater is interlocked with the 'BURNER ON' signal, the 'BURNER BYPASS' switch should be set to 'ON to power the probe heater after removing the probe from the flue.

#### CAUTION DANGER

Return the 'BURNER BYPASS' switch to normal (off) before installing the probe in the flue.

For unheated probes, the probe sensing tip must be raised to at least 650°C (1200°F) with a portable furnace.

Determine the probe offset in 'RUN' mode. Select 'Sensor EMF' on the lower line. With probe in air, stabilised at temperature for 30 minutes, read the 'Sensor EMF'. Switch back to 'set-up' mode and enter 'Sensor Offset' of equal value and the same polarity.  
eg. If the measured 'SENSOR OFFSET' was -1.2 mV, enter -1.2 mV.

When reading the EMF offset, the flue pressure compensation must be set. If the probe has been removed from the flue, set the flue pressure compensation set up to "Fixed" in set-up 34, and the value to 0 in set-up step 38.

### 13. 4 to 20 mA Calibration Options, Channel #1

Select the calibration method for the 4-20mA output channel #1.

The output channels can be either calibrated by simply pressing the 'AUTO CAL' button, or can be trimmed at both the 4mA and 20mA ends of the scale using an external multimeter.

#### Options:

1. Auto Calibration \*
2. Manual Calibration
3. Set 4mA Trim
4. Set 20mA Trim

If 'AUTO CAL' is selected, the output channel is calibrated when 'Auto Cal' is initiated from the keyboard (See Section 6.3).

If 'MAN CAL' is selected, it is necessary to trim both ends of the 4-20mA output range using the 4mA and 20mA options in this menu item. Selecting 'MAN CAL' inhibits the 'Auto Cal' process of this channel.

Always do the 4mA trim first, and then the 20mA trim. After trimming both ends of the scale, return the 'CALIBRATION OPTIONS' menu option back to 'MAN CAL' (not 'AUTO CAL'), or the calibration factors will be over written by the next 'AUTO CAL'.

For more details on calibrating the output channels, see Section 6.3.

NOTE: The transmitter will only stay in either '4mA TRIM' or '20mA TRIM' modes for 30 minutes before it automatically returns to 'MAN CAL'.

### 14. Calibrate 4mA, Channel #1

This menu item only appears if 'Set 4mA Trim' is selected in Set-up 13.

**Range:** 0 to 25mA, Default is 4.00mA

For full details on the calibration of the 4-20mA output channels, see Section 6.3.

### 15. Calibrate 20mA, Channel #1

This menu item only appears if 'Set 20mA Trim' is selected in Set-up 13.

**Range:** 0 to 25mA, Default is 20.00mA

### 16. 4 to 20 mA Calibration Options, Channel #2

Select the calibration method for the 4-20mA output channel #1.

For more details, see Set-up 13 and Section 6.3.

#### Options:

1. Auto Calibration \*
2. Manual Calibration
3. Set 4mA Trim
11. Set 20mA Trim

### 17. Calibrate 4mA, Channel #2

This menu item only appears if 'Set 4mA Trim' is selected in Set-up 16.

**Range:** 0 to 25mA, Default is 4.00mA

For full details on the calibration of the 4-20mA output channels, see Section 6.3.

### 18. Calibrate 20mA, Channel #2

This menu item only appears if 'Set 20mA Trim' is selected in Set-up 16.

**Range:** 0 to 25mA, Default is 20.00mA

### 19. Enter Service Year

For a new 'DATE OF LAST SERVICE', enter the service 'YEAR'. This can represent the last time the probe or sensor was serviced or the last time the boiler was serviced. It is recommended that probes and sensors be refurbished every two years

### 20. Enter Service Month

Enter the current 'MONTH'.

## 9060-Zirconia Analyser

### 21. Enter Service Day

Enter the current 'DAY' of the month. Altering these values will reset the 'RUN TIME'.

### 22. Sensor 1 Type

### 23. Sensor 2 Type

#### Options:

Model No.	Enter the probe or sensor model number in use
1. 1231/1234 Heated	*Heated Probe or sensor
2. 1232 Unheated	Unheated Probe

### 24. Probe or Sensor 1 Thermocouple Type

See function 25

### 25. Probe or Sensor 2 Thermocouple Type (When 2 sensors are selected in set-up 1) Auxiliary Thermocouple Type (When 1 sensor is selected in set-up 1)

The probe can have either a type K, or R thermocouple as a sensor temperature detector. A 1231 probe or a 1234 sensor will always have a K thermocouple, and a 1232 will usually have an R thermocouple.

#### Options:

1. K	*	Check in the manual Section 1
2. R		for the probe model number.
3. NO T/C		If no TC type is to be used for an Auxiliary use.

#### NOTE

For heated probes the flue (auxiliary) thermocouple is a separate sensor from the oxygen probe and should be mounted near to and upstream from the probe. It is optional. If no thermocouple is required, select option 'NO T/C'. In this case auxiliary temperature read outs will not be operable.

### 26. Transmitter Output Channel 1

Select the type of output required from Channel 1. Linear is the most common output required. The logarithmic output is often used when connected to an analog indicator that will then give an exploded view of the oxygen range near the normal operating level. You can draw your own scale using data in Appendix 3.

#### Options:

1. Linear Oxygen Average (Sensor 1 & 2) (When 2 sensors are selected in set-up 1)
2. Linear oxygen Sensor 1 \* (When 1 sensor is selected in set-up 1)
3. Logarithmic oxygen, sensor 1
4. Reducing oxygen, sensor 1, Range fixed at  $10^{-1}$  to  $10^{-30}$  % oxygen
5. Reducing oxygen, sensor 1, Range fixed at  $10^{+2}$  to  $10^{-4}$  % oxygen (100% to 1ppm)
6. Very low linear oxygen sensor 1, 0 to 0.001 to 2.0% (10 to 20,000ppm)
7. Oxygen deficiency, sensor 1. Range fixed at -5 to +20%.

The reducing output is for special applications requiring extreme reducing conditions eg. ceramic surface treatment.

Linear output spans are adjustable in Set-up step 27. The logarithmic output is fixed at 0.1 to 20 % oxygen and the reducing output is fixed at either  $10^{-1}$  to  $10^{-30}$  % oxygen or  $10^{+2}$  to  $10^{-4}$  % oxygen. If either of the latter three are selected, then set-up 27 will be skipped.

**NOTE:** If output channel is selected for oxygen, and the temperature of sensor 1 or sensor 2 is below 650°C (the display will be flashing “NOT READY”) the 4-20mA output for the associated channel will be set to zero mA.

See set-up 91 for further details.

### 27. Transmitter Span Channel 1

Applicable only to linear outputs. Select transmitter span for output Channel 1. For combustion applications, typical linear spans are 0 to 10 % or 0 to 15 % oxygen. Very low oxygen range is adjustable from 0 to 0.001, to 2.000%.

Default setting is 10.0%.

### 28. Transmitter Output Channel 2

Select transmitter output for output Channel 2.

#### Options:

Sensor EMF 1 \*

1. Logarithmic oxygen, 0.1 to 20 %
2. Oxygen deficiency, sensor 1 (or Sensor 2 if 2 sensors are selected in set-up 1)
3. % carbon dioxide dry
4. Auxiliary (Flue) temperature
5. Linear oxygen % sensor 1 ( or Sensor 2 if 2 sensors are selected in set-up 1)
6.  $1 \times 10^{+2}$  to  $10^{-30}$  % oxygen sensor 1 (or Sensor 2 if 2 sensors are selected in set-up 1), for reducing conditions.
7. Combustibles %
8. Linear Oxygen Average (Sensor 1 & 2) (When 2 sensors are selected in set-up 1)

### 29. Transmitter Zero Channel 2

The output zero and span of Channel 2 is set in set-up steps 29 and 30. Range limits are shown below.

## 9060-Zirconia Analyser

### 30. Transmitter Span Channel 2

Output	Zero Range	Span Range	Default Setting
SENSOR EMF	0 to 1100 mV in 100 mV steps	100 to 1300 mV in 100 mV steps	0 to 100 mV
CARBON DIOXIDE	0 to 10 %	5 to 100 %	0 to 100 %
OXYGEN DEFICIENCY (see Note 3)	+10 to -20 % oxygen deficiency	0 to 20% oxygen excess	-5 to +10 % oxygen
AUX TEMPERATURE	0 to 1300 °C (32 to 2370°F) in 100° steps	100 to 1400 °C (210 to 2550°F) in 100° steps	0 to 1300 °C (32 to 2370°F)
LINEAR OXYGEN	0 to 99%	1 to 100% oxygen	0 to 10% oxygen
LOG OXYGEN (see Note 1)	0.1 % oxygen fixed	20 % oxygen fixed	
REDUCING OXYGEN (see Note 2)	100% to $10^{-10}$ % oxygen in one decade steps, non overlapping	$10^{-3}$ to $10^{-30}$ % oxygen in one decade steps. Min span five decades	100% to $10^{-30}$ %
COMBUSTIBLES %	0 fixed	0.5 to 2.0 %	0 to 2.0 %

#### NOTE

- 1: For log oxygen scale details, Refer to Appendix 3.
- 2: Note that the reducing oxygen span is shown on the display as the exponent only. -1 represents  $10^{-1}$  % oxygen.
- 3: The oxygen deficiency output can be used in the same way as a combustibles analyser to signal the extent of reducing conditions. As an example, if the oxygen deficiency is 3 %, then the burner would need 3 % oxygen to bring it back to stoichiometry.
- 4: Always check that the "\*" is on the RH end of the lower line to lock in the selection before leaving the function.
- 5: If output channel is selected for oxygen, and the temperature of sensor 1 or sensor 2 is below 650°C (the display will be flashing "NOT READY") the 4-20mA output for the associated channel will be set to zero mA. See set-up 91 for further details.

### 31. Top Line Units

The oxygen displayed on the top line can be displayed as percent only or auto-ranging to PPM.

If PPM is selected, the display will still read in percent until the oxygen falls below 0.1% when the display will change to a PPM value, down to 0.1PPM.

#### Options:

Percent \*

PPM

### 32. Centigrade / Fahrenheit Selection

Select whether displays and outputs are to be in ° Celsius or Fahrenheit

#### Options:

1. Celsius (Centigrade) \*
2. Fahrenheit

### 33. Lower Line Display Functions

In the run mode the upper line on the LCD display will always read % oxygen. The lower line can be set to read one or more of the following. Select as many as are required to be displayed by pressing the 'ENTER' button. Those selected will have an asterisk displayed alongside.

#### Options:

1. Average of sensor 1 & sensor 2 oxygen, see Note 3
2. Sensor 2 oxygen , see Note 3
3. Sensor 1 EMF
4. Sensor 2 EMF, see Note 3
5. Sensor 1 temperature
6. Sensor 2 temperature, or Auxiliary temperature if 1 sensor is selected in set-up 1
7. Sensor 1 impedance
8. Sensor 2 impedance, see Note 3
9. Ambient temperature
10. Oxygen deficiency 1, see Note 2
11. Combustibles %, or oxygen deficiency 2 if 2 sensors are selected in set-up 1.
12. CO<sub>2</sub> theoretical maximum
13. Run hours since last service
14. Date of last service

If no lower line options are required then do not enter any. If options already selected are required to be deleted, select the required option and press the 'ENTER' button. The asterisk will be removed.

#### NOTE

1. A flue thermocouple must be connected to Terminals 5 and 6 to obtain a proper reading for option 9 (Refer Section 3.5).
2. The oxygen deficiency display will read 'EXCESS' when the combustion contains excess air.
3. These options will not appear unless two sensors are selected in set up 1.

### 34. Flue Pressure Set-up

If the flue or process gas pressure at the position of the oxygen probe is significantly different from atmospheric pressure, the pressure value should be entered into the transmitter (1 kPa will give an error of about 1% of the oxygen reading).

If the flue pressure is constant, select "Fixed" in this function and select the pressure units and pressure value in set-up 37 and 38.

If the pressure varies, select "Variable Input", and connect a pressure transducer to screw terminals 8 & 9 (see Section 3.26). Set the range of the transducer using a zero and span value set in set-up items 35 and 36.

#### Options:

Fixed \*

Variable Input

### 35. Flue Pressure Zero Input Value

Only available if "Variable Input" is selected in set-up 34.

Set the 4mA level if the pressure transducer measuring the flue or process pressure. The default setting is -1000mb.

#### Limits :

-1000 to +2900mb. The minimum range is 100mb.

### 36. Flue Pressure Span Input Value

Only available if "Variable Input" is selected in set-up 34.

Set the 20mA level if the pressure transducer measuring the flue or process pressure. The default setting is 0mb.

#### Limits :

-900 to +3000mb. The minimum range is 100mb.

### 37. Flue Pressure

Enter flue pressure, eg. 3 mm (0.12") W.G. Only available if "Fixed" is selected in set-up 34.

#### Options:

mm W.G. \*

Kilopascals

Inches W.G.

### 38. Flue Pressure Value

Enter flue pressure e.g. 3 mm (0.12") WG. The default setting is 0. Only available if "Fixed" is selected in set-up 34.

#### Limits :

-3000 to +3000 mm

-3000 to +3000 inches W.G.

-3000 to +3000 kPa

### 39. Single Or Dual Fuel

Enter single or dual fuel. This step and set-up steps 39 to 51 will be skipped if oxygen deficiency, combustibles or maximum carbon dioxide is not selected in set-up steps 28, 33 or 82 for display or output on the 4-20mA channels or the printer port.

A set of default values for the fuel constants are loaded into memory. The fuel constants from Appendix can be entered into the following menu items, or the constants can be tailored to suite any particular fuel.

### Options:

1. Single \*
2. Dual

#### 40. Fuel Number 1 'A' Value

'A' is the heat of combustion of the fuel per gram atom of contained carbon.  
Enter the correct value of 'A' (Refer notes in Appendix 1).

#### 41. Fuel Number 1 'H' Value

'H' is the hydrogen/carbon atom ratio in the fuel.  
Enter the correct value of 'H' (Refer notes in Appendix 1).

#### 42. Fuel Number 1 'O' Value

'O' is the oxygen/carbon atom ratio in the fuel.  
Enter the correct value of 'O' (Refer notes in Appendix 1).

#### 43. Fuel Number 1 'N' Value

'N' is the nitrogen/carbon atom ratio in the fuel.  
Enter the correct value of 'N' (Refer notes in Appendix 1).

#### 44. Fuel Number 1 'S' Value

'S' is the sulphur/carbon atom ratio in the fuel.  
Enter the correct value of 'S' (Refer notes in Appendix 1).

#### 45. Fuel Number 1 'M' Value

'M' is the ratio of water molecules to carbon atoms in the fuel. Enter the correct value of 'M' (Refer notes in Appendix 1). For single fuel applications the next set-up step will be 52, for dual fuel the next step is 46.

#### 46. Fuel Number 2 'A' Value

'A' is the heat of combustion of the fuel per gram atom of contained carbon.  
Enter the correct value of 'A' (Refer notes in Appendix 1).

#### 47. Fuel Number 2 'H' Value

'H' is the hydrogen/carbon atom ratio in the fuel.  
Enter the correct value of 'H' (Refer notes in Appendix 1).

#### 48. Fuel Number 2 'O' Value

'O' is the oxygen/carbon atom ratio in the fuel.  
Enter the correct value of 'O' (Refer notes in Appendix 1).

#### 49. Fuel Number 2 'N' Value

'N' is the nitrogen/carbon atom ratio in the fuel.  
Enter the correct value of 'N' (Refer notes in Appendix 1).

#### 50. Fuel Number 2 'S' Value

'S' is the sulphur/carbon atom ratio in the fuel.  
Enter the correct value of 'S' (Refer notes in Appendix 1).

#### 51. Fuel Number 2 'M' Value

'M' is the ratio of water molecules to carbon atoms in the fuel.

Enter the correct value of 'M' (Refer notes in Appendix 1).

### 52. Purge / Cal Time

Set the first purge to occur at the correct time-of-day. If purging is not required but on-line auto gas calibration check is required, enter a time-of-day value suitable for the auto calibration checks. Cal Gas 1 will be tested ten minutes after the purge/cal time and Cal Gas 2, 20 minutes after. If neither purge nor auto calibration check is required, ignore this time setting.

**Range:** 0 to 23 hours in one hour steps. The default time is 12 noon.

### 53. Automatic Purge

For some oil and coal fired plant, probe filters are necessary and should be back-purged with sufficient frequency to avoid blocked filters. The outputs will be frozen during purging. If no purge is required, set-up steps 54, 55 and 56 will be skipped.

#### Options:

None	*
Purge	
Auto Offset	++
Key Auto Offset	++

++ Note: If 'Calibrate' is selected in set-up step 92 these two additional options will be available.

If Auto Offset is selected, set-up steps 54 to 56 will be available. By using these steps the transmitter can be configured to make small corrections to the probe offset automatically. The offset correction is limited to +/- 3mV.

If Auto Offset is selected set-up 54 and 55 allow the automatic time periods to be set.

If Key Auto Offset is selected the offset correction can be started from the keypad (PURGE).

### 54. Time Between Purges

Set the time between purges eg. a two hourly purge or a 100 hourly purge.

#### Range:

1 to 199 hours. Default setting is 24 hours.

### 55. Purge Duration

Set up purge duration to a number between three and ten seconds. The filter is actually purged in less than one second, but three seconds are required for the purge flow switch to check that the filter is not blocked.

#### Range:

0 to 10 seconds. Default setting is 10 seconds.

### 56. Purge Freeze Time

After the purge period the transmitter output will remain fixed (frozen) for an adjustable period to allow the probe reading to return to the correct process level and avoid output 'bumps'. The freeze period time required will depend on the probe response time and thus its design, and whether it has a filter or not.

To determine the required freeze time, manually perform a purge while the plant is in operation and note the time required for the reading to return to the correct process level within approximately 0.5 % oxygen.

#### Range:

10 to 1000 seconds in ten second steps. Default setting is 60 seconds.

### 57. Number Of Cal Gases

Select the number of calibration or checking gases to 0, 1 or 2. For example, one gas could be air (20.9 % oxygen) and the other 2 % oxygen

#### Options:

No Gas Check \*

Single Gas Check

Two Gas Check

Auto Gas Calibrate ++

Key Gas Calibrate ++

During the timed calibration check periods the transmitter outputs will be frozen and the transmitter will alarm if readings are not within the accuracy limits sets in set-up steps 59 and 60. If auto gas checking is not required enter 'No Gas Check' and the transmitter will step to set-up 70.

++ Note: If 'Calibrate' is selected in set-up step 92 these two additional options will be available.

If Auto Gas Calibrate is selected, set-up steps 58 to 63 (and 64 to 69 for 2 probes) will be available. By using these steps the transmitter can be configured to make small corrections to the calibration automatically. Select the oxygen content in set-up 58 (64) and the time periods in set-up steps 61 to 63 (67 to 69).

If Key Gas Calibrate is selected the automatic correction can be instigated from the keypad (CAL1 and CAL2).

### 58. Oxygen Content Of Cal Gas 1

Enter value of Cal Gas 1 (to one decimal point).

#### Range:

0.1 to 20.9 % oxygen. Default setting is 8.0 % oxygen.

### 59. Maximum Acceptable Positive Error Gas 1

Set the maximum positive error above which the 'Gas 1 Cal Error' alarm will be initiated after the timed period set in set-up step 55.

#### Range:

0.1 to 3.0 % oxygen. The default setting is 0.5 % oxygen.

### 60. Maximum Acceptable Negative Error Gas 1

Set the maximum negative error below which the 'Gas 1 Cal Error' alarm will be initiated after the timed period set in set-up step 55.

#### Range:

0.1 to 3.0 % oxygen. The default setting is 0.2 % oxygen.

### 61. Period Between Gas 1 Autocal

Set the number of hours between autocal Gas 1. A typical time would be 24 or 168 hours. (Daily or weekly).

**Range:** 1 to 1999 hours. The default setting is 1 hour.

### 62. Duration Of Autocal Gas 1

Set the number of seconds that the autocal gas solenoid will be open. At the end of this period, if the oxygen level measured is not within the limits set for Cal Gas 2, an 'Gas 2 Cal Error' will initiate. To determine the minimum time required for a particular length or design of probe to settle, manually admit cal gas while observing the oxygen reading in 'RUN' mode. Typical minimum times vary from 15 seconds to 90 seconds, depending on the probe length and gas plumbing arrangement. If there is a filter fitted to the oxygen probe, the calibration check reading will be much closer to the actual gas value.

#### Range:

0 to 90 seconds. The default setting is 10 seconds.

### 63. Freeze Time Gas 1

After the Cal Gas 1 period, the transmitter output will remain fixed (frozen) for an adjustable period to allow the probe reading to return to the correct process level and avoid output 'bumps'. The freeze period time required will depend on the probe response time, and whether or not it has a filter fitted.

#### Range:

0 to 100 seconds in one second steps. The default setting is 30 seconds. To determine the required freeze time, manually perform a calibration check with Gas 1 while the plant is in operation and note the time required for the reading to return to the correct process level within approximately 0.5 % oxygen.

If the freeze time is set to zero the 4-20mA outputs will be updated during the purge time AND the freeze time. (ie. the outputs will NOT be frozen) This mode will satisfy Environmental Protection Authorities if required.

### 64 to 69. Cal Gas 2 Parameters

Enter the same requirements for Cal Gas 2 as per set-up steps 58 to 63 for Cal Gas 1. Cal Gas 2 could typically be 2 % oxygen in nitrogen.

### 70. Process Alarm Enable

If process alarms are not required, 'NO' can be selected. There will not be any process related alarms generated, and all process alarms will be cancelled, if 'NO' is selected. The process alarms are High oxygen, Low oxygen, Oxygen deviation, and Very low oxygen.

#### Options:

Yes

No \*

### 71. High Oxygen Alarm

Set the operating point for the high oxygen alarm relay.

#### Range:

0.1 –30.0% oxygen. The default setting is 10.0 % oxygen.

### 72. High Oxygen Delay

Typically set at 30 seconds. This delay is to avoid nuisance alarms when the burner is undergoing transitions in firing rate that can cause it to deviate from the oxygen set point, but recover quickly.

**Range:**

0–200 seconds. The default setting is 60 seconds.

### 73. Low Oxygen Alarm

Set the operating point for the low oxygen alarm relay. Typically set at 2.0% oxygen, depending on the burner, it can be used as a safety warning.

**Range:**

0.1 –21% oxygen. The default setting is 2.5 % oxygen.

### 74. Low Oxygen Delay

Typically set at 30 seconds. This delay is to avoid nuisance alarms when the burner is undergoing transitions in firing rate that can cause it to deviate from the oxygen set point, but recover quickly.

**Range:**

0–200 seconds. The default setting is 10 seconds.

### 75. Oxygen Deviation Alarm (Only available if '2 sensors' is selected in set-up 1)

If the difference between 2 sensors running on a transmitter is greater than the limit set here, the alarm will be triggered.

This alarm could be used to give an on-line warning of a problem in one of the sensors.

**Range:**

0.1 –21% oxygen. The default setting is 2.0 % oxygen.

### 76. Oxygen Deviation Alarm Delay (Only available if '2 sensors' is selected in set-up 1)

A 30 second delay in the activation of this alarm will usually be ample to cover any deviation due to short-term stratification differences between the two sensors.

**Range:**

0–200 seconds. The default setting is 30 seconds.

### 77. Very Low Oxygen Alarm

Set the operating point for the very low oxygen alarm relay, typically 0.5% oxygen. This limit can be used as a shut down on a boiler as the normal operating level should never be this low.

**Range:**

0.001 –2.000% oxygen. The default setting is 0.500 % oxygen.

### 78. Very Low Oxygen Delay

Set the very low oxygen alarm delay to the smallest possible period to avoid nuisance alarms/shut-downs, but still maintain the fastest response to a fuel rich atmosphere

**Range:**

0–200 seconds. The default setting is 2 seconds.

### 79. Alarm Relay #2

Any or all of the following alarm functions may be used to activate the alarm relay. They may be selected or de-selected using the 'ENTER' buttons as in set-up step 33.

**Options :**

1. Low oxygen

2. High oxygen
3. Very low oxygen
4. Oxygen deviation between sensor 1 and sensor 2, (if sensor 2 is selected)
5. Gas 1 Check Error
6. Gas 2 Check Error
7. No Gas calibration (calibration not successful)
8. Probe or sensor under temperature
9. Calibration check in progress
10. Probe purge in progress

### 80. Alarm Relay #3

Alarm relay #3 has the same functions available as alarm relay #2. See SET-UP 79.

### 81. Alarm Relay #4

Alarm relay #4 has the same functions available as alarm relay #2. See SET-UP 79.

In addition an alarm horn function is also available.

If 'Horn' is selected it will override any other selections. A relay selected as a 'Horn' driver will have the relay contacts open circuit if there is an unaccepted alarm, and closed when a new alarm occurs.

### 82. Data To Print

Any or all of the following values may be printed on a printer or computer connected to port 2. They may be selected or de-selected using the 'ENTER' buttons as in set-up step 33.

The log period follows in set-up step 83.

A sample of a printout is contained in Appendix 4.

**NOTE:** If a MODBUS™ address other than zero is selected in Set up 88, the data log function will be disabled. For further details, see Set up 88.

RS232C protocol is :

Data word length	Eight bits
Stop bits	One
Parity	None

Oxygen is always printed (average if 2 sensors are selected), plus any of the following

#### Options :

1. Sensor 1 oxygen
2. Sensor 2 oxygen
3. Sensor 1 EMF
4. Sensor 2 EMF
5. Sensor 1 temperature
6. Sensor 2 temperature, or Auxiliary temperature if 1 sensor is selected in Set up 1
7. Sensor 1 impedance
8. Sensor 2 impedance
9. Ambient temperature
10. Oxygen deficiency 1
11. Combustibles %, or oxygen deficiency 2 if 2 sensors are selected in set up 1.
12. CO<sub>2</sub> theoretical maximum
13. Run hours since last service
14. Date of last service

### 83. Print Log Period

Select the time interval between data print outs on the printer.

When the print period is selected below “1 minute”, the selection will automatically switch to “seconds”. The time can then be selected up to 120 seconds. Above 120 seconds the time will switch automatically back to minutes.

NOTE: The print log could be up 2 seconds after the expected time.

#### Range:

5 to 120 seconds, 1 to 2000 minutes

### 84. Printer Baud Rate

Select the correct BAUD rate for data to be transmitted out of the port to the printer.

#### Options:

300

1200

2400

4800

9600

\*

### 85. Reference Air Selection

The reference air supply for the oxygen sensor is normally supplied from the transmitter. If the internal pump is not being used, ‘External’ must be selected to stop the ‘Ref Pump Fail’ alarm. If an external air supply that has a known relative humidity, select ‘Instrument Air’.

This will allow the relative humidity level to be entered in set-up 86.

Less than half a litre per minute provides sufficient reference air for any sensor.

**Note:** If ‘Internal’ is selected, and a reference airflow sensor is connected to CN8 on the 1630-2 (terminal) PCB, the pump is cycled on and off within a minute.

#### Options:

Internal

\*

External

Instrument air

### 86. Reference Air Relative Humidity

This selection will only appear if ‘Instrument Air’ is selected in set-up 85.

If the reference air is being supplied from an instrument air supply, the relative humidity will be different from the ambient air being measured within the transmitter. In this case set the set the RH to the RH of the air supply. As a guide, the RH of a compressor driven air supply is about 10%.

#### Range:

1-100%

### 87. Damping Factor

Each time a new reading is read from the oxygen probe or sensor, the new reading is averaged with the last readings taken, before the new average is either displayed on the LCD, or sent to the 4 to 20 mA output. The number of readings that are averaged together is adjustable with this function. A value of five for example, means that the new reading from the probe or sensor and the previous four readings are averaged together before being displayed. A value of one entered here will mean that every new reading from the probe or sensor will be sent to the display unaltered.

The smoothing of the oxygen signal is an exponential function. If a factor of 5 is used, a step change of input signal will take about 5 seconds to reach 63% of the change on the output/display.

**Range**

1 to 20. Default setting is 5.

### 88. MODBUS™ Address

This function is used when networking of one or more transmitters back to a master computer or data acquisition system is required. For more details on the functions of the MODBUS™ see Section 2.12, and Appendix 6.

The valid range of MODBUS™ addresses is from 1 to 31. Any transmitter with zero selected as the MODBUS™ address will have the MODBUS™ disabled, and the data log function enabled.

For the connection details, see Section 3.15.

**NOTE:** If the MODBUS™ address is changed, the transmitter must be turned off and back on for the address change to take effect.

**Range:**

0-31 Default setting is 0.

## Extended Menus

---

### 89. Reference Air Pump Cycle

The reference air pump will normally run all the time. However, if the inside case temperature is greater than 35°C the pump will turn off for 30 seconds every minute to reduce the case temperature and extend the life of the pump.

Where the ambient temperature is always greater than 35°C, the life of the pump can be further extended by reducing the pump on time. This function allows the user to set the on time of the pump over a 10 minute cycle.

**Range:**

1-10 Default setting is 10 (Always on)

Temperature >35°C Burst (Always on unless case >35°C) \*

### 90. Low Oxygen Calibration Factor, Sensor #1

The Teledyne zirconia oxygen sensors only require the sensor offset to be set. This corrects the oxygen reading for any sensor offset at the 20.9% level (See Set-up 11 & 12 for details). After setting the offset oxygen readings other than 20.9% will also be within the rated specification for nearly all applications.

To allow zirconia probes made by other manufacturers to also be used on the Teledyne transmitter, a correction factor can be entered to allow for oxygen reading much smaller and much larger than 20.9% to be fine tuned.

For complete details of how to set the “Low Oxygen Calibration” see Section 2.9.

**Range**

90 to 110. Default setting is 100.

### 91. Low Oxygen Calibration Factor, Sensor #2

Follow the same procedure outlined in set-up 90 for calibration of sensor #2.

### 92. Gas Calibration / Checking

The Teledyne oxygen sensor is an extremely stable sensor. However if it is required to make a fine adjustment to the sensor offset voltage or the scaling at a specific oxygen concentration, this can be done using this function.

If Check is selected, the set-up steps 53 to 69 operate as described on the previous pages.

During the automatic gas calibration a mid gas calibration factor is saved in the next function, set-up 93 (and 94).

If Calibrate is selected, there will be addition options in set-up #53 and 57.

#### Options:

Calibrate

Check \*

### 93. Oxygen Mid Point Calibration factor 1

During the automatic gas calibration described in set-up 92, a mid gas calibration factor is calculated and saved in this function for probe #1. This factor is limited to less than 0.5% oxygen if the calibration gas (set in set-up 58 and 64) is above 2.0% or 0.2% if the calibration gas is below 2.0% oxygen.

#### Range

-0.5 to +0.5% oxygen. Default setting is 0.0%.

### 94. Oxygen Mid Point Calibration factor 2

This factor is used in the same way Mid Point Calibration Factor #1 but is used for probe #2 if it is fitted.

### 95. Enable 4-20 Limit

The zirconia oxygen sensor will not give a valid reading when it is below 650°C. So that an invalid sensor signal is not used when the sensor is below 650°C the output 4-20mA channels are taken to 0mA.

If the output channels are required to reflect the oxygen reading even if the sensor is below 650°C, this option should be set to NO.

#### Options:

Yes \*

No

### 96. SSR Fail Alarm loops

The 9060 Analyser monitors the solid state relays that are used to control the heater in the probe. If the SSR fails the probe temperature will loop between 680°C and 800°C. When these variations are detected, the transmitter raise a "SSR Fail" alarm and turn off the heaters when the number of loops exceeds the number set in this function.

A faulty SSR may be bypassed by using the SSR for the second probe or the gas solenoids if these are not being used. See set-up 99 for more information.

#### Range

0 (Disabled) to 9. Default setting is 3.

### 97. Heater SSRs swapping

If a faulty SSR is detected with the “SSR Fail” alarm this function can be used to swap the SSR’s to get the transmitter working.

“Swap SSR 1<->2” will swap the two heater SSR’s. Use this option if the SSR on heater #1 fails and there is no probe connected to heater #2. The heater for probe #1 will have to be plugged into the Heater #2 socket after this is changed.

“Swap Cal SSRs” will swap the two heater SSR’s for the two cal gas solenoid SSR’s. Use this option if the transmitter is being used to control two probes but the calibration gas solenoids are not being used.

#### Options:

Normal \*

Swap SSR 1<->2

Swap Cal SSRs

# MAINTENANCE

## 6

SECTION  
NUMBER

### TRANSMITTER MAINTENANCE

- 6.1 COLD START
- 6.2 A/D CALIBRATION
- 6.3 D/A CALIBRATION
- 6.4 PUMP REPLACEMENT
- 6.5 BACK-UP BATTERY REPLACEMENT
- 6.6 ELECTRONIC REPAIRS

### PROBE MAINTENANCE

- 6.7 INSTALLING A NEW PROBE OR SENSOR
- 6.9 TEST EQUIPMENT REQUIRED
- 6.10 TESTING A PROBE OR SENSOR
- 6.11 PROBE OR SENSOR THERMOCOUPLE
- 6.12 HEATER FAILURE
- 6.13 FILTER BLOCKAGE

## TRANSMITTER MAINTENANCE

### 6.1 COLD START

A 'COLD START' will reset all 'Set-up' mode entries to their factory default values. 'COLD START' will show on the display for a second prior to a microprocessor initialising sequence, which takes about seven seconds.

After a 'COLD START', it is necessary to set all new variables in the 'SET-UP' mode, including calibration voltages and time and date.

#### To initiate a 'COLD START' -

Turn the mains power off

Remove the 'COLD START LINK' (this is located on the door PCB, next to the keyboard lock switch, behind the shield)

Turn the mains power on. The message "Cold Start....." will be displayed.

Leave the LINK off until the message "Replace c/s Link" is displayed. Replace the LINK.

The date and version number of the software will be displayed.

A 'WARM START', which is performed by applying power with the COLD START LINK in its place, will retain all data previously entered in the Set-up mode.

### 6.2 A/D CALIBRATION

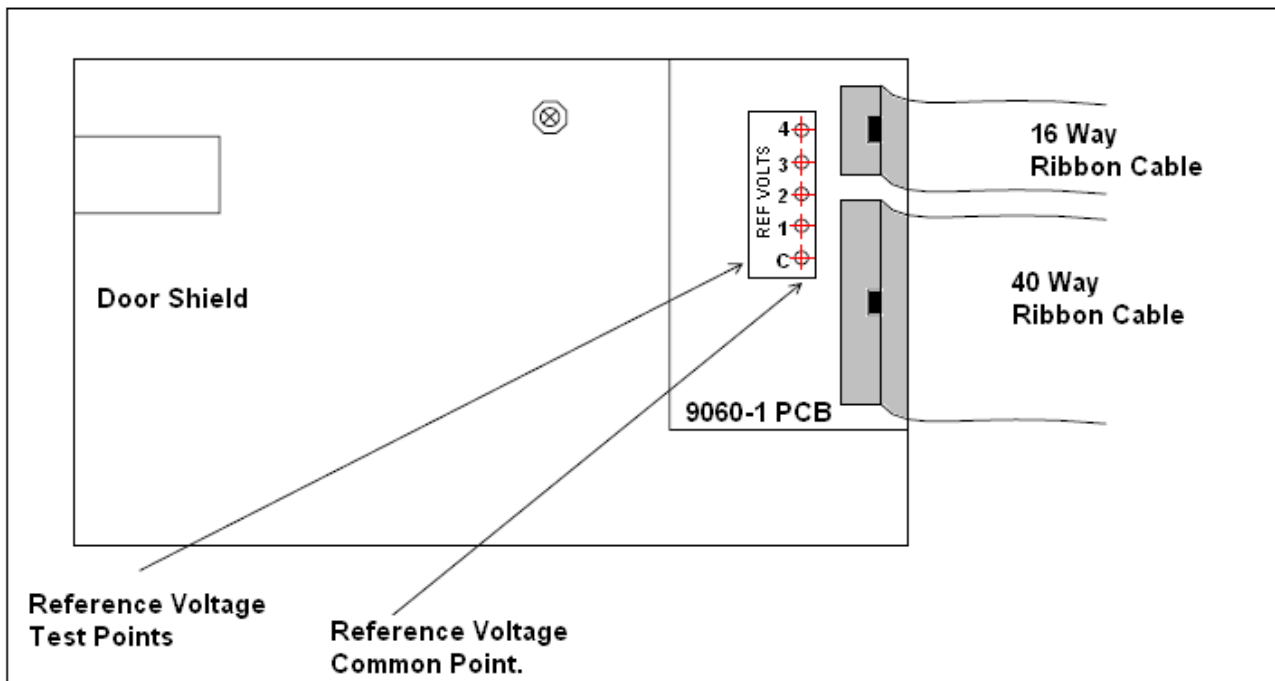

Location of Calibration Test Points

The transmitter maintains its accuracy over a very long period by continuously checking itself against internal stabilised references. The only calibration required is to set the actual values of these references into battery backed memory. The transmitter will read these references every minute and update its zero and span correction factors. See Section 5.5.7 to 10.

These references should be checked every 12 months. An AUTOCAL of the analog output section should always be performed if these references are altered. See Section 6.3.

### 6.3 D/A (4-20mA OUTPUT CHANNELS) CALIBRATION

The calibration can either be done using the 'Auto Cal' or 'Manual Cal'.

#### **Auto Cal**

The 'Auto Cal' mode is selected in set-up 13 (and 16 for channel 2).

The transmitter will automatically divert the output back to the input, measure the offset and span, and record the calibration factors for each channel.

If either of the channels are selected to be calibrated manually, an 'Auto Cal' will not change the factors.

#### **Manual Cal**

The 'Manual Cal' mode is selected in set-up 13 (and 16).

**Set the 4mA calibration first and then the 20mA calibration.**

1. Select 'Set 4mA Trim' in set-up 13 (or 16).
2. Return to RUN mode.
3. Measure the output on the channel to be calibrated with a digital multimeter. If the current is not exactly 4.00mA, return to set-up mode and change the 4mA calibration factor in set-up 14 (or 17).
4. Re-measure the current while back in RUN mode until the current is within 3.9 to 4.1mA.
5. Return to set-up mode and select 'Manual Cal' in set-up 13 (or 16).

**Set the 20mA calibration factor.**

6. Select 'Set 20mA Trim' in set-up 13 (or 16).
7. Return to RUN mode.
8. Measure the output on the channel to be calibrated with a digital multimeter. If the current is not exactly 20.00mA, return to set-up mode and change the 20mA calibration factor in set-up 15 (or 18).
9. Re-measure the current while back in RUN mode until the current is within 19.9 to 20.1mA.
10. Return to set-up mode and select 'Manual Cal' in set-up 13 (or 16).

This calibration is now saved in battery backed memory until

The factors are changed in the manual calibration

The transmitter is forced into a COLD-START (see section 6.1)

The calibration mode in set-up 13 (or 16) is changed to Auto Cal and an Auto Cal is initiated.

**NOTE:** The 4mA or the 20mA trim mode will only be held on the output channels for 30 minutes before automatically returning to 'Manual Cal' mode in set-up 13 (or 16).

### 6.4 PUMP REPLACEMENT

The reference air pump is mounted on the 1630-2 PCB in the base of the transmitter. The operation of the pump is monitored by the transmitter and alarms will be shown if a fault occurs. ("Pump Fail" alarm)

To replace the pump, unplug all the field wiring terminals. ie. Probe connectors, power connector etc.

The nuts for the pump screws are captive into the PCB, enabling the pump to be removed WITHOUT removing the PCB. The pump wires can be unplugged.

### 6.5 BACK-UP BATTERY REPLACEMENT

The back-up battery is contained within the battery-like real time clock/memory module, plugged into socket M2. It is rated for an average service life of greater than ten years. The module is not re-chargeable and should be replaced every three years in a stored transmitter with power off or every eight years with transmitters that have had the power on. The memory module must be purchased from Teledyne or an agent of Teledyne. After replacing the battery, re-enter all set-up mode functions.

### 6.6 ELECTRONIC REPAIRS

Electronic schematics are included in Appendix 5. A competent electronic technician could perform troubleshooting with these schematics, aided by the transmitter self-diagnostic alarms. It is recommended that service be performed on a changeover circuit board basis. A fast turn-around or replacement service is available from Teledyne or accredited service agents. Other service aids, including a test EPROM firmware package and probe input simulator are also available.

There are 3 fuses on the 1630-2 (terminal) PCB. FS1 and FS2 are M205 3Amp (or 3.15Amp) fast blow and are in the input power active and neutral lines. FS3 is a PCB mounted 375mA fuse and is in series with the power transformer primary winding.

If any of these fuses are blown the transmitter display will be blank.

### 6.7 INSTALLING A NEW PROBE OR SENSOR

Whenever a new oxygen probe or sensor is installed, the millivolt offset value should be entered. To achieve this refer to set-up 11 (and 12 for the second sensor).

The probe or sensor offset is noted on a tag or label attached to probe or sensor. To check an offset on site, the probe or sensor must be sensing air with reference air connected and allowed to settle at the operating temperature for 30 minutes. Read the offset in 'RUN' mode in millivolts on the lower line. Offset errors can occur if the sensor does not have some air passing over it. A gentle flow of air in the calibration check port can be provided by a reference air pump or similar. If a probe is in a process with the process running, the air purge on the sensing side of the oxygen sensor will only be successful if the probe has a filter or small sensing hole. Probes with open sensing ends or with large sensing holes allow the process gas to mix with the calibration gas, giving a false reading.

For heated probes or sensors, if the combustion appliance is not operational and the probe or sensor heater is interlocked with the 'FUEL ON' signal, the 'BURNER BYPASS' switch should be set to 'BYPASS' to power the probe or sensor heater after removing the probe or sensor from the flue. For unheated probes, the sensing tip must be raised to at least 650°C (1200°F) with a portable furnace.

#### **CAUTION DANGER**

Return the 'BURNER BYPASS' switch to normal (off) before installing the probe or sensor in the flue.

### 6.8 TEST EQUIPMENT REQUIRED

All measurements are simplified if a transmitter is connected to the probe or sensor. Readings can then be easily taken of probe or sensor impedance, EMF, temperature and percent oxygen. The transmitter also provides proper heater control for heated probes or sensors.

The following tests are described using readily available workshop equipment where a transmitter is not available. If a transmitter is available the same test procedures will apply. First check all alarms on the transmitter, allowing time for the probe or sensor to heat up after switch on.

An instrument to measure probe or sensor EMF and temperature is required. A 3 1/2 or 4 1/2 digit multimeter will perform both measurements.

A separate temperature indicator to suit the probe or sensor thermocouple type is also useful, although not necessary.

A reference air pump is required and a cylinder of calibration check gas e.g. 2 % oxygen in nitrogen. The cylinder should have a pressure and flow regulator. Both of these are inexpensive devices available from gas supply companies. The calibration check gas should be chromatograph tested to an accuracy of 0.1 % oxygen.

### TEST EQUIPMENT FOR UNHEATED PROBES

A small test furnace capable of raising the probe tip temperature to over 700°C (1300°F) is required. The furnace should have a uniform temperature for about 50 mm (2") either side of the sensor tip.

### TEST EQUIPMENT FOR HEATED PROBES OR SENSORS

If a 9060 Analyser is available at the test location then no other equipment will be required. If not, then a controllable power source for the heater is required. A Variac (variable transformer), set to approximately 80 volts will regulate the probe or sensor temperature to over 700°C (1300°F).

### 6.9 TESTING A PROBE OR SENSOR

With the probe or sensor heated to over 700°C (1300°F), either from a small test furnace or its own internal heater, connect a digital multimeter to the probe or sensor electrode conductors. Connect the multimeter positive to the internal electrode conductor. Connect reference air to and apply a gentle purge of air to the probe calibration check port. Reference airflow should be 50 to 500 cc/minute (6 to 60 scfm). The multimeter should read zero millivolts  $\pm$  two millivolts. If not, then there is a problem with the probe electrodes and the sensor needs refurbishing. Normally a faulty probe electrode is indicated with a high source impedance. 1234 sensors do not require reference air but a gentle flow of air should be admitted into the sample connection.

To test the source impedance, set the multimeter to read ohms and take a measurement, within a couple of seconds, of the probe or sensor impedance. Reverse the multimeter and repeat the reading. Take the average of the two readings for an approximate

## 9060-Zirconia Analyser

measurement of impedance. If the impedance is above 10k $\Omega$ , then the probe or sensor needs to be replaced. The probe or sensor must be over 700°C (1300°F) or above for this measurement. The reason that impedance measurements need to be performed quickly, is that the zirconia sensor polarises with the DC voltage from the multimeter across it.

If the probe or sensor tests reveal less than 2 mV offset and a good impedance reading, the next step is to apply a calibration check gas. The calibration check gas should be inserted in the calibration check port. With the calibration check gas flowing, the probe or sensor should develop an EMF according to the tables in Appendix 2. If the EMF reading is low then there may be insufficient calibration check gas flow. Increase the calibration check gas until the reading is correct. An excessive calibration check gas flow will cause cooling on one surface of the sensor, giving temperature differential errors on the sensor.

As an alternative, using the reference air port, the calibration check gas can be inserted into the inside of a probe sensor. This requires a lower flow rate, and thus lower usage of calibration check gas. The flow rate should be similar to that of the reference air, which should be removed for internal calibration check. The probe or sensor EMF reading will be identical but negative in polarity. A small flow of air should be flowing over the outside of the sensor, when testing in this way.

Occasionally, a sensor can develop offset with a polluted electrode caused by contaminants in the flue gas stream. In this case the impedance may be OK but the output incorrect. This phenomenon is rare.

### 6.10 PROBE OR SENSOR THERMOCOUPLE

Although some unheated probes are specified without a thermocouple, most probes, both heated and unheated, have an integral thermocouple which is fitted in to the four bore insulator. The transmitter has an alarm function that will advise the operator of an open circuit thermocouple, however bench testing can be performed by simply measuring the thermocouple continuity.

### 6.11 HEATER FAILURE

For heated probe or sensors, a heater failure will cause a 'SENSOR UNDER TEMP' or 'HEATER FAIL' alarm. Heaters can be tested with a continuity test. The heater impedance should be approximately 100 $\Omega$ . Should the heater be open or short-circuited, replace the probe or sensor.

### 6.12 FILTER BLOCKAGE

For oxygen probes with filters in installations with entrained solids in the flue gas, it is sometimes necessary to replace the filter. Filters are normally cleared with back purging. However fine fly ash or other particles can ultimately completely block a filter necessitating filter replacement. A new probe filter can be fitted.



# APPENDICES

1. CONSTITUENT VALUES FOR VARIOUS FUELS
2. PROBE OR SENSOR EMF TABLES
3. % OXYGEN SCALE TO LOGARITHMIC
4. SAMPLE LOG PRINT OUT
5. CIRCUIT SCHEMATICS
6. MODBUS™ REGISTER MAP & APPLICATION NOTES

# APPENDIX 1

## CONSTITUENT VALUES FOR FUELS

If the transmitter is set up to have readout or output of combustibles or maximum carbon dioxide, then the fuel constituents must be entered. Any or all of the variables can be modified and entered in set-up steps 39 to 45 and 46 to 51. (Refer to Section 5.5). Your fuel supplier or chemist should be able to give you all these values.

- A** is the heat of combustion of the fuel per gram atom of contained carbon.
- H** is the H/C atom ratio in the fuel.
- O** is the O/C atom ratio in the fuel.
- N** is the N/C atom ratio in the fuel.
- S** is the S/C atom ratio in the fuel.
- M** is the ratio of H<sub>2</sub>O molecules to C atoms in the fuel

## 9060-Zirconia Analyser

FUEL	A	H	O	N	S	M
Blast furnace gas	50.55	0.08	1.30	3.08	b	a
Coke oven gas	256.88	5.60	0.25	0.23	b	a
Producer gas	101.98	1.18	1.02	2.90	b	a
Natural gas	209.90	3.86	0	0.10	0	0
Propane, natural	176.40	2.69	0	0	0	0
Butane, refinery	166.10	2.34	0	0	0	0
Methanol	172.59	3.97	1.00	—	—	—
Gasoline, motor	157.58	2.01	0	0	0	0
No 1 Distillate oil	149.65	1.83	0	—	0	—
No 2 Distillate oil	145.18	1.71	—	—	0	—
No 4 Fuel oil	145.54	1.60	—	—	0.01	0
No 5 Residual oil	142.25	1.44	—	0	0	0
No 6 Residual oil	136.52	1.25	0.01	0	0	0
Wood, non-resinous	110.91	2.26	1.07	0	0	c
Coal, bituminous	116.88	0.74	0.05	0	0	0.03
Coal, anthracite	104.98	0.35	0.05	0	0.01	0.04
Coke	99.63	0.11	0.01	0.01	0	0.01

- a.** The moisture level varies depending on the process details.  
The calculated values assume  $M = 0$ .
- b.** The sulphur level varies depending on the process details.  
The calculated values assume  $S = 0$ .
- c.** Variable.

Values calculated from the North American Combustion Handbook, Tables 2.1a and 2.1b.

# APPENDIX 2

## PROBE OR SENSOR EMF TABLES

## ZIRCONIA OXYGEN SENSOR OUTPUT (mV) PROBE TYPE 1231, SENSOR TYPE 1234

**% OXYGEN** **mV at 720°C (1320°F)**

---

21.0	0.00
20.5	0.46
20.0	0.99
19.5	1.53
19.0	2.09
18.5	2.66
18.0	3.25
17.5	3.85
17.0	4.47
16.5	5.11
16.0	5.77
15.5	6.45
15.0	7.15
14.5	7.87
14.0	8.62
13.5	9.40
13.0	10.21
12.5	11.05
12.0	11.92
11.5	12.83
11.0	13.78
10.5	14.78
10.0	15.82
9.5	16.92
9.0	18.08
8.5	19.30
8.0	20.60
7.5	21.98
7.0	23.45
6.5	25.04
6.0	26.75
5.5	28.61
5.0	30.65
4.5	32.90
4.0	35.42
3.5	38.28
3.0	41.58
2.5	45.48
2.0	50.25
1.5	56.41
1.0	65.08
0.5	79.91
0.2	99.51

---

**'K' TC mV      29.212 at 720°C (1320°F)**

These tables are based on the Nernst equation:

Sensor e.m.f. =  $0.02154 \times T \times \ln \times 20.95 / \% \text{ oxygen}$ , where  $T = ^\circ \text{K} (^{\circ} \text{C} + 273)$ , e.m.f. is in mV's

**ZIRCONIA OXYGEN PROBE OUTPUT (mV)**  
**PROBE TYPE 1232**

% O <sub>2</sub>	TEMPERATURE (°C (°F))								
	600 (1110)	700 (1290)	800 (1470)	900 (1650)	1000 (1830)	1100 (2010)	1200 (2190)	1300 (2370)	1400 (2550)
20	0.917	1.023	1.128	1.233	1.338	1.443	1.548	1.653	1.758
19.5	1.394	1.553	1.713	1.872	2.032	2.192	2.351	2.511	2.671
19	1.882	2.098	2.313	2.529	2.744	2.960	3.175	3.391	3.607
18.5	2.383	2.657	2.930	3.203	3.476	3.749	4.022	4.295	4.568
18	2.899	3.231	3.563	3.895	4.227	4.559	4.891	5.223	5.555
17.5	3.428	3.821	4.214	4.607	4.999	5.392	5.795	6.177	6.570
17	3.974	4.429	4.884	5.339	5.794	6.249	6.705	7.160	7.615
16.5	4.535	5.054	5.574	6.093	6.613	7.132	7.652	8.171	8.691
16	5.114	5.699	6.285	6.871	7.457	8.042	8.628	9.214	9.800
15.5	5.711	6.365	7.019	7.673	8.327	8.981	9.635	10.289	10.944
15	6.327	7.052	7.777	8.501	9.226	9.951	10.676	11.400	12.125
14.5	6.965	7.762	8.560	9.358	10.156	10.954	11.751	12.549	13.347
14	7.625	8.498	9.371	10.245	11.118	11.991	12.865	13.738	14.612
13.5	8.308	9.260	10.212	11.164	12.115	13.067	14.019	14.970	15.922
13	9.018	10.051	11.084	12.117	13.150	14.183	15.216	16.249	17.282
12.5	9.756	10.873	11.991	13.108	14.226	15.343	16.461	17.578	18.695
12	10.523	11.729	12.934	14.139	15.345	16.550	17.756	18.961	20.167
11.5	11.324	12.621	13.918	15.215	16.512	17.809	19.106	20.403	21.700
11	12.159	13.552	14.945	16.338	17.731	19.124	20.516	21.909	23.302
10.5	13.034	14.527	16.020	17.513	19.006	20.499	21.992	23.486	24.979
10	13.952	15.550	17.148	18.746	20.344	21.942	23.540	25.139	26.737
9.5	14.916	16.625	18.333	20.042	21.751	23.459	25.168	26.877	28.585
9	15.933	17.758	19.583	21.408	23.233	25.058	26.883	28.709	30.534
8.5	17.008	18.956	20.904	22.852	24.801	26.749	28.697	30.645	32.593
8	18.148	20.227	22.305	24.384	26.463	28.542	30.620	32.669	34.778
7.5	19.361	21.579	23.797	26.015	28.223	30.450	32.668	34.886	37.104
7	20.659	23.025	25.392	27.758	30.124	32.491	34.857	37.224	39.590
6.5	22.052	24.578	27.104	29.630	32.156	34.683	37.209	39.735	42.261
6	23.557	26.256	28.954	31.653	34.351	37.050	39.748	42.447	45.145
5.5	25.194	28.080	30.965	33.851	36.737	39.623	42.509	45.395	48.281
5	26.986	30.077	33.168	36.259	39.351	42.442	45.533	48.624	51.715
4.5	28.967	32.285	35.603	38.922	42.240	45.558	48.876	52.194	55.512
4	31.182	34.754	38.326	41.897	45.469	49.041	52.613	56.185	59.757
3.5	33.693	37.552	41.412	45.271	49.131	52.990	56.850	60.709	64.569
3	36.592	40.783	44.975	49.166	53.358	57.549	61.741	65.932	70.124
2.5	40.020	44.604	49.189	53.773	58.357	62.941	67.525	72.110	76.694
2	44.216	49.281	54.346	59.411	64.476	69.541	74.605	79.670	84.735
1.5	49.626	55.310	60.995	66.680	72.364	78.049	83.733	89.418	95.102
1	57.250	63.808	70.366	76.924	83.482	90.040	96.598	103.156	109.714
0.5	70.285	78.336	86.387	94.438	102.488	110.539	118.590	126.641	134.692
0.2	87.515	97.540	107.564	117.589	127.614	137.638	147.663	157.687	167.712
<b>TC mV</b>									
'R'	5.582	6.741	7.949	9.203	10.503	11.846	13.224	14.624	16.035
'K'	24.902	29.128	33.277	37.325	41.269	45.108	48.828	to	to
'N'	20.609	24.526	28.456	32.370	36.248	40.076	43.836	47.502	to

These tables are based on the Nernst equation:

Probe e.m.f. =  $0.02154 \times T \times \ln \times 21/\% \text{ oxygen (Where } T = \text{ }^\circ \text{K (}^\circ \text{C} + 273) \text{)}$

# APPENDIX 3

## % OXYGEN SCALE to LOGARITHMIC

<b>% OXYGEN</b>	<b>% FULL SCALE</b>
0.1	0
0.15	7.66
0.2	13.1
0.3	20.7
0.4	26.2
0.6	33.8
0.8	39.2
1	43.5
1.5	51.1
2	56.5
3	64.2
4	69.6
6	77.3
8	82.7
10	86.9
12	90.8
14	93.3
16	95.8
18	98
20	100

# APPENDIX 4

## SAMPLE LOG PRINT OUT

Teledyne Analytical Instruments 14-07-2005 06:14:00  
Oxygen % 1.86  
EMF 1 mV 38.0  
Probe Temp 458C (856F)  
Ambient T 21.9C (71.42F)  
Servc'd 13/07/05  
Humidity 43%  
Sensor 1 Imp 5.7K  
Next Purge at 06:00:00 17-07-2005  
Next Print at 06:34:00 14-07-2005  
06:00:11 14-07-2005 Heater 1 Fail Is Active  
06:00:13 14-07-2005 O2% Low Is Active  
02:33:17 14-07-2005 RefPump Fail Accepted

# APPENDIX 5

## CIRCUIT SCHEMATICS

# APPENDIX 6

## MODBUS™ Register Map and Application Notes

MODBUS™ Functions Supported are:-

ReadHolding Register Function 3

WriteHolding Register Function 6 ( for allowable addresses only )

### Introduction.

The 9060 Analyser implements the MODBUS™ slave protocol, it is intended to work in conjunction with a MODBUS™ master.

This is accomplished by setting the MODBUS™ address to some non-zero value in the range 1-31, setting the jumper positions to select the RS485 half duplex configuration, and re-starting the transmitter.

### **The master must be configured as follows.**

Baud Rate	9600
Parity	none
Stop Bits	1
RS485 Mode	Half Duplex RTU ( binary mode)

A typical transaction would be to read the current value of a variable from the transmitter. The master send a ReadHoldingRegister packet, with the appropriate address and the transmitter responds with data at that address.

The Register Addresses are as follows, to convert to Schneider addresses for earlier model PLC's address space, add 40001 to each address.  
or for later model PLC's with linear address space the address co-responds directly to %MW XXXX address.

For Example, to read probe temperature set-point -

Read %MW1436 which is equivalent to holding register 41437 = 40001 + 1436

Some data is 32 bit data (double) which requires some care to ensure that the word order is correctly interpreted.

For Example, OXYGEN32, (dual probe) which is at address 2052 is interpreted as follows.

2052 contains the high 16 bits for probe 1 oxygen

2053 contains the low 16 bits for probe 1 oxygen

2054 contains the high 16 bits for probe 2 oxygen

2055 contains the low 16 bits for probe 2 oxygen

## Configuration and Setup Addresses

### Holding

<b>Reg.</b>	<b>Function</b>	<b>Description</b>
716	Probe #1 offset	10 = 1.0mV
717	Probe #2 offset	10 = 1.0mV

### **Purge control related variables**

754	Purge enable	0= off, 1= on
-----	--------------	---------------

### **Calibration checking gas related variables**

759	Gas calibration check	0= off, 1= 1 gas, 2= 2 gasses
2048	Probe #1 EMF	100,000 = 100.000 mV
2050	Probe #2 EMF	100,000 = 100.000 mV
2052	Probe #1 OXYGEN	100,000,000 = 100.0%
2054	Probe #2 OXYGEN	100,000,000 = 100.0%
2056	Probe #1, Impedance	1,000 = 1 k $\Omega$
2058	Probe #2, Impedance	1,000 = 1 k $\Omega$
2060	Probe #1 TC mV	100,000 = 100.000 mV
2062	Probe #2 TC mV	100,000 = 100.000 mV
2064	Probe #1 temperature	700 = 700 degC
2066	Probe #2 temperature	700 = 700 degC
2068	ALRM-ARRAY	Array of current alarm status. See below
2084	ALRM-TIMES	Array of timestamp of alarms

### **Alarm array order -**

1. Heater 1 fail
2. Sensor1 fail (Impedance too high)
3. Probe 1 filter blocked
4. Probe 1 thermocouple open circuit
5. Reference air Pump fail
6. Battery backed RAM fail
7. Mains frequency measurement fail
8. ADC warning (outside normal specifications, but still accurate)
9. DAC warning (outside normal specifications, but still accurate)

10. Oxygen % low
11. Oxygen % high
12. Oxygen % very Low
13. Oxygen % deviation too high between oxygen probes
14. Oxygen % Deficient (oxygen % low on oxygen deficient range)
15. ADC Calibration fail
16. Gas 1 calibration error
17. Gas 2 calibration error
18. Burner bypass switch on
19. Aux thermocouple open circuit
20. Reference air pump fail
21. DAC Calibration fail
22. Probe Calibration
23. Heater 2 Fail
24. Sensor 2 Fail (Impedance too high)
25. Prbe2 thermocouple open circuit
26. Probe temperature below 650 °C
27. Gas calibration check in Progress
28. Probe Purging
29. Alarm horn
30. Probe Temperature high

# INDEX

# 9060-Zirconia Analyser

<b>1</b>		CONNECTING .....	29
<b>1230 OXYGEN PROBES</b> .....	7	<b>DUST IN THE FLUE GAS</b> .....	32
<b>1231 HEATED OXYGEN PROBE</b> .....	7	<b>F</b>	
<b>1234 OXYGEN SENSOR</b>		<b>FAHRENHEIT</b> .....	49
INSTALLING .....	22	<b>FILTER BLOCKAGE</b> .....	65
<b>4</b>		<b>FILTER PURGE PRESSURE SWITCH</b> .....	11
<b>4-20 mA CALIBRATION</b> .....	46	<b>FILTER PURGING</b> .....	32
<b>A</b>		<b>FUNCTION SELECT</b> .....	44
<b>ALARM</b>		<b>H</b>	
HIGH OXYGEN .....	54	<b>HEATER FAILURE</b> .....	63
LOW OXYGEN .....	55	<b>HEATER INTERLOCK RELAYS</b> .....	25
VERY LOW OXYGEN .....	55	<b>I</b>	
<b>ALARM BUTTON</b> .....	37	<b>IMPEDANCE</b> .....	15
<b>ALARM RELAYS</b> .....	39	<b>INTERLOCK</b> .....	25
<b>ALARM SCHEDULE</b> .....	37	<b>L</b>	
<b>ALARMS</b> .....	27, 31	<b>LOWER LINE</b> .....	5
COMMON ALARM .....	37	<b>LOWER LINE DISPLAY FUNCTIONS</b> .....	50
SELECTABLE ALARMS .....	38	<b>M</b>	
SUMMARY .....	37	<b>MODEL 1232 UNHEATED OXYGEN PROBE</b> ..	7
<b>AUXILIARY TEMPERATURE</b> .....	17	<b>MODEL 1234 OXYGEN SENSOR</b> .....	7
<b>B</b>		<b>N</b>	
<b>BACKLIGHT</b> .....	39	<b>NUMBER OF SENSORS</b> .....	45
<b>BACK-UP BATTERY</b> .....	18	<b>O</b>	
<b>BATTERY</b> .....	18	<b>OPTION OR VALUE</b> .....	44
<b>BATTERY REPLACEMENT</b> .....	63	<b>OUTPUTS</b> .....	5
<b>BAUD RATE</b> .....	56	<b>OXYGEN DEVIATION</b>	
<b>BURNER BYPASS SWITCH</b> .....	39	OXYGEN DEVIATION .....	55
<b>BURNER BY-PASS SWITCH</b> .....	31	<b>OXYGEN PROBE</b>	
<b>C</b>		INSTALLING .....	20
<b>CALENDAR</b> .....	45	<b>OXYGEN PROBE</b> .....	9
<b>CALIBRATION</b>		<b>P</b>	
A/D .....	62	<b>POWER</b> .....	31
Checking of probes .....	17	<b>POWER LAMP</b> .....	39
D/A .....	62	<b>PRESSURE</b> .....	15
Electronics .....	16	<b>PRESSURE</b> .....	50, 51
Probes .....	16	<b>PRINT LOG</b>	
SENSOR .....	31	DATA .....	56
Test Points .....	62	<b>PRINTER</b>	
<b>CALIBRATION CHECK</b>		CONNECTING .....	29, 30
Connecting calibration solenoid .....	28	<b>PROBE</b>	
<b>CALIBRATION CHECKING</b> .....	4	TESTING .....	64
<b>CALIBRATION GAS CHECK</b> .....	32	<b>Probe Cable</b> .....	26
<b>CALIBRATION GASES</b> .....	53, 54	<b>PUMP REPLACEMENT</b> .....	63
<b>CENTIGRADE</b> .....	49	<b>PURGE</b> .....	17
<b>COLD START</b> .....	62	Connecting purge solenoid .....	28
<b>COMMISSIONING</b> .....	31	<b>PURGE</b>	
<b>COMMON ALARMS</b> .....	27	AUTOMATIC .....	52
<b>CONNECTIONS</b> .....	23	FREEZE TIME .....	53
<b>D</b>		<b>PURGE/CAL TIME</b> .....	52
<b>DAMPING FACTOR</b> .....	57		
<b>DISPLAY BUTTON</b> .....	36		
<b>DUAL FUEL</b> .....	51		
<b>DUAL FUEL INPUT</b>			

## R

RANGE OF INDICATION.....	5
RANGE OF OUTPUT 1.....	5
RANGE OF OUTPUT 2.....	5
REFERENCE AIR	
CONNECTING.....	29
REFERENCE AIR SELECTION.....	57
REFERENCE VOLTAGES.....	45
RELATIVE HUMIDITY.....	57
REPAIRS.....	61
RH.....	57
RS 232.....	17
RS 485.....	17
RUN MODE.....	31

## S

SENSOR TYPE.....	47
SERIAL PORT.....	29, 30
SERVICE DATE.....	47
SET-UP & RUN MODES.....	44
SET-UP FUNCTION DETAILS.....	45
SET-UP MODE.....	31
SET-UP MODE FUNCTIONS.....	42
SOFTWARE.....	1
SPECIFICATIONS.....	3, 9
STRATIFICATION.....	32

## T

TECHNICAL ENQUIRES.....	1
TESTING A PROBE.....	64
THERMOCOUPLE TYPE	
Probe.....	47
THERMOCOUPLE TYPE	
AUXILIARY.....	48
TIME.....	45
TOP LINE UNITS.....	49
TRANSMITTER 4-20 mA.....	48
TRANSMITTER	
MOUNTING.....	20
TRANSMITTER.....	15
TRANSMITTER DESCRIPTION.....	4
TRANSMITTER System.....	4

## V

VERSION.....	1
--------------	---

## W

WATCHDOG TIMER.....	18
---------------------	----

## Z

ZIRCONIA SENSOR.....	14
ZIRCONIA SENSOR OUTPUT.....	72, 73

# Declaration of Conformity

**Application of Council Directives:**

89/336/EEC (92/31/EEC)  
72/23/EEC

**Standards to which conformity is declared:**

EN550011.1:1995 (ISM, Group 1, Class B)  
EN55014:1995 (Clause 4.2)  
EN50082-2 (Industrial)  
EN61010-1  
AS61000.4.5:1999  
IEC-68-2-2  
IEC-68-2-3  
AS1099.2.6

**Manufacturer's name:** Teledyne Analytical Instruments

**Manufacturer's address:** 16830 Chestnut St  
P.O.Box 1580  
City of Industry, CA 91749-1580  
USA

**Type of equipment:** Oxygen Transmitter  
**Equipment Class:** ISM, Group 1, Class B

**Model Number:** 9060 Series Transmitter  
1231 Oxygen Probe  
1234 Oxygen Sensor

*I hereby declare that the equipment specified herein conforms to the above directive(s) and standards(s).*

Full Name: **Fraser Chapman**  
Position: **R & D Manager**

## Changes to the Manual

7-3-97 Feb 1997 version

'Case Mounting Dimensions' now has height dimension

3.12 changed 'CAL' to 'REF' and added comment for two probe ref air connection.

"Note: Filter purging is not available if two sensors was selected in set-up 1." removed from 3.21.

"Contacts must be normally closed.." in 1.4.

19-3-97 Feb 1997 version

Section 2.8, **AUTO CALIBRATION – ELECTRONICS**, altered to include the 'Warning' alarms.

24-4-97 Feb 1997 version

Changed the table of EMF/oxygen on page 57 from 820 to 720°C.

5-5-97 May 1997 version

Updated the date and version # on page 1 & 2.

Altered item 78, ref air selection, page 47.

Added item 79, Reference Air Relative Humidity to the set up menu, page 47.

Added Ref Air Fail to the common alarm list on page 34

Added to section 3.12, Connecting Reference Air, page 25

8-5-97 May 1997 version

Added imperial calculations in (brackets), by JMC, all pages.

13/14-5-97

TAB proof read correction/changes. All pages checked.

5-6-97 May 1997 version

Low Low alarm level in 5.5.70 default level and range.

Added new option in 5.5.22 and changed 5.5.23.

Changed the date and version number on page 2.

11-7-97 July 1997 version

Changed the version # and date on page 2

Added set-up item #27, Top line display ppm/%

Changed all set-up items from 27 and above, to 1 mode. (ie set-up 30 becomes 31)

Altered the first two paragraphs of section 2.3, page 14.

Altered the first paragraph of section 4.1 and display items list, page 30

6-10-97 July 1997 version

Altered the channel #1 and #2 setup items on page 40 and 41, for oxygen deficiency, #2 sensor

Altered the lower line list on page 42 to include oxygen deficiency, #2 sensor

Altered the print log list on page 46 to include oxygen deficiency, #2 sensor

Re-paginating was necessary from page 40 on....

Software version on page 2.

12-11-97 November 1997 version

Removed efficiency from channel 2 list on page 6

Removed efficiency and added combustibles to lower line on page 7

Changed 55 to 50 for the ambient temperature on page 7

Added a note in Mounting the transmitter on page 18

Changed Connecting the Aux Thermocouple on page 24

Removed efficiency from Display Functions on page 30

Added item 4.6 about the back light on page 33

Changed setup 21, probe or sensor thermocouple types on page 40

Changed setup 26, Channel 2 output. Removed efficiency and changed Co2 ranges on page 41

Removed efficiency and co in co2 in setup 29, lower line function, on page 42

Changed setup 32 and 33 in page 43

Change setup 76 data to print, on page 47

Changed the '6.2 Location of Calibration Test Points' diagram, 10 way to 16 way cable on page 50

Changed section 3.2A first paragraph page 18

Changed section 3.13 first paragraph page 26

Changed setup list on page 35

Removed efficiency from setup 24, page 41

Changed setup 32, page 43

Changed appendix 1, page 55

**2-4-98 April 1998 version**

Changed the version # and date on pages 1 & 2

Output ranges on page 6

Transmitter output channels 1 and 2, page 40 and 41

Added very low oxygen range to channel 1 (10 to 10,000ppm) page 6

**7-7-98 June 1998 version**

A large part of the manual has been changed. Re print the whole manual.

Added menu items for the new 4-20 calibration method.

Set-up 6.1 changed for the new 4-20 calibration method.

Removed the fuel selection menu item.

Moved all set-up item numbers.

Added process alarm enable menu item.

Remove the fuel type selection.

Changed sensor to probe, cell to sensor in many places

Added a 1232 connection diagram on page 22

**9-2-99 February 1999 version**

Added the index

Did a comprehensive spell and grammar check.

**16-5-99 May 1999 version**

Added menu items 34, 35 and 36 covering the variable flue pressure entry.

All menu numbers changed from 33 up.

Removed the references to a separate thermocouple being necessary for o<sub>2</sub>-def, combustibles, CO<sub>2</sub>.

Added caution 5 at the front of the manual to warn of the use of the ext pressure input dangers.

**4-6-99 May 1999 version**

Small change to sections 3.20, 3.22 and 3.6

**26-8-99 August 1999 version**

Deleted all references to the 1233 probe, including the emf table appendix

Changed the temperature limits for 253MA probes to 1000°C

Changed the probe lengths to include 1500 and 2000mm

Added variable combustibles output scaling

Added probe imp reading every 24 hours and manual instigation

Removed the flow guide tube references

Added the 47 ohm resistor for the var press input

Comment about checking the \* is on an option to lock the selection

Auto selection of minutes/seconds print log

**30-8-99 September 1999 version**

Added FIL-3 disclaimer (page 9)

**11-11-99 September 1999 version**

Removed the O<sub>2</sub> deficiency requiring a Flue thermocouple, in section 2.13

**2-2-2000 February 2000 version**

Updated the EPROM version number/date

Added 3.25 to the contents at the beginning of Chapter 3.

Completed the cal check comment 3.25

20/06/2000 P48 Step 34. "Flue Pressure Setup" Changed 4" WG to 1 kPa.; universal change kpa to kPa.

**20/09/2000 August 2000 version**

P43 Step 12. Changed "the underline polarity." to "the same polarity." Changed EPROM version to 2.76 dated August 2000,

26/09/00 p44, NOTE:. Changed "MAN AL" to "MAN CAL", removed "If" from the start of the sentence.

**2/10/2000 October 2000 version**

Added MODBUS™ sections of 3.15 and 2.11 and Appendix 6

**12/11/2000 October 2000 version**

Changed "process temperature" to "process pressure".

**14/12/00 October 2000 version**

## 9060-Zirconia Analyser

Removed "it is acknowledged that" from disclaimer. Changed telephone and fax numbers to international format. (TAB)

### **19/12/00 October 2000 version**

Fixed errors relating to the set-up menu item numbers. (TAB)

### **20/12/00 October 2000 version**

Added BB RAM Fail to the list of common alarms in section 3.10, Connecting the Alarms

### **06/02/01 October 2000 version**

Corrected alarm description numbering in section 4.3.2 – TAB

### **09/02/01 October 2000 version**

Corrected alarm description "heater bypass" to "burner bypass" – TAB

### **10/05/01 Corrected more typo's. – TAB**

### **9/10/01 November 2001 version**

Changed the EPROM version number to 2.16.

Added a note to Setup 63, freeze time set to zero, not freeze of outputs.

Added extended menus to section 5.1

Removed the note about heaters failing if left in setup for more than 2 minutes.

Added section 2.9 MANUAL CALIBRATION CHECKING - PROBES

Moved all references to section 2.9 to 2.14

Added extended set-up items 89-91, Low oxygen cal and 4-20mA limit yes/no

Added average to channel 2 in section 1 setup specifications and 5.5.28 and 5.5.30.

Added the SSR Fail alarm to 4.3.1.

Added comments linking to set-up 91 in the output channel setups.

### **4/11/01 November 2001 version**

Changed the note comments for print log on page 55/56.

### **20/02/02 February 2002 version**

Colourised manual

### **5/04/02 Colour MK1 version**

Replaced photograph with word drawing in section 5.4

### **9/04/02 Colour MK1 version**

Added MODBUS™ to the contents list on p1.

### **26/06/02 Colour MK1 version**

Font size of the LCD display in chapter 5 changed.

### **19/07/02 Colour MK1 version**

Made odd and even footers the same colour, made set-up menu consistent, added ™ to modbus. (TAB)

### **04/09/02 Colour MK1 version**

Changed page 1 – updated copyright information, added website details (JPM)

### **14/10/02 Colour MK1 version**

Added MODBUS comment to specifications and description

### **5/6/03 June 2003 version**

Updated the drawing in Section 5.3 to mirror the new labels

## 9060-Zirconia Analyser

### **22/7/03 June 2003 version**

Cosmetic changes for manual consistency (TAB)

### **16/01/04 June 2003 version**

Changed FIL-3 warning to reflect the current standard (TAB)

### **19/03/04 June 2003 version**

Added comment in chapter 6.6 about the fuses (FHC)

### **10/08/04 June 2003 version**

Changed section 4.3.2 to reverse the statement on the probe temperature alarm (FHC)

### **1/10/04 June 2003 version**

Changed the network drawing connections on page 30

### **5/10/04 June 2003 version**

Added the declaration of Conformity on the last page

### **16/01/05 June 2003 version**

Changed transmitter dimensional drawing to larger case (TAB)

### **31/01/05 January 2005 version**

Added conformance for "Equipment Ratings" and "Equipment Installation" as per section 5.4.2 & 5.4.3 of 61010-1 IEC:2001 (TAB)

### **31/08/05 August 2005 version**

Added auto cal options.

Added extended menu items

### **19/10/05 October 2005 Version**

Corrected Index page numbers

### **06/12/05 October 2005 Version**

Changed analyser to transmitter and fixed several typos.

### **14/03/06 October 2005 Version**

Added transmitter dimensions in 1.1