OPERATING INSTRUCTIONS

Model 7120

Photometric IR Analyzer

Table of Contents

Explosion Proof for
Class I, Division I, Groups B, C, D

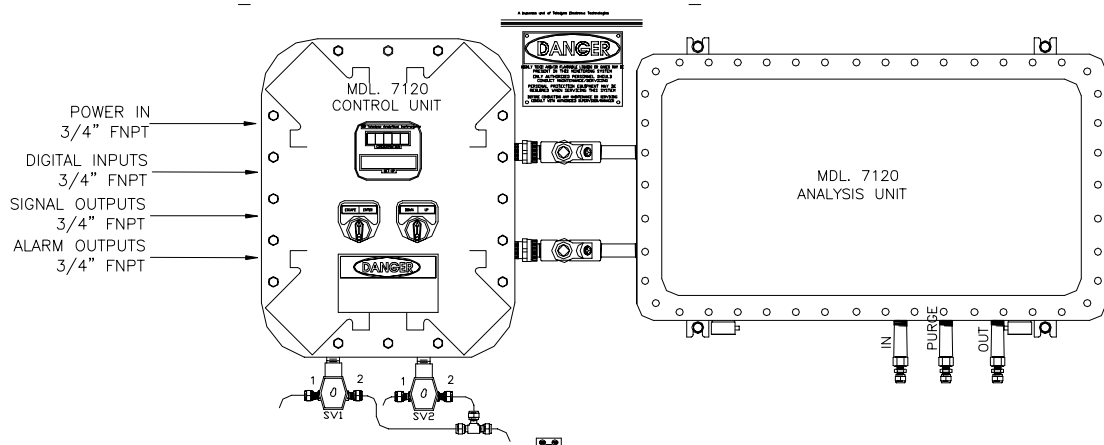

Table of Contents

1 Introduction

| | |
|---|-----|
| 1.1 Overview | 1-1 |
| 1.2 Typical Gas Applications | 1-1 |
| 1.3 Main Features of the Analyzer | 1-2 |
| 1.4 General | 1-3 |
| 1.5 NDIR Analyzer | 1-3 |

2 Installation

| | |
|--|------|
| 2.1 Unpacking the Analyzer | 2-1 |
| 2.2 Installing & Connecting the Analyzer | 2-1 |
| 2.2.1 I User Connections | 2-2 |
| 2.2.2 Electrical Power Connections | 2-2 |
| 2.2.3 Calibration Gases | 2-2 |
| 2.2.4 Pipe Connection | 2-3 |
| 2.2.5 Sample Delivery System | 2-3 |
| 2.2.6 Venting the System | 2-3 |
| 2.3 Electrical Connections (rear Panel) | 2-3 |
| 2.3.1 Primary Input Power | 2-4 |
| 2.3.2 Fuse Installation | 2-4 |
| 2.3.3 50-Pin Equipment Interface Connector | 2-4 |
| 2.3.3.1 Analog Outputs | 2-4 |
| 2.3.3.2 Alarm Relays | 2-6 |
| 2.3.3.3 Digital Remote Cal Input | 2-7 |
| 2.3.3.4 Range ID Relays | 2-9 |
| 2.3.3.5 Network I / O | 2-9 |
| 2.3.3.6 Remote Valve Connector | 2-9 |
| 2.3.4 RS-232 Port | 2-10 |
| 2.4 Gas Requirements | 2-12 |
| 2.5 Testing the System | 2-12 |
| 2.6 Calibration | 2-12 |
| 2.6.1 Calibration Fluids | 2-12 |
| 2.6.2 Calibration | 2-13 |

| | | |
|----------|---|------------|
| 3 | Start-up and Theory of Operation | 3-1 |
| 3.1 | Preliminary | 3-1 |
| 3.2 | NDIR Analyzer set-up | 3-1 |
| 3.2.1 | Initial Set-up and Zeroing | 3-1 |
| 3.2.2 | Operational Calibration | 3.2 |
| 3.3 | Theory of Operation | 3-2 |
| 3.3.1 | General | 3-2 |
| 3.4.2 | Analyzer | 3-3 |
| 3.4 | Circuit Description | 3-5 |
| 3.5 | Digital Signal Processing & Electronics | 3-6 |
| 3.6 | Linearizer | 3-7 |
| 3.7 | Control Unit | 3-8 |
| 3.8 | Automatic Function | 3-9 |
| | | |
| 4 | Operation: Electrical/Control Unit Modes/Functioning | |
| 4.1 | Introduction | 4-1 |
| 4.2 | Using the Controls | 4-2 |
| 4.2.1 | Mode/Function Selection | 4-2 |
| 4.2.1.1 | Analysis Mode | 4-2 |
| 4.2.1.2 | Setup Mode | 4-4 |
| 4.2.2 | Data Entry | 4-5 |
| 4.2.2.1 | Enter | 3-5 |
| 4.2.2.2 | Escape | 3-5 |
| 4.3.2 | Setting up Auto-Cal | 4-6 |
| 4.3.3 | Password Protection | 4-7 |
| 4.3.3.1 | Entering the Password | 4-7 |
| 4.3.3.2 | Installing or Changing the Password | 4-8 |
| 4.3.4 | Logging Out | 4-9 |
| 4.3.5 | System Self-Diagnostic Test | 4-9 |
| 4.3.6 | The Model Screen | 4-10 |
| 4.3.7 | Checking Linearity with Algorithm | 4-10 |
| 4.3.8 | Trouble Shooting Information | 4-11 |
| 4.3.9 | Digital Filter Setup | 4-12 |
| 4.3.10 | Zero Offset Adjustment | 4-13 |
| 4.3.11 | CAL-OUT Function | 4-14 |
| 4.4 | The <i>Zero</i> and <i>Span</i> Functions | 4-16 |
| 4.4.1 | Zero Cal | 4-16 |
| 4.4.1.1 | Auto Mode Zeroing | 4-17 |
| 4.4.1.2 | Manual Mode Zeroing | 4-18 |
| 4.4.1.3 | Cell Failure | 4-18 |

| | | |
|----------|---|------|
| 4.4.2 | Span Cal | 4-19 |
| 4.4.2.1 | Auto Mode Spanning | 4-19 |
| 4.4.2.2 | Manual Mode Spanning | 4-20 |
| 4.5 | The <i>Alarms</i> Function | 4-21 |
| 4.6 | The <i>Range</i> Select Function | 4-23 |
| 4.6.1 | Manual (Select/Define Range) Screen | 4-23 |
| 4.6.2 | Auto Screen | 4-24 |
| 4.6.3 | Precautions | 4-25 |
| 4.7 | The <i>Analyze</i> Function | 4-26 |
| 4.8 | Programming | 4-27 |
| 4.8.1 | The Set Range Screen | 4-27 |
| 4.8.2 | The Curve Algorithm Screen | 4-29 |
| 4.8.2.1 | Checking the Linearization | 4-29 |
| 4.8.2.2 | Manual Mode Linearization | 4-30 |
| 4.8.2.3 | Auto Mode Linearization | 4-31 |
| 4.9 | Special Function Setup | 4-32 |
| 4.9.1 | Offset Output / Reverse Output | 4-32 |
| 4.9.1.1 | Output Signal Reversal | 4-32 |
| 4.9.1.2 | Output Signal Offset | 4-33 |
| 4.9.2 | Polarity Reversal | 4-33 |
| 4.9.3 | Gain Preset | 4-34 |
| | | |
| 5 | Maintenance | |
| 5.0 | Fuse Replacement | 5-1 |
| 5.1 | Routine Maintenance | 5-2 |
| 5.2 | Filter | 5-2 |
| 5.3 | NDIR Analyzer Measurement Cell | 5-3 |
| 5.4 | System Self Diagnostic Test | 5-3 |
| 5.5 | Major Internal Components | 5-4 |
| 5.6 | Troubleshooting | 5-7 |
| 6.7 | General | 5-7 |
| 5.8 | Troubleshooting Chart | 5-8 |
| | | |
| A | Appendix | |
| | Model 7120 Specifications | A-1 |
| | Recommended 2-Year Spare Parts List | A-4 |
| | Drawing List | A-4 |
| | Exceptions, Gas Cnditions | A-6 |

1.0 Introduction

1.1 Overview

The Teledyne Analytical Instruments Model 7120 Analyzer, is versatile microprocessor-based instrument.

The manual covers the Model 7120 Explosion Proof Bulk mounted analyzer. Consisting of an Analysis section and Control Unit section. The 7120 Analyzer is for indoor or protected use in Explosion Proof environments only.

1.2 Typical Gas Applications

Typical applications of the Model 7120 are for ppm's to % ranges:

- 95 to 100%CO₂ purity for the Beverage Industry
Other gas purity applications are: 90 or 95-100% CO, 98-100% C₂H₄ (ethylene), 90-100% CH₄ (methane). Others possible, consult factory.
- 500 to 2000ppm ranges of H₂Ov in INERT GASES, CL₂, COCL₂, CO, CO₂, etc. % levels also possible.
- Chemical/Petrochemical: FCC gases, off gases, reforming/process gases: CO, CH₄, C₂...C₆, C₂H₄, etc.
- Ammonia Plants: Catalyst protection, process control: CO, CO₂, NH₃
- Ethylene Plants C₂H₄ purity, CO, CO₂, CH₄
- H₂, Syn/Natural Gas, Fuel cell plants 90 or 95%-100% CO purity, CO₂, CH₄
- Iron plants or Metal Processing Coke, Blast, Electric furnaces: CO, CO₂, CH₄
- All Industries Drying ovens, moisture control

-
- Sulfuric acid plants 0-15% SO₂, 1000ppm CO, 20%CO₂
 - Blanketing of perishables Leak detection, fermentators, controlled atmospheres
 - Carbon bed breakthrough detection ppm's to % levels, CO, CO₂, HC's
 - Mining/Landfill/Sewerage CO, CO₂, CH₄, C₂-C₆ HC's, H₂Ov (500ppm to 8% possible)

1.3 Main Features of the Analyzer

The Model 7120 Photometric Analyzer is sophisticated yet simple to use. The main features of the analyzer include:

- A easy-to-use front panel interface that includes a red 5-digit LED display and a vacuum fluorescent display, driven by microprocessor electronics, that continuously prompts and informs the operator.
- High resolution, accurate readings of concentration from low ppm levels through to 100%. Large, bright, meter readout.
- Versatile analysis over a wide range of applications.
- Microprocessor based electronics: 8-bit CMOS microprocessor with 32 kB RAM and 128 kB ROM.
- Three user definable output ranges (from 0-100 ppm through 0-100 %) allow best match to users process and equipment.
- Calibration range for convenient zeroing or spanning.
- Auto Ranging allows analyzer to automatically select the proper preset range for a given measurement. Manual override allows the user to lock onto a specific range of interest.
- Two adjustable concentration alarms and a system failure alarm.
- Extensive self-diagnostic testing, at startup and on demand, with continuous power-supply monitoring.
- RS-232 serial digital port for use with a computer or other digital communication device.
- Analog outputs for concentration and range identification. (0-1 V dc standard, and isolated 4-20 mA dc)
- Superior accuracy.

1.4 General

A dual channel electro optical infrared analyzer is utilized to continuously monitor either percentage or Part Per Million (PPM) concentrations of the gas of interest. Measurements are displayed on integral digital display. The system is insensitive to the thermal, spectral interference, contamination and zero drift problems normally associated with systems employing IR photometers.

Sample preparation requirements are absolutely minimal and entail only cooling and the automatic removal of heavier particles. Drying of the sample is unnecessary provided no condensation can occur for ambient and sample temperatures and pressures.. The system is simple, cost effective, and contains no critical orifices, sample blending, or processing that might contribute to increased maintenance and system downtime.

Additional features include direct reading linear output and an electronic automatic zero that compensates for analyzer drift over a period of time.

1.5 NDIR Analyzer

The analyzer is a non-dispersive infrared (NDIR) gas analyzer measuring the concentration of one gas of interest in a multicomponent gas mixture. The measurement is accomplished by the infrared absorption of the desired component in the mixture.

Basically, the analyzer consists of an optical unit for gas analysis and an output Control Unit. The simplicity of construction of the overall analyzer makes it one of the most advanced in the industry.

The optical unit contains an infrared energy dual element source, an optical chopper, measurement and reference tubes, optical filter and detector. The detection circuitry is mounted on its own printed circuit board for convenient servicing and signal tracing. Test points have been provided at major points required for adjustment and calibration.

Linearization is accomplished through software providing a linear output voltage and/or current with the full scale range of the interest gas concentration. Circuitry necessary to drive the display and to provide voltage and/or current outputs for external recorders or indicators is located in the control Unit. Software timer used, for automatically zeroing the analyzer, can be programmed on the front panel.

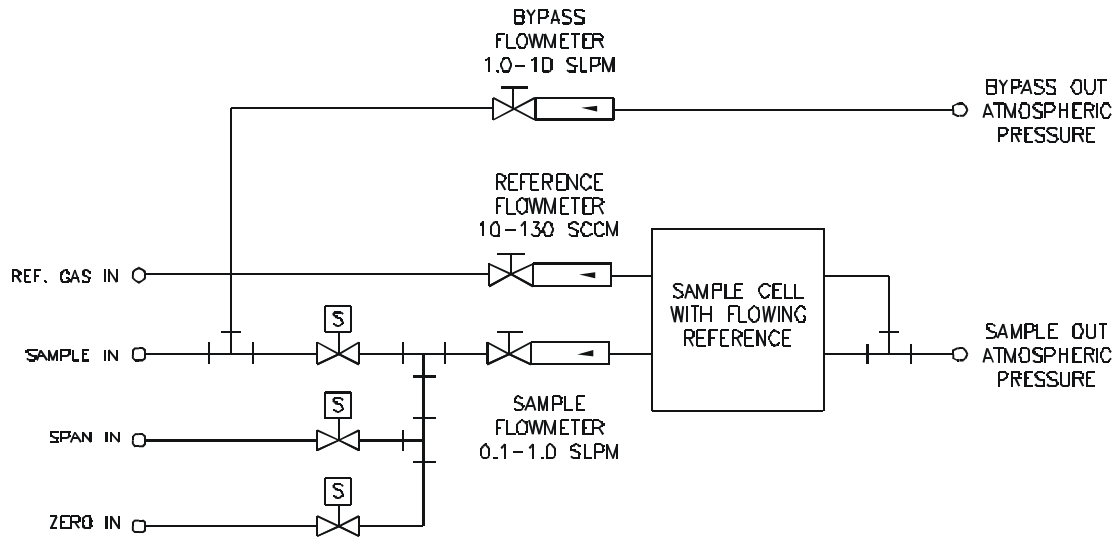

7120 piping schematic (typical)

2.0 Installation

Installation of the Model 7120 Infrared Gas Analyzer includes:

1. Unpacking
2. Mounting
3. Gas connections
4. Electrical connections
5. Testing the system.

2.1 Unpacking the Analyzer/Inspection

The analyzer is shipped with all the materials you need to install and prepare the system for operation. Carefully unpack the analyzer and inspect it for damage. Immediately report any damage to the shipping agent.

2.2 Installing and Connecting the Analyzer

The 7120 analyzer is explosion proof and designed for bulkhead mounting in hazardous environments. It must be installed in an area where the ambient temperature is not permitted to drop below 32°F nor rise above 100°F. In areas outside these temperatures, auxillary heating/cooling must be supplied. The 7120 enclosure is oil and dust resistant though designed to resist moisture. Mounting to walls or racks must be made securely. Avoid locations that are subject to extreme vibration and sway.

Sufficient space must be provided around the analyzer to accommodate the necessary electrical conduit and plumbing connections. The front door must be allowed to pull out for possible service access to all components of the enclosure. Refer to the system/analyzer outline drawings for dimensions.

Regardless of configuration, the analyzer/system must be installed on a level surface with sufficient space allocated on either side for personnel and test equipment access. Subject to the foregoing, the Analyzer/System should be placed as close to the sample point as possible and bolted to its supporting

surface. When installed as a system with enclosure (non-panel or rack mounted) a waterproof mastic should be liberally applied to the under surfaces of all supporting legs of the cubicle system before placing it in position and bolting it in place. Do allow enough space in front of the enclosure to swing the door open (a 16 1/4 radius as shown on Fig. 2-1).

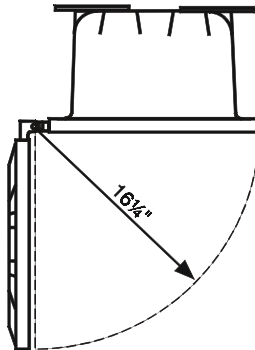

Figure 2-1: Required Front Door Clearance

2.2.1 User Connections

All user connections are made via cables which enter the explosion-proof housing through ports on its side. No conduit fittings are supplied. The installer must provide two 3/4" NPT and two 1" NPT adapters and the appropriate sealing conduit.

2.2.2 Electrical Power Connections

The standard power requires a supply of 100-125VAC, single-phase power. Power connections are made inside the analyzer at the properly labeled strip terminal. Refer to the input-output diagram for more information. The electrical power service must include a high-quality ground wire. A high-quality ground wire is a wire that has zero potential difference when measured to the power line neutral. 220 or 240 VAC, 50/60 Hz power is optional. Check the analyzer input-output diagram, power schematic, outline, and wiring diagrams for incoming power specifications and connecting points.

Warning: Primary power to the system should not be supplied until all customer wiring is inspected properly by start-up personnel.

2.2.3 Calibration Gases

The system may require a supply of clean, oil and particulate free air for use as zero gas.

For accurate calibration, the analyzer requires a blended gas mixture, typically 80-90% of the full scale range. For example: a 0-1% CO analyzer, should use a 0.8 to 0.9% CO in N₂ bottled mixture. The gas blend should be a working certified standard, analyzed by the gas supplier to at least 2% accuracy.

Do not restrict the bypass, sample or reference vents of the analyzer (and sample system when provided). All lines must vent to a stable safe area-typically 1 ATM A +/- 0.005 pressure (0 psig +/- 0.07). Be sure to vent the analyzer exit to atmospheric unless otherwise indicated by the system piping schematic. Refer to the system outline, piping schematics for proper connections and flow paths of the analysis system.

2.2.4 Pipe Connections

Refer to Appendix Piping Drawings for information about pipe connections. On special systems, consult the text in the manual that describes your particular sample system in detail.

2.2.5 Sample Delivery System

The sample delivery system should be designed to operate reliably and must be of large enough capacity to avoid flow stops. A pump is required only if there is insufficient pressure to reliably supply the sample to the system equipment panel. Do not complicate the delivery system by adding a pump unless it is absolutely necessary. If a pump is required, select a type that can handle the sample (corrosion), as well as meet the area classification and Environmental conditions.

2.2.6 Venting the System

In gas analysis systems, the system vent manifold or bypass/sample vents must terminate in a safe area as the sample may be poisonous, corrosive or flammable.

2.3 Electrical Connections

Figure 2-2 shows the Model 7120 interface panel. There are connectors for power, digital communications, and both digital and analog concentration output.

For safe connections, no uninsulated wiring should be able to come in contact with fingers, tools or clothing during normal operation.

CAUTION: *Use Shielded Cables. Also, use plugs that provide excellent EMI/RFI protection. The plug case must be connected to the cable shield, and it must be tightly fastened to the analyzer with its fastening screws. Ultimately, it is the installer who ensures that the connections provide adequate EMI/RFI shielding.*

2.3.1 Primary Input Power

The power strip is located at the interface panel inside the analyzer.

DANGER: *POWER IS APPLIED TO THE INSTRUMENT'S CIRCUITRY AS LONG AS THE INSTRUMENT IS CONNECTED TO THE POWER SOURCE. THE STANDBY FEATURE ON THE FRONT PANEL IS FOR SWITCHING POWER ON OR OFF TO THE DISPLAYS AND OUTPUTS ONLY.*

The standard power supply requires a 110 VAC, 50-60 Hz power source. 220 VAC, 50-60 Hz power-optional.

2.3.2 Fuse Installation

The fuse block, at the right of the power cord receptacle is 2A for 115VAC or 1A for 220VAC. Be sure to install the proper fuse as part of installation.

2.3.3 Terminal Block Connections

Figure 2-2 shows the terminal block layout of the Equipment Interface panel. The arrangement is shown as seen when the viewer faces the interface panel from the front of the analyzer.

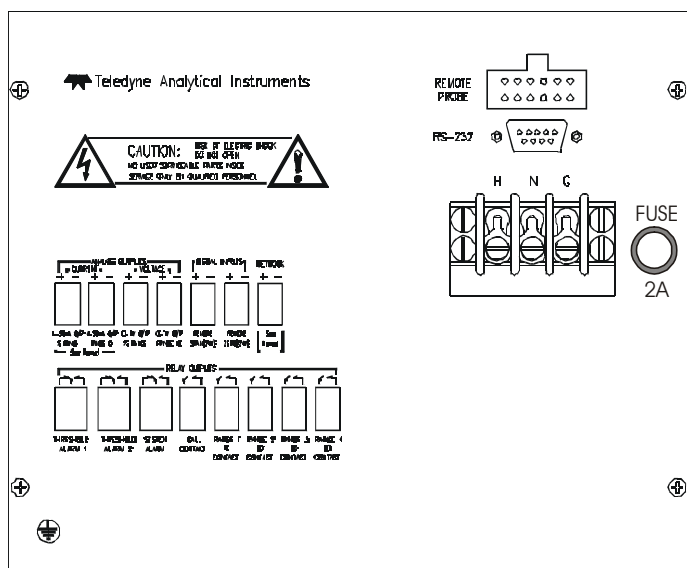

Figure 2-2: Analog Output Connections

2.3.3.1 Analog Outputs

There are four DC output signal pins—two pins per output. For polarity, see Figure 2-3. The outputs are:

- 0–1 V dc % of Range: Voltage rises linearly with increasing concentration, from 0 V at 0 concentration to 1 V at full scale. (Full scale = 100% of programmable range.)
- 0–1 V dc Range ID: 0.25 V = Range 1, 0.5 V = Range 2, 0.75 V = Range 3, 1 V = Cal Range.
- 4–20 mA dc % Range: Current rises linearly with concentration, from 4 mA at 0 concentration to 20 mA at full scale. (Full scale = 100% of programmable range.)
- 4–20 mA dc Range ID: 8 mA = Range 1, 12 mA = Range 2, 16 mA = Range 3, 20 mA = Range 4.

Figure 2-3: Analog Output Connections

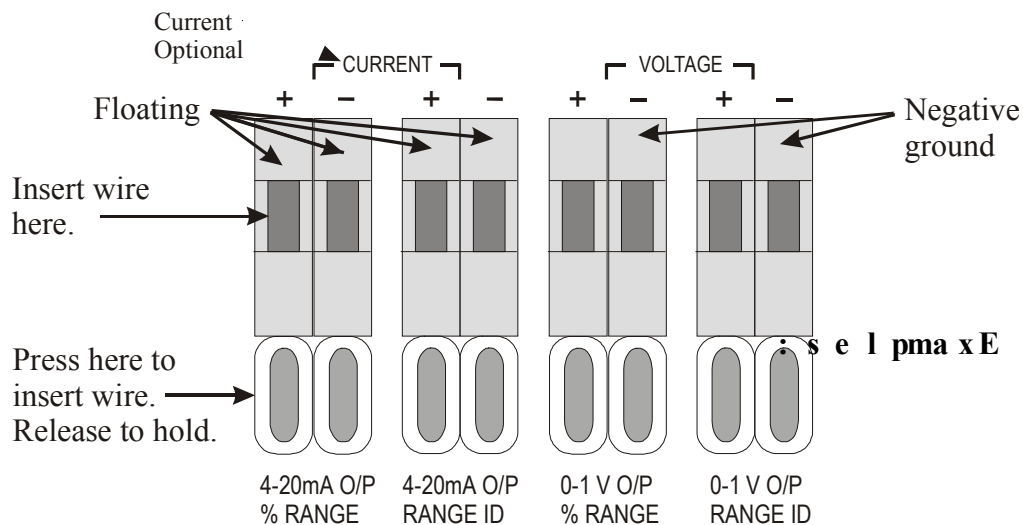

The analog output signal has a voltage which depends on gas concentration **relative** to the full scale of the range. To relate the signal output to the actual concentration, it is necessary to know what range the instrument is currently on, especially when the analyzer is in the autoranging mode.

The signal output for concentration is linear over the currently selected analysis range. For example, if the analyzer is set on a range that was defined

Examples:

The analog output signal has a voltage which depends on gas concentration **relative** to the full scale of the range. To relate the signal output to the actual concentration, it is necessary to know what range the instrument is currently on, especially when the analyzer is in the autoranging mode.

The signal output for concentration is linear over the currently selected analysis range. For example, if the analyzer is set on a range that was defined as 0–10 % hydrogen, then the output would be as shown in Table 2-3.

Table 2-3: Analog Concentration Output—Example

| Percent CO | Voltage Signal Output (V dc) | Current Signal Output (mA dc) |
|------------|------------------------------|-------------------------------|
| 0 | 0.0 | 4.0 |
| 1 | 0.1 | 5.6 |

| | | |
|----|-----|------|
| 2 | 0.2 | 7.2 |
| 3 | 0.3 | 8.8 |
| 4 | 0.4 | 10.4 |
| 5 | 0.5 | 12.0 |
| 6 | 0.6 | 13.6 |
| 7 | 0.7 | 15.2 |
| 8 | 0.8 | 16.8 |
| 9 | 0.9 | 18.4 |
| 10 | 1.0 | 20.0 |

To provide an indication of the range, the Range ID analog outputs are used. They generate a steady preset voltage (or current when using the current outputs) to represent a particular range. Table 2-4 gives the range ID output for each analysis range.

Table 2-4: Analog Range ID Output—Example

| Range | Voltage (V) | Current (mA) | Application |
|---------------|-------------|--------------|---|
| Range 1 | 0.25 | 8 | 90-100% CO/N ₂ |
| Range 2 | 0.50 | 12 | 95-100% CO/N ₂ |
| Range 3 | 0.75 | 16 | 0-100% CO/N ₂ |
| Range 4 (Cal) | 1.00 | 20 | 98-100% CO ₂ /N ₂ |

2.3.3.2 Alarm Relays

The nine alarm-circuit connector pins connect to the internal alarm relay contacts. Each set of three pins provides one set of Form C relay contacts. Each relay has both normally open and normally closed contact connections. The contact connections are shown in Figure 2-4. They are capable of switching up to 3 amperes at 250 V ac into a resistive load. The connectors are:

- Threshold Alarm 1:
- Can be configured as high (actuates when concentration is above threshold), or low (actuates when concentration is below threshold).
 - Can be configured as failsafe or nonfailsafe.
 - Can be configured as latching or nonlatching.
 - Can be configured out (defeated).
- Threshold Alarm 2:
- Can be configured as high (actuates when concentration is above threshold), or low (actuates when

concentration is below threshold).

- Can be configured as failsafe or nonfailsafe.
- Can be configured as latching or nonlatching.
- Can be configured out (defeated).

System Alarm: Actuates when DC power supplied to circuits is unacceptable in one or more parameters. Permanently configured as failsafe and latching. Cannot be defeated. Actuates if self test fails.

(Reset by pressing button to remove power. Then press again and any other button EXCEPT *System* to resume.

Further detail can be found in chapter 4, section 4-5. concentration is below threshold).

- Can be configured as failsafe or nonfailsafe.
- Can be configured as latching or nonlatching.
- Can be configured out (defeated).

System Alarm: Actuates when DC power supplied to circuits is unacceptable in one or more parameters. Permanently configured as failsafe and latching. Cannot be defeated. Actuates if self test fails.

(Reset by pressing button to remove power. Then press again and any other button EXCEPT *System* to resume.

Further detail can be found in chapter 4, section 4-5.

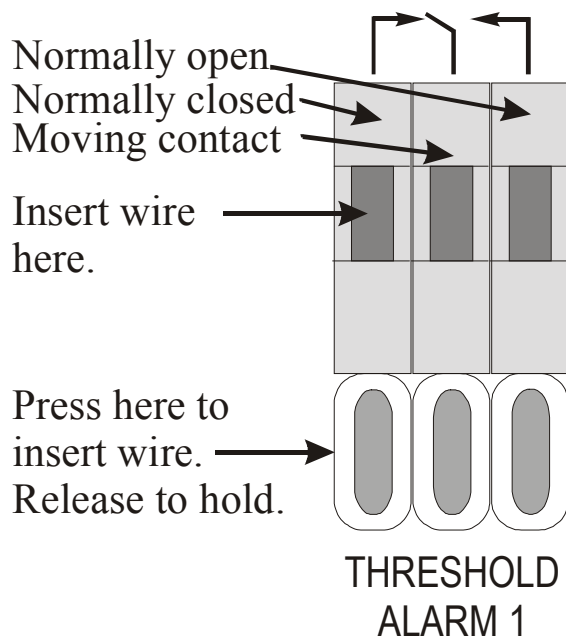
Figure 2-4: Alarm Relay Contact Pins

Remote Calibration Protocol: To properly time the Digital Remote Cal Inputs to the Model 7120 Analyzer, the customer's controller must monitor the Cal Relay Contact.

When the contact is OPEN, the analyzer is analyzing, the Remote Cal Inputs are being polled, and a zero or span command can be sent.

When the contact is CLOSED, the analyzer is already calibrating. It will ignore your request to calibrate, and it will not remember that request.

Once a zero or span command is sent, and acknowledged (contact closes), release it. If the command is continued until after the zero or span is complete, the calibration will repeat and the Cal Relay Contact (CRC) will close again.

For example:

- 1) Test the CRC. When the CRC is open, Send a zero command until the CRC closes (The CRC will close quickly.)
- 2) When the CRC closes, remove the zero command.
- 3) When CRC opens again, send a span command until the CRC closes. (The CRC will close quickly.)
- 4) When the CRC closes, remove the span command.

When CRC opens again, zero and span are done, and the sample is being analyzed.

Note: The Remote Probe connector provides signals to operate the zero and span gas valves synchronously. However, if you have the –C Internal valve option, which includes zero and span gas inputs, the 7120 automatically regulates the zero, span and sample gas flow.

2.3.3.4 Range ID Relays

Four dedicated Range ID relay contacts. For any single application they are assigned to relays in ascending order. For example: if all ranges have the same application, then the lowest range is assigned to the Range 1 ID relay, and the highest range is assigned to the Range 3 ID relay. Range 4 is the Cal Range ID relay. Figure 2-6 lists the pin connections.

Table 2-6: Remote Calibration Connections

| Pin | Function |
|-----|---------------|
| 9 | + Remote Zero |
| 11 | – Remote Zero |
| 10 | + Remote Span |
| 12 | – Remote Span |
| 40 | Cal Contact |
| 41 | Cal Contact |

Remote Calibration Protocol: To properly time the Digital Remote Cal Inputs to the Model 7120 Analyzer, the customer's controller must monitor the Cal Relay Contact.

When the contact is OPEN, the analyzer is analyzing, the Remote Cal Inputs are being polled, and a zero or span command can be sent.

When the contact is CLOSED, the analyzer is already calibrating. It will ignore your request to calibrate, and it will not remember that request.

Once a zero or span command is sent, and acknowledged (contact closes), release it. If the command is continued until after the zero or span is complete, the calibration will repeat and the Cal Relay Contact (CRC) will close again.

For example:

- 1) Test the CRC. When the CRC is open, Send a zero command until the CRC closes (The CRC will close quickly.)

- 2) When the CRC closes, remove the zero command.
- 3) When CRC opens again, send a span command until the CRC closes. (The CRC will close quickly.)
- 4) When the CRC closes, remove the span command.

When CRC opens again, zero and span are done, and the sample is being analyzed.

Note: The Remote Probe connector provides signals to operate the zero and span gas valves synchronously. However, if you have the -C Internal valve option, which includes zero and span gas inputs, the 7120 automatically regulates the zero, span and sample gas flow.

2.3.3.4 Range ID Relays

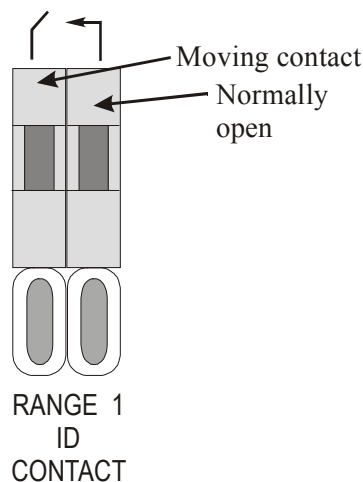

Four dedicated Range ID relay contacts. For any single application they are assigned to relays in ascending order. For example: if all ranges have the same application, then the lowest range is assigned to the Range 1 ID relay, and the highest range is assigned to the Range 3 ID relay. Range 4 is the Cal Range ID relay. Table 2-7 lists the pin connections.

Table 2-7: Range ID Relay Connections

| Pin | Function |
|-----|--------------------|
| 21 | Range 1 ID Contact |
| 38 | Range 1 ID Contact |
| 22 | Range 2 ID Contact |

- 39 Range 2 ID Contact
- 19 Range 3 ID Contact
- 18 Range 3 ID Contact
- 34 Range 4 ID Contact
- 35 Range 4 ID Contact

2.3.3.5 Network I/O

A serial digital input/output for local network protocol. At this printing, this port is not yet functional. It is to be used in future options to the instrument.

2.3.3.6 Remote Valve Connector

The 7120 is a single-chassis instrument, which has no Remote Probe Unit. Instead, the Remote Valve connector is used as another method for controlling external sample/zero/span gas valves. See Figure 2-7.

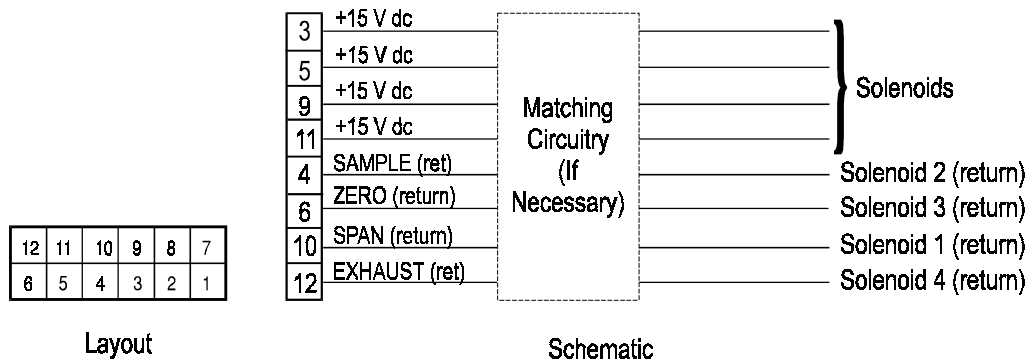

Figure 2-7: Remote Probe Connector Pinouts

The voltage from these outputs is nominally 0 V for the OFF and 15 V dc for the ON conditions. The maximum combined current that can be pulled from these output lines is 100 mA. (If two lines are ON at the same time, each must be limited to 50 mA, etc.) If more current and/or a different voltage is required, use a relay, power amplifier, or other matching circuitry to provide the actual driving current.

In addition, each individual line has a series FET with a nominal ON resistance of 5 ohms (9 ohms worst case). This could limit the obtainable voltage, depending on the load impedance applied. See Figure 2-8.

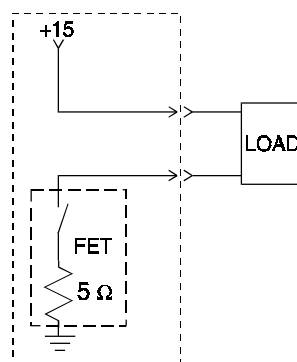

Figure 2-8: FET Series Resistance

2.3.4 RS-232 Port

The digital signal output is a standard RS-232 serial communications port used to connect the analyzer to a computer, terminal, or other digital device. It requires a standard 9-pin D connector.

Output: The data output is status information, in digital form, updated every two seconds. Status is reported in the following order:

- The concentration in ppm or percent
- The range in use (00 = Range 1, 01 = Range 2, 10 = Range 3, 11 = Range 4)
- The span of the range (0-100 %, etc)
- Which alarms—if any—are disabled (AL-x DISABLED)
- Which alarms—if any—are tripped (AL-x ON).

Each status output is followed by a carriage return and line feed.

Input: The input functions using RS-232 that have been implemented to date are described in Table 2-3.

Table 2-8: Commands via RS-232 Input

| Command | Description |
|-----------|---|
| as<enter> | Immediately starts an autospan. |
| az<enter> | Immediately starts an autozero. |
| rp<enter> | Allows reprogramming of two <i>System</i> functions: APPLICATION (gas use) and ALGORITHM (linearization). |

st<enter> Toggling input. Stops/Starts any status message output from the RS-232, until **st<enter>** is sent again.

Implementation: The RS-232 protocol allows some flexibility in its implementation. Table 2-9 lists certain RS-232 values that are required by the Model 7120 implementation.

Table 2-9: Required RS-232 Options

| Parameter | Setting |
|------------------|-----------|
| Baud | 2400 |
| Byte | 8 bits |
| Parity | none |
| Stop Bits | 1 |
| Message Interval | 2 seconds |

2.4 Gas Requirements

Instrument Air is required for zeroing of the Infrared Analyzer. It must be free of oil, particulates and water vapor (**that will not condensate, unfiltered plant air is not recommended**). A supply pressure of 10-100psig with a typical flow rate of 2 scfh (1 lpm) is needed. Bottled gas is recommended (air or Nitrogen) if high quality air is not available.

For accurate calibration, the analyzer requires blended gas mixtures certified to +/- 2% accuracy.

2.5 Testing the System

Before plugging the instrument into the power source:

- Check the integrity and accuracy of the fluid connections. Make sure there are no leaks.
- Check the integrity and accuracy of the electrical connections. Make sure there are no exposed conductors
- Check that sample pressure is controlled accurately and is maintained between 0 to 10 psig, according to the requirements of your process.

NOTE: Special designed systems may require checks under vacuum or high pressure (consult manual addendum).

Power up the system, and test it by performing the following operations:

1. Repeat the Self-Diagnostic Test, section 5.2

2.6 Calibration

2.6.1 Calibration Fluids

Zero and span fluids must be made by the chemistry lab or certified zero and span gas bought from a gas supplier. The zero fluid must be the major component of the sample, free from the component of interest. In purity applications, the accuracy is only as good as the purity of the zero gas used to reference to. The 7120 has a continuous flowing optical reference gas path that the sample is compared to, so it must be very pure, i.e, CO₂ purity of 99.995%. Typically this reference flow is about 20 ccm.

Note: In Non-purity applications, the reference cell may be sealed with clean air (consult factory).

The span fluid must be the major component of the sample mixed with a small amount of the component of interest. The concentration must be 80 to 95% of the full scale range or the widest range of the instrument (if the instrument provides more than one range). (i.e, for a 98-100% CO₂ range purity, use span of 98.40% N₂ in 99.995% pure CO₂).

2.6.2 Calibration

Refer to Section 4.4 of the manual to determine how to manipulate the mode setting. The recommended calibration method is as follows:

1. Calibration with zero and span fluids. (Note: Zero gas may be 100% gas in purity applications).

Method:

1. Introduce zero fluid and set zero as referred in section 4.4.1

NOTE: When calibrating from 0% to an upper concentration gas, obtain a zero gas (minus the analyte) that typically is as pure as the minimum resolution needed to control to. This usually meets or exceeds the minimum full scale accuracy of the measurement.

2. Introduce a span fluid and set the concentration of the span fluid. Refer to the span procedure in section 4.4.2. (Note: The span gas should typically be an 80% of full scale range gas similar to the 100% zero gas background; i.e., 100% CO₂ zero gas and a span gas of 98.4% CO₂ in N₂ for a 98-100%CO₂ purity application.

3.0 Start-up and Operation

3.1 Preliminary

Before applying power to the system, TAI suggests that the electrical wiring installation be checked against the system input-output diagram. Proper attention to this preliminary check will prevent severe damage caused by wiring errors.

Also, verify that all connections to the system have been made correctly. Refer to the system outline diagram for proper connections.

3.2 NDIR Analyzer Startup

Power up the unit by depressing the rear panel switch. From a first time power-on cold start attempt, allow (1) one hour warm-up to proceed. Observe that the Digital display will go through a diagnostic routine before the readings revert to a continuous concentration readout.

3.2.1 Initial Set-up and Zeroing

Assure the sample will enter from the zero inlet gas position. Open the zero gas tank and set the pressure regulator to 20 psig. Set the zero gas flow to 2 SCFH (1 lpm). Set the sample flow to 2 SCFH (1 lpm). When applicable, assume the flowing reference cell gas is flowing between 20-50 ccm.

Initialize a zero operation through the system menu. Refer to Section 4 for Electronics /Control Unit Modes and Functioning to navigate the zero menu.

After the zero cycle is over, the instrument is automatically brought in the sampling cycle. An inaccurate reading of the concentration of the gas of interest will be obtained. The instrument is not yet calibrated. Permit the instrument to operate in this mode for at least one hour to stabilize if not already done so upon initial power up.

NOTE: The following options could be included in your system:

In case the instrument is part of a multi instrument system, where all instruments are connected to the same sample system and under control of a single timer, all instruments of the system will go through the zero and sample cycle simultaneously. The Control Unit of the instrument which

houses the timer and operates the sampling system is called the master. The other Control Units of the other instruments are called slaves.

Each of the other instruments may be monitoring the concentration of several different gases of interest in the sample, for example CO, CO₂ and/or Combustibles as CH₄ in flue gas.

3.2.2 Operational Calibration

After the instrument has stabilized, let zero gas flow through the analyzer

Perform a zero of the analyzer.

Perform a span of the analyzer.

Open the span gas tank and set the pressure regulator to 20 psig.

Switch the mode switch to sample. Refer to Section 4 again.

Induce an automatic zero cycle as described in Section 4 also.

After the zero cycle, the analyzer reverts to the sample cycle. The sample reading is now accurate and the analyzer is placed in continuous operation. See Sections 4.6-4.8.

NOTE: In case slave analyzers are involved, calibrate them simultaneously with the master analyzer.

After the instrument is calibrated, when no Auto-Cal option was selected, shut off the main valve on the span gas tank. This tank is not used during automatic sampling. Leave the zero tank open.

3.3 Theory of operation

3.3.1 General

The non-dispersive infrared (NDIR) analyzer is one of the major components of the system. It employs the basic principles of spectroscopic analysis to measure a specific concentration of one gas in a multicomponent gas system. The concentration of a gas is determined by exposing a chamber filled with a gas mixture to infrared radiant energy and measuring how much of the specific (non-dispersive) infrared wavelength is absorbed by the gas being measured.

As an example, the NDIR analyzer is used most in flue gas applications where the amount of carbon monoxide in a flue gas mixture is measured. The specific infrared wavelength at which the carbon monoxide molecule absorbs infrared energy is at 4.65 microns. The more carbon monoxide present in the measurement cell, the more energy its molecules absorb.

The NDIR analyzer needs four basic components to measure the spectral

absorbance.

- a) A source of emitted infrared radiation to be absorbed by the gas of interest.
- b) A set of two chambers, one filled and sealed with dry air (to provide a reference— note, it may also be a flowing reference as in the case of purity gas measurements), and the other opened to accept a flowing sample gas.
- c) A detector specifically tuned to measure only the wavelength of infrared energy that will be absorbed by the gas being measured. For example, carbon monoxide requires a detector turned to 4.65 microns, while carbon dioxide needs one tuned to 4.27 microns.
- d) An electronics system to process the changes in the electronic resistance of the detector, and to convert these changes into specific electronics signals that deliver a voltage at current linearly proportional to the concentration of the gas measured. The Teledyne NDIR analyzer employs all of the above features.

3.3.2 Analyzer

The emitted IR energy is generated by two specially configured miniature lamps in parabola's focused and operating at low power of only 0.5 watts. These lamps are typically rated for 20,000 hours continuous operation when run in the DC mode (+5VDC). This collimated energy is directed through parallel infrared beams which are chopped by a beam interrupter or disc to effect an alternate on-off sequencing of each beam. The radiant energy passes through two tubes, one containing a continuously flowing sample gas, the other a non-absorbing static or flowing background gas (application dependent) (for reference). As the beam passes through the reference tube, the energy of the beam is unattenuated and balanced which provides a standard of source energy output for comparison. The gas of interest is present in the measurement tube, however, the energy of the beam will be attenuated at the specific absorption wavelength.

After passing through the two tubes, the radiant beams are reflected and imaged by a second concave mirror onto a photon detector. A spectral filter, located just in front of the detector, represents the precise "window" of the absorption band for the specific gas of interest. Energy outside the band is eliminated.

The detector converts the optical energy from the radiant beams into an electrical signal which is modulated in proportion to the gas concentration.

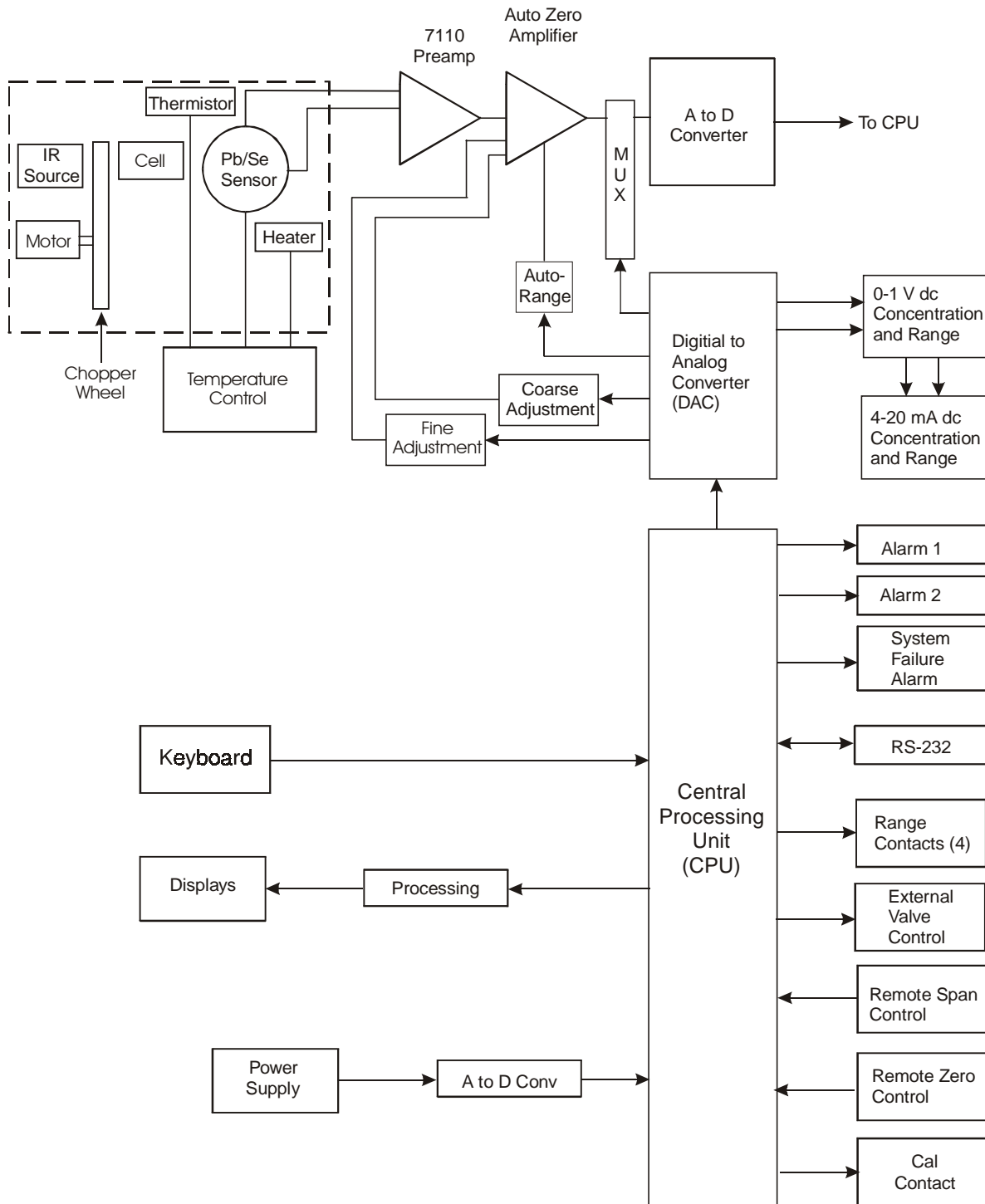

Block Diagram of the Model 7120 Electronics

3.4 Circuit Description

Infrared energy light pulses are focused on the lead Selenide (PbSe) sensor at a 400 Hz rate; this causes its photoconduction to change in proportion to the IR signal strength. Therefore photoconduction occurs, there is a minute change in the voltage level across the sensor which is noted by the two voltage followers, U1A and U1B, located on preamplifier PCB C72758, refer to schematic C28165. The infrared energy pulsations are converted into a small 400 Hz electronic waveform.

The signal is amplified by the differential amplifier, U1C, whose capacitor-coupled input blocks the DC voltage present in the input signal. This differential amplifier is designed to have a very high common mode rejection ratio. This output signal will be a series of pulses, the “reference” and “measurement” signals one after the other. These are further amplified by using the booster amplifier U1D.

The reference and measurement signals are identified by an optical system that detects the position of the chopper wheel.

The light from a light source, the optical coupler lamp, is reflected by the white parts of the collar on the chopper wheel. The reflected light causes a photoconductive element to conduct. U5A and U5B sense this and generate a square wave of corresponding width. These ID pulse trains are utilized to separate the measuring and reference signals.

The source output can fluctuate due to line voltage fluctuations, aging of the source, or contamination of the cells, resulting in corresponding signal level changes which would cause an error in the reading. This is corrected by the automatic level control (ALC) circuit, V3. Both the reference and measurement pulses are passed through the ALC, but only the reference pulse is used to control the gain of the ALC. As a result, the reference pulse, at its output, remains at a constant level despite any changes in the energy reaching the detector.

The complete video signal is first clamped to the zero level by zero restorer circuit U2C and U2D and the reference signal is separated from the video signal by a switch Q1, which is controlled by the ID pulses from U5A. This signal is fed to the rectifier input of the ALC as a controlling signal for the gain control circuit. The output reference signal level is always constant and is determined by the internal resistors of the amplifier. The measurement signal level will be equal to the input signal multiplied by the gain of the

ALC amplifier.

The output of the ALC is the video signal superimposed on a DC level. This signal is clamped to ground level by means of the zero restorer, U4A and U4B. The reference ID pulse and measurement ID pulse are used to separate their respective signals by FET switches Q2 and Q3, and the measurement peak is inverted by U4D.

The measurement pulse is fed to the auto-zero circuit which uses a digital successive-approximation technique to equalize the measurement and reference peaks while the cell contains zero gas. The auto-zero circuit holds its gain during the measurement period. As a result, any imbalance in the two peaks is corrected, and the analyzer is effectively zeroed.

The output of the auto zero circuit, i.e., the inverted measurement peak and the reference peak, is fed to a summing amplifier, U6A. The summing action adds the two waveforms to produce a single waveform with excursions above the zero level (from the reference peak), and below it (from the measurement peak). The average then corresponds to the difference between the peaks, and, properly filtered, becomes the output signal. The summed signal is fed to the low pass filter U6B, whose output is a DC signal fed to an amplifier, U6C, which produces the preamplifier output.

3.5 Digital Signal Processing & Electronics

The Model 7120 uses an 8031 microcontroller (Central Processing Unit—CPU) with 32 kB of RAM and 128 kB of ROM to control all signal processing, input/output, and display functions for the analyzer. System power is supplied from a universal power supply module designed (C65507) to be compatible with any international power source. (See *Major Internal Components* in chapter *Maintenance* for the location of the power supply and the main electronic PC boards.)

The Temperature Control board (C69535A) is set to a single voltage (110 or 220 VAC) and set the temperature of the sampling system at 45°C. The signal processing electronics including the microprocessor, analog to digital, and digital to analog converters are located on the Motherboard (C67435B) on side of the case.

The Auto-Zero amplifier PCB board is mounted on top of the Motherboard. These boards are accessible by sliding the system out of the case.

The Temperature Control Board keeps the temperature of the measuring cell regulated to within 0.1 degree C. A thermistor is used to measure the

temperature, and a zero-crossing switch regulates the power of the heaters inside the sample chamber. The result is a sensor output signal that is temperature independent.

The output of the preamp is fed to variable gain amplifier, which provides automatic range switching under control of the CPU. The output from the variable gain amplifier is sent to an 18 bit analog to digital converter.

The digital concentration signal along with input from the control panel is processed by the CPU and passed on to the 12-bit DAC, which outputs 0-1 V dc Concentration and Range ID signals. An voltage-to-current converter provides 4-20 mA dc concentration signal and range ID outputs.

The CPU also provides appropriate control signals to the Displays, Alarms, and External Valve Controls, and accepts digital inputs for external Remote Zero and Remote Span commands. It monitors the power supply through an analog to digital converter as part of the data for the system failure alarm it performs timing and linearizing tasks too.

The RS-232 port provides two-way serial digital communications to and from the CPU. These, and all of the above electrical interface signals are described in detail in chapter 3 *Installation*.

3.6 Linearizer

The output of the NDIR analyzer bench is non-linear (this is due to the effect known as “Beers Law”). Figure I shows this non-linear response.

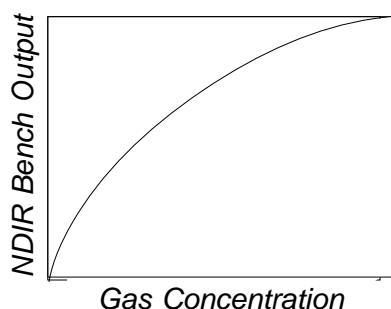

In order to produce a linear signal response, a compensation curve is required (see Figure II). Therefore, a linearizer software routine is included

to create a linear response. Refer to section 4.3.7 and 4.8.2 to see how linearizer is programmed.

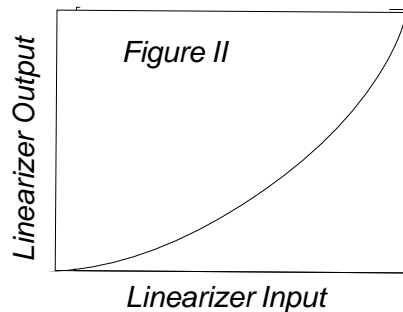

Piece-wise approximation is the method used to linearize the signal, i.e., the linearizer's output to input relationship can be graphed as a number of straight line segments connected together to approximate the desired curve that would be required to compensate for the nonlinearity of the bench

The points at which the compensation curve changes slope are called breakpoints. The slope of each segment corresponds to the gain of the linearizer in that segment, and this gain has to vary according to the input voltage. This is achieved through software by adjusting a multiplier factor at each straight line segment. The linearizer has nine specific voltage segments.

3.7 Control Unit

The Control Unit that controls the zero cycle and the sample system, which may be common for all other Control Units is called the Slave Control Unit. The master is unique because it contains the timer PC board and mode switching programming for operation of any internal/external calibration or auxillary valving.

The master control unit drives the other control units called slaves. The slave control unit has all the features of the master except timing and control of the sample system.

When a system contains the automatic calibration option, all control units are slaves. The Auto-Cal function controls the sample system and the zero cycle and provides a span cycle.

3.8 AUTOMATIC FUNCTION

The events taking place during a zero cycle are as follows:

1. The zero cycle starts with activation of the calibration contact. The analyzer outputs are held during the zero cycle.
2. The Auto Zero solenoid valve is activated and zero gas replaces the sample. (This valve may be internal or external to the Model 7100 enclosure).
3. At about minute one in the cycle. The Auto Zero board then begins its zeroing function, adjusting the processing circuitry of the analyzer to develop a zero signal output. During this period, the analyzer display may swing from below zero to above fullscale several times before it finally settles to zero output. The "hold" feature prevents these wide output excursions from affecting the analog output and trigger alarms. The Auto Zero circuit board function takes about 6 minutes to complete. It is important that zero gas is continually purging the cell during this time.
4. At around the 5th minute, the Auto Zero solenoid valve is deactivated and sample replaces the zero gas.
5. The hold feature is deactivated and the display starts reading the sample again, and the analog output soon starts tracking.

This concludes the zero cycle.

The time between zero cycles, may be programmed to last from one (1) to 23 hours.

For "Purity Measurements" typical zeroing is performed every 3 hours. This may increase or decrease depending upon the complexity of the application involved.

Operation

4.1 Introduction

Although the Model 7120 is usually programmed to your application at the factory, it can be further configured at the operator level, or even, **cautiously**, reprogrammed. Depending on the specifics of the application, this might include all or a subset of the following procedures:

- Setting system parameters:
 - Establish a security password, if desired, requiring Operator to log in.
 - Establish and start an automatic calibration cycle, if desired.
- Routine Operation:
 - Calibrate the instrument.
 - Choose autoranging or select a fixed range of analysis.
 - Set alarm setpoints, and modes of alarm operation (latching, fail-safe, etc).
- Program/Reprogram the analyzer:
 - Define new applications.
 - Linearize your ranges.
- Special functions setup:
 - Set output reversal.
 - Set polarity reversal or offset output.S
 - Set gain amplification.

Before you configure your 7120, the following default values are in effect: RANGE/APPLICATIONS: refer to data sheet on the first page of this manual;

Range: Manual

Alarm Relays: Defeated, 0.00%, HI, *NOT* Fail/Safe, not latching

Zero: Auto, every 0 days 0 hours

Span: Auto, at 10%, every 0 days, at 0 hours

Password: TAI

4.2 Using the Controls

To get the proper response from these controls, press the desired key (ESCAPE or ENTER—DOWN or UP). To enter the screen menu, press any key.

The item that is between arrows on the screen is the item that is currently selectable by pressing the ENTER enter key.

In these instructions, to ENTER means to press the ENTER KEY, and to ESCAPE means to press the ESCAPE KEY. To scroll UP (or scroll DOWN) means to press UP or DOWN keys as many times as necessary to reach the required menu item.

4.2.1 Mode/Function Selection

When the analyzer is first powered up, and has completed its initialization and self diagnostics, ESCAPE toggles the instrument between the ANALYZE screen (*Analysis Mode*) and the MAIN MENU screen (*Setup Mode*). The ANALYZE screen is the only screen of the *Analysis Mode*.

The MAIN MENU screen is the top level in a series of screens used in the *Setup Mode* to configure the analyzer for the specific application. The DOWN/UP commands scroll through the options displayed on the VFD screen. The selectable option appears between arrows. When you reach the desired option by scrolling, ENTER the selection as described below.

ESCAPE takes you back up the hierarchy of screens until you reach the ANALYZE MODE. ESCAPING any further just toggles between the MAIN MENU and the ANALYZE screen.

NOTE: *The main menu times out after 5 (five) seconds, returning to the analyze screen. Submenus time out after 10 minutes.*

4.2.1.1 Analysis Mode

This is the normal operating mode. The analyzer monitors the concentration of the mixture content of the sample, displays the percent of the concentration in the sample stream, and warns of any alarm conditions. Pressing any key switches you to *Setup Mode*. *Setup Mode* switches back to *Analysis Mode* if no controls are used for more than five seconds.

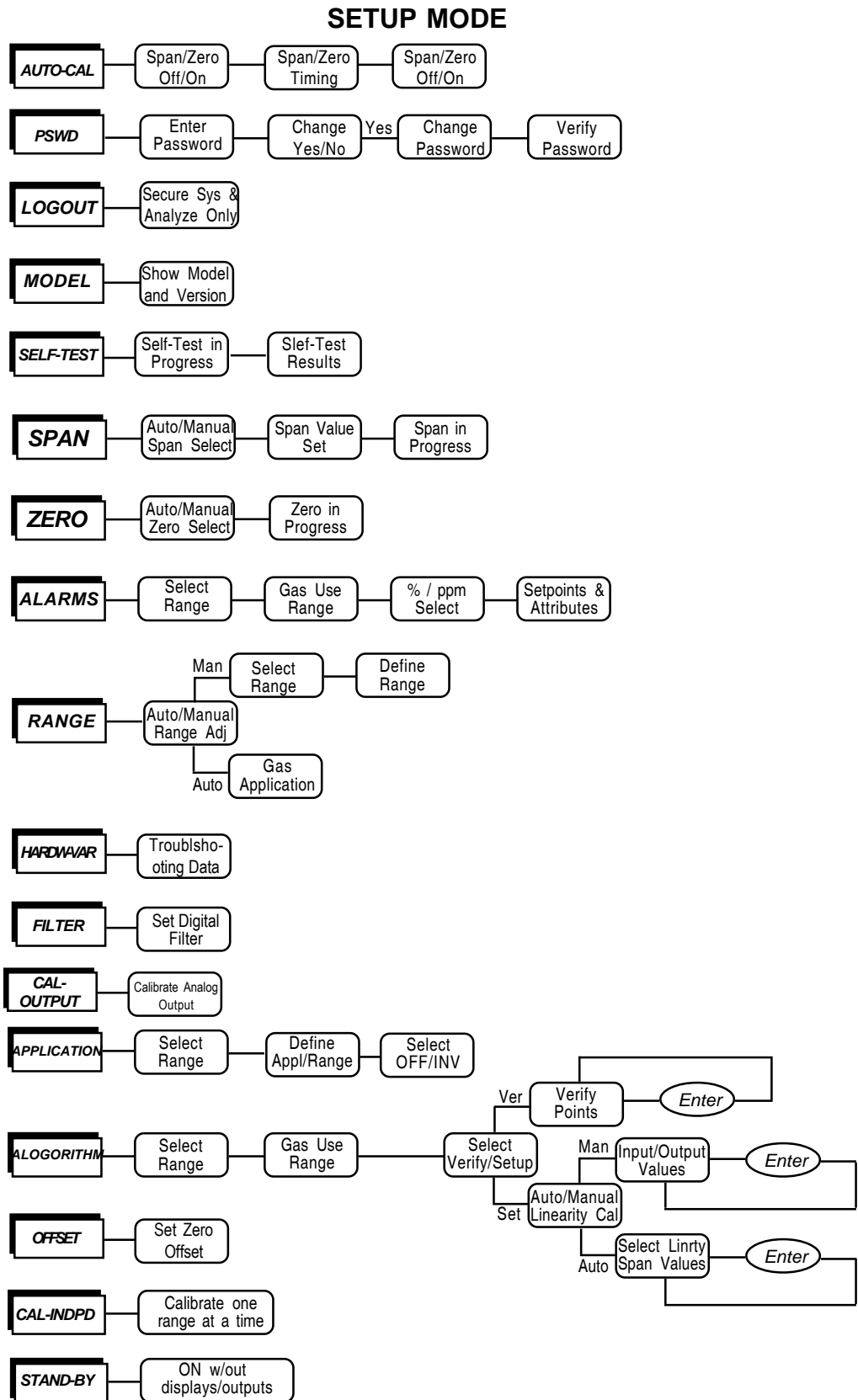

Figure 4-1: Hierarchy of Functions and Subfunctions

4.2.1.2 Setup Mode

The MAIN MENU consists of 14 functions you can use to customize and check the operation of the analyzer. Figure 4-1 shows the functions available with the 7100. They are listed here with brief descriptions:

- 1 **AUTO-CAL:** Used to define and/or start an automatic calibration sequence.
- 2 **PSWD:** Used to establish password protection or change the existing password.
- 3 **LOGOUT:** Logging out prevents unauthorized tampering with the analyzer settings.
- 4 **MODEL:** Displays Manufacturer, Model, and Software version of the instrument.
- 5 **SELF-TEST:** The instrument performs a self-diagnostic routine to check the integrity of the power supply, output boards, cell and amplifiers.
- 6 **SPAN:** Set up and/or start a span calibration.
- 7 **ZERO:** start a zero calibration.
- 8 **ALARMS:** Used to set the alarm setpoints and determine whether each alarm will be active or defeated, HI or LO acting, latching or not, and failsafe or not.
- 9 **RANGE:** Used to set up three analysis ranges that can be switched automatically with auto-ranging or used as individual fixed ranges.
- 10 **HARDW-VAR:** This function displays parameters used by the software for some calculations. It is a troubleshooting tool to be used by qualified technicians.
- 11 **FILTER:** This function sets the digital filter from 0 to 10, 0 being faster response time, and 10 being the slowest. The default is 4.
- 12 **CAL_OUTPUT:** Calibrate Analog Output
- 13 **APPLICATIONS:** Restricted function, not generally accessed by the end user. Used to define up to three analysis ranges and a calibration range (including impurity, background low end of range, high end of range, and % of ppm units).
- 14 **ALGORITHM:** A restricted function, not generally accessed by the end user. Used to linearize the output for the range of interest.

- 15 OFFSET: This function helps set a non-zero offset to the zero calibration. It is useful when zeroing the analyzer with a background gas that is different than the sample.
- 16 CAL-INDEPD: Not generally accessed buy the end user. Forces analyzer to be in independent calibration mode.
- 17 STANDBY: Remove power to outputs and displays, but maintain power to internal circuitry.

Any function can be selected at any time. Just scroll through the MAIN MENU with the DOWN/UP keys to the appropriate function, and ENTER it. The analyzer will immediately start that function, unless password restrictions have been assigned. (Password assignment is explained further on.)

All of these functions are described in greater detail in the procedures starting in section 4.3. The VFD screen texts used to illustrate the procedures are reproduced in a Monospaced type style.

4.2.2 Data Entry

4.2.2.1 ENTER

When the selected option is a function on the Main Menu screen, the function name appears between the arrows on the screen. You activate the function by the ENTER key.

When the selected option is a **function or subfunction**, ENTER moves the display to the VFD screen for that function or subfunction.

When the selected option is a **modifiable item**, the UP or DOWN keys can be used to increment or decrement that modifiable item to the value or action you want. Then you ENTER the item, which also puts you into the next field to continue programming.

When the last field is entered, ENTER takes you to the next screen in the process, or if the process is completed, ENTER takes you back to the ANALYZE screen.

4.2.2.2 ESCAPE

Pressing the ESCAPE key takes you back to the previous screen.

If you do not wish to continue a function, you can abort the session by escaping. Escaping a function takes the analyzer back to the previous screen, or to the ANALYZE Function, depending on the function escaped.

reproduced, at the appropriate point in the procedure, in a Mono-spaced type style. Push-button names are printed in *Oblique* type.

4.3.2 Setting up an AUTO-CAL

When proper automatic valving is connected (see chapter 3, *installation*), the Analyzer can cycle itself through a sequence of steps that automatically zero and span the instrument.

Note: Before setting up an AUTO-CAL, be sure you understand the *Zero* and *Span* functions as described in section 4.4, and follow the precautions given there.

Note: If you require highly accurate AUTO-CAL timing, use external AUTO-CAL control where possible. The internal clock in the Model 7100 is accurate to 2-3 %. Accordingly, internally scheduled calibrations can vary 2-3 % per day.

Note: If your ranges are configured for different applications, then AUTO-CAL will calibrate all of the ranges simultaneously (by calibrating the Cal Range).

To setup an AUTO-CAL cycle:

The VFD will display five subfunctions.

Call out MAIN MENU, scroll to AUTO-CAL function, and ENTER. A new screen for ZERO/SPAN set appears.

```
ZERO i n   0d  0h off
SPAN i n   0d  0h off
```

Use UP or DOWN key to blink ZERO (or SPAN), then *Enter*. (*You won't be able to set OFF to ON if a zero interval is entered.*) A Span Every ... (or Zero Every ...) screen appears.

```
Zero schedul e: OFF
Day:   0d Hour:   0h
```

Use UP or DOWN key to set a value in days, then ENTER to move to the start-time value in hours. Use **UP** or **DOWN** keys to set a start-time value, then ENTER.

To turn ON the SPAN and/or ZERO cycles (to activate AUTO-CAL): use UP or DOWN keys to set the OFF/ON field to ON. You can now turn these fields ON because there is a nonzero span time defined.

4.3.3 Password Protection

Before a unique password is assigned, the system assigns TAI by default. This password will be displayed automatically. The operator just presses the Enter key to be allowed total access to the instrument's features.

If a password is assigned, then setting the following system parameters can be done only after the password is entered: **alarm** setpoints, AUTO-CAL setup, ZERO/SPAN calibration assigning a new **password, range/application** selections, and **curve algorithm** linearization. (APPLICATION and ALGORITHM are covered in the programming section.) However, the instrument can still be used for analysis or for initiating a self-test without entering the password. To defeat security the password must be changed back to TAI.

NOTE: If you use password security, it is advisable to keep a copy of the password in a separate, safe location.

4.3.3.1 Entering the Password

To install a new password or change a previously installed password, you must key in and *ENTER* the old password first. If the default password is in effect, pressing the *ENTER* button will enter the default TAI password for you.

Call out MAIN MENU setup by selecting any controls

Use the UP or DOWN key to scroll the blinking over to PSWD, and press *Enter* to select the password function. Either the default TAI password or AAA place holders for an existing password will appear on screen depending on whether or not a password has been previously installed.

Enter password:
T A I

or

Enter password:
A A A

The screen prompts you to enter the current password. If you are not using password protection, press *Enter* to accept TAI as the default password. If a password has been previously installed, enter the password using the ENTER key to scroll through the letters, and the **UP** or **DOWN** key to change the letters to the proper password. The last ENTER enters the password.

In a few seconds, you will be given the opportunity to change this password or keep it and go on.

Change Password?
<ENT>=Yes <ESC>=No

Press *Escape* to move on, or proceed as in *Changing the Password*, below.

4.3.3.2 Installing or Changing the Password

If you want to install a password, or change an existing password, proceed as above in *Entering the Password*. When you are given the opportunity to change the password:

```
Change Password?
<ENT>=Yes   <ESC>=No
```

Enter to change the password (either the default TAI or the previously assigned password), or press *Escape* to keep the existing password and move on.

If you chose *Enter* to change the password, the password assignment screen appears.

```
Select new password
T A I
```

or

```
Select new password
AAA
```

Enter the password using the UP or DOWN keys and ENTER to scroll through the existing password letters, and the UP or DOWN keys to change the letters to the new password. The full set of 94 characters available for password use are shown in the table below.

Characters Available for Password Definition:

| | | | | | | | | | |
|---|---|---|---|---|----|---|---|---|---|
| A | B | C | D | E | F | G | H | I | J |
| K | L | M | N | O | P | Q | R | S | T |
| U | V | W | X | Y | Z | [| ¥ |] | ^ |
| _ | ` | a | b | c | d | e | f | g | h |
| i | j | k | l | m | n | o | p | q | r |
| s | t | u | v | w | x | y | z | { | |
| } | → | ! | " | # | \$ | % | & | ' | (|
|) | * | + | ' | - | . | / | 0 | 1 | 2 |
| 3 | 4 | 5 | 6 | 7 | 8 | 9 | : | ; | < |
| = | > | ? | @ | | | | | | |

When you have finished typing the new password, press *Enter*. A verification screen appears. The screen will prompt you to retype your password for verification.

Enter PWD To Verify:
A A A

Use the UP/DOWN key to retype your password and use ENTER to scroll through the letters, and last enter will complete verification. Your password will be stored in the microprocessor and the system will immediately switch to the *Analyze* screen, and you now have access to all instrument functions.

If all alarms are defeated, the *Analyze* screen appears as:

1. 95 % C02
nR1: 0 - 10 Anl z

If an alarm is tripped, the second line will change to show which alarm it is:

1. 95 % C02
AL-1

NOTE: If you log off the system using the LOGOUT function in the MAIN MENU, you will now be required to reenter the password to gain access to Alarm, and Range functions.

4.3.4 Logging Out

The LOGOUT function provides a convenient means of leaving the analyzer in a password protected mode without having to shut the instrument off. By entering LOGOUT, you effectively log off the instrument leaving the system protected against use until the password is reentered. To log out, scroll to field of LOGOUT function, and ENTER to log out. The screen will display the message:

Protected until
password entered

4.3.5 System Self-Diagnostic Test

The Model 7100 has a built-in self-diagnostic testing routine. Preprogramming signals are sent through the power supply, output board, preamp board and sensor circuit. The return signal is analyzed, and at the end of the test the status of each function is displayed on the screen, either as OK or as a number between 1 and 1024. (See *System Self Diagnostic Test* in chapter 5 for number code.) If any of the functions fails, the System Alarm is tripped.

Note: The sensor will always show failed unless identical gas is present in both channels at the time of the SELF-TEST.

The self diagnostics are run automatically by the analyzer whenever the instrument is turned on, but the test can also be run by the operator at will. To initiate a self diagnostic test during operation, use the UP/DOWN key to scroll through the MAIN MENU to the SELF-TEST and *Enter*. The screen will follow the running of the diagnostic.

```

RUNNING DIAGNOSTIC
Testing Preamp - Cell

```

When the testing is complete, the results are displayed.

```

Power: OK   Anal og: OK
Cell:    2   Preamp: 3

```

The module is functioning properly if it is followed by OK. A number indicates a problem in a specific area of the instrument. Refer to Chapter 5 *Maintenance and Troubleshooting* for number-code information. The results screen alternates for a time with:

```

Press Any Key
To Continue...

```

Then the analyzer returns to the initial System screen.

4.3.6 The Model Screen

Scroll through the MAIN MENU to MODEL and *Enter*. The screen displays the manufacturer, model, and software version information.

4.3.7 Checking Linearity with ALGORITHM

Use UP/DOWN control to select ALGORITHM, and *Enter*.

```

sel rng to set algo:
-> 01 02 03    <-

```

Use the UP/DOWN Control to select the range: 01, 02, or 03. Then press *Enter*.

```

Gas Use:    C02
Range:      0 - 10%

```

Enter again.

```

Algori thm setup:
VERI FY    SET UP

```

Use UP/DOWN key to select and *Enter* VERIFY to check whether the linearization has been accomplished satisfactorily.

```

Dpt  I NPUT  O U TPUT
  0   0. 00  0. 00

```

The leftmost digit (under Dpt) is the number of the data point being monitored. Use the UP/DOWN key to select the successive points.

The INPUT value is the input to the linearizer. It is the simulated output of the analyzer. **You do not need to actually flow gas.**

The OUTPUT value is the output of the linearizer. It should be the ACTUAL concentration of the span gas being simulated.

If the OUTPUT value shown is not correct, the linearization must be corrected. *ESCAPE* to return to the previous screen. Select and Enter SET UP to Calibration Mode screen.

```

Sel ect  al gori thm
      mode :  AUTO

```

There are two ways to linearize: AUTO and MANUAL. The auto mode requires as many calibration gases as there will be correction points along the curve. The user decides on the number of points, based on the precision required.

The manual mode only requires entering the values for each correction point into the microprocessor via the front panel buttons. Again, the number of points required is determined by the user.

4.3.8 Troubleshooting information

Accessing the HARDW_VAR function will allow a qualified technician to get further information on the health of the analyzer. This is a complimentary troubleshooting tool to SELF-TEST. Information displayed in the VFD display is shown below:

| | |
|---------------------|---|
| Calib_factor = 5.00 | (This is the slope calibration value of the span, default is 5.00) |
| AtoD_ave = 1289 | (This is the raw ADC count, -262144 to 262143 are acceptable raw counts but must still be evaluated by knowing what gas is flowing through the analyzer) |
| lOffset[r][g] = 492 | (This is the current zero offset from the zero calibration of the gain and range the instrument is on at the moment. It should be between 10,000 to 10,000) |

Hard_offset_C=3015 (This is the raw DAC count of the Coarse zero adjustment. It should read between 0 and 4095)

Hard_offset_F=2715 (This is the raw DAC count of the Fine zero adjustment. It should read between 0 and 4095)

Current_gain = 4 (This is the gain the analyzer is on, it should read between 0 and 9)

4.3.9 Digital Filter Setup

The 7100 analyzer has the option of decreasing or increasing the amount of filtering on the signal. This feature enhances the basic filtering done by the analog circuits by setting the amount of digital filtering effected by the microprocessor. To access the digital filter setup, scroll through the menu and select FILTER. Press the Enter key to see the following screen:

```
Enter Digital
Filter:    4
```

The number on the second row can be adjusted from 0, minimum digital filtering, to 10, maximum digital filtering. The default setting is 4 and that should suffice for most applications. In some applications where speeding the response time with some trade off in noise is of value, the operator could decrease the number of the digital filter. In applications where the signal is noisy, the operator could switch to a higher number; the response time is slowed down though.

10 to 90% response time on the different settings to a step input is shown below. This response time does not include the contributions of the bench sampling system and the preamplifier near the detector.

| Setting | 10-90% Response (seconds) |
|---------|------------------------------|
| 0 | 2.5 |
| 1 | 5 |
| 2 | 10 |
| 3 | 20 |
| 4 | 40 |
| 5 | 80 |

| | |
|----|------|
| 6 | 160 |
| 7 | 320 |
| 8 | 640 |
| 9 | 1280 |
| 10 | 2360 |

The response time listed above can and will change depending on the application and they merely serve to illustrate the effect of the digital filter. The digital filter disengages if there is an upset that is more than 5% of full scale. As the reading comes within the range, the filter becomes active once again.

4.3.10 Zero Offset Adjustment

The software in this instrument provides a way to enter an offset on the zero operation of the analyzer. If the background gas of the process is different than the zero calibration gas being used, the reading will have an offset that will be constant throughout its working range. Thus, the need to provide an offset when the instrument is being zeroed.

How to access the offset function:

To access this function, Scroll through the menu and select OFFSET. Press the Enter key to see the following screen:

Enter zero offset:
0.00 %

The offset value can be modified by using the Up/Down keys. Next section shows how to select this value. Suffice to say that whatever value you enter, will be automatically added to the reading. Thus, if you entered -0.10%, at the end of the zero the display will show -0.10%.

When the instrument enters the zero mode in AUTO, the instrument will do the work of bringing the reading back to zero plus the offset value that was entered. If you chose MANUAL zero mode, then you must adjust the zero of the instrument the corresponding section of the manual but with one difference: instead of bringing the display to read zero, you must make the display read zero plus the value entered as offset.

How the offset value is selected:

To find out what the offset value should be, the intended zero calibration gas and the mix of the process background gas must be procured. This of course assumes that the zero gas and the process background gas are very different and that an offset will occur.

1. Let the intended zero calibration gas flow through the 7100 sample cell (this assumes that you have started up your system as recommended by the manual or technical personnel) and do a zero on the instrument. Leave the offset set to zero value.
2. At the end of the zero function, make sure the analyzer reads zero.
3. Span the analyzer
4. Flow the process background gas mix through the 7100 sample cell on the Analyze mode. Wait for the reading to become stable. Write the reading down. Change the sign of the reading: This is the offset to be entered.
5. Do a manual run to check the analyzer operation. Reintroduce the zero calibration gas. Enter the zero Offset value as explained above.
6. Check that the instrument reads the entered offset.
7. Reintroduce the process background gas mix to the 7100 sample cell in the Analyze mode. It should read close to zero once the reading is stable ($\pm 1\%$ error of full scale).

Spanning the 7100:

Since the instrument might be spanned with a background gas the same as the zero calibration gas, the span value to be entered should be the span concentration plus the offset value (if the offset value has a minus sign then algebraically it becomes a subtraction).

4.3.11 CAL-OUT Function

Selecting the CAL-OUT function in menu makes possible to calibrate the output of the 4 to 20 mdc. In hardware terms, this function calibrates the Digital to Analog converter that feeds a signal to the 4 to 20 mdc E/I converter. Calibrating the 4 to 20 mdc output should be part of routine maintenance.

To calibrate the 4 to 20 mdc output, a calibrated multi-meter configured as an ammeter has to be connected to the analyzer to monitor the output. When ready, enter the CAL-OUT function. The following screen will be shown on the VFD display:

Adj st output to 4ma

<ENT> to OK: -7

Use the Up or Down key to adjust the number on the VFD display. The range of this number is from -255 to 255. As this number changes, so should the reading of the ammeter. Adjust this number until the reading of the ammeter is, as close as possible, 4.00 mADC. Press the enter to continue to the 20 mADC adjustment:

Adj st output to 20ma

<ENT> to OK: 5

Again, Use the Up or Down key to adjust this number until the ammeter reads, as close as possible, 20.0 mADC. Press the Enter key to continue to the NAMUR option.

NAMUR NE43 output?

<ENT> to OK: NO

The default setting is NO. That means the 4 to 20 mADC (and 0-1 vdc) are linear and show no discontinuities throughout its range of operation, approximately from 2.4 mADC to 21.6 mADC. If you switch it to YES by using Up or Down keys, the output of the 4 to 20 mADC will conform to NAMUR standard NE43. If selected, the output of the 2 to 20 mADC will exhibit a breakdown at readings below 3.8 mADC and above 20.5 mADC approximately. These breakdowns, indicate a failure on the analyzer. Please refer to the NAMUR NE43 standard for detailed information.

All the settings of this function are stored and are remembered after power loss. If instrument is cold started (returned to factory settings) the settings will be returned to 0 and non-NAMUR NE43 compliant.

NOTE: Analog 0-1 vdc output does not get calibrated when 4 to 20 mADC is adjusted, due to errors introduced by its own electronics.

4.4 The Zero and Span Functions

(1) The Model 7100 can have as many as three analysis ranges plus a special calibration range (Cal Range); and the analysis ranges, if more than one, may be programmed for separate or identical gas applications.

(2) If all ranges are for the same application, then you will not need the Cal Range. Calibrating any one of the ranges will automatically calibrate the others.

(3) If: a) each range is programmed for a different gas application, b) your sensor calibration has drifted less than 10 %, and c) your Cal Range was calibrated along with your other ranges when last calibrated, then you can use the Cal Range to calibrate all applications ranges at once.

If your Model 7100 analyzer fits the paragraph (3) description, above, use the Cal Range. If your analyzer has drifted more than 10 %, calibrate each range individually.

CAUTION: *Always allow 4-5 hours warm-up time before calibrating, if your analyzer has been disconnected from its power source. This does not apply if the analyzer was plugged in but was in STANDBY.*



The analyzer is calibrated using reference, zero, and span gases. Gas requirements are covered in detail in chapter 3, section 3.4 *Gas Connections*. Check that calibration gases are connected to the analyzer according to the instructions in section 3.4, observing all the prescribed precautions.

Note: **Shut off the gas pressure before connecting it to the analyzer, and be sure to limit pressure to 40 psig or less when turning it back on.**

Readjust the gas pressure into the analyzer until the flowrate through the sensor settles between 50 to 200 cc/min (approximately 0.1 to 0.4 scfh).

Note: **Always keep the zero calibration gases flow as close as the flowrate of sample gas as possible**

4.4.1 Zero Cal

The ZERO function in the MAIN MENU is used to enter the zero calibration function. Zero calibration can be performed in either the automatic or manual mode.

CAUTION: *If you are zeroing the Cal Range by itself (multiple application analyzers only), use manual mode zeroing.*



If you want to calibrate ALL of the ranges at once (multiple application analyzers only), use auto mode zeroing in the Cal Range.

Make sure the zero gas is flowing to the instrument. If you get a CELL CANNOT BE BALANCED message while zeroing skip to section 4.4.1.3.

4.4.1.1 Auto Mode Zeroing

Observe the precautions in sections 4.4 and 4.4.1, above. Scroll to ZERO function buy using UP/DOWN control and enter the zero function mode. The screen allows you to select whether the zero calibration is to be performed automatically or manually. Use the UP/DOWN key to toggle between AUTO and MAN zero settling. Stop when AUTO appears, blinking, on the display.

```
Select zero
mode: AUTO
```

Press *Enter* to begin zeroing.

```
####.## % C02
Slope=#.### C-Zero
```

The beginning zero level is shown in the upper left corner of the display. As the zero reading settles, the screen displays and updates information on Slope= in ppm/second (unless the Slope starts within the acceptable zero range and does not need to settle further). The system first does a course zero, shown in the lower right corner of the screen as C-Zero, for approximate 3 min, and then does a fine zero, and displays F-Zero, for approximate 3 min.

Then, and whenever Slope is less than 0.01 for at least 3 min, instead of Slope you will see a countdown: 9 Left, 8 Left, and so fourth. These are software steps in the zeroing process that the system must complete, AFTER settling, before it can go back to *Analyze*. Software zero is indicated by S-Zero in the lower right corner.

```
####.## % C02
4 Left=#.### S-Zero
```

The zeroing process will automatically conclude when the output is within the acceptable range for a good zero. Then the analyzer automatically returns to the *Analyze* mode.

4.4.1.2 Manual Mode Zeroing

Scroll to *Zero* and enter the *Zero* function. The screen that appears allows you to select between automatic or manual zero calibration. Use the UP/DOWN keys to toggle between AUTO and MAN zero settling. Stop when MANUAL appears, blinking, on the display.

```
Select zero
mode: MANUAL
```

Enter to begin the zero calibration. After a few seconds the first of three zeroing screens appears. The number in the upper left hand corner is the first-stage zero offset. The microprocessor samples the output at a predetermined rate.

```
####.##      %   CO2
Zero adj : 2048 C-Zero
```

The analyzer goes through C-Zero, F-Zero, and S-Zero. During C-Zero and F-Zero, use the UP/DOWN keys to adjust displayed Zero adj: value as close as possible to zero. Then, press *Enter*.

S-Zero starts. During S-Zero, the Microcontroller takes control as in *Auto Mode Zeroing*, above. It calculates the differences between successive samplings and displays the rate of change as Slope= a value in parts per million per second (ppm/s).

```
####.##      %   CO2
Slope=#.###   S-Zero
```

Generally, you have a good zero when Slope is less than 0.05 ppm/s for about 30 seconds.

Once zero settling completes, the information is stored in the analyzer's memory, and the instrument automatically returns to the *Analyze* mode.

4.4.1.3 Cell Failure

Cell failure in the 7100 is usually associated with inability to zero the instrument with a reasonable voltage differential across the Wheatstone bridge. If this should ever happen, the 7100 system alarm trips, and the VFD displays a failure message.

```
Cell cannot be balanced
Check your zero gas
```

Before replacing the sensor:

- a. Check your zero gas to make sure it is within specifications.

- b. Check for leaks downstream from the sensor, where contamination may be leaking into the system.
- c. Check flowmeter to ensure that the flow is no more than 200SCCM
- d. Check temperature controller board.
- e. Check gas temperature.

If none of the above as indicated, the sensor may need to be replaced. Check warranty, and contact Analytical Instruments Customer Service.

4.4.2 Span Cal

The *Span* button on the front panel is used to span calibrate the analyzer. Span calibration can be performed in either the automatic or manual mode.

CAUTION: If you are spanning the Cal Range by itself (multiple application analyzers only), use manual mode zeroing.



If you want to calibrate ALL of the ranges at once (multiple application analyzers only), use auto mode spanning in the Cal Range.

Make sure the span gas is flowing to the instrument.

4.4.2.1 Auto Mode Spanning

Observe all precautions in sections 4.4 and 4.4.2, above. Scroll SPAN and enter the span function. The screen that appears allows you to select whether the span calibration is to be performed automatically or manually. Use the UP/DOWN key to toggle between AUTO and MAN span settling. Stop when AUTO appears, blinking, on the display.

```
Select span
mode: AUTO
```

Enter to move to the next screen.

```
Span Val : 20.00 %
<ENT> To begin span
```

Use UP/DOWN key to change the span setting value.

ENTER will move the blinking field to units (%/ppm). Use UP/DOWN key to select the units, as necessary. When you have set the concentration of the span gas you are using, *Enter* to begin the Span calibration.

```
####.##%   C02
SI ope=#.###   Span
```

The beginning span value is shown in the upper left corner of the display. As the span reading settles, the screen displays and updates information on Slope. Spanning automatically ends when the span output corresponds, within tolerance, to the value of the span gas concentration. Then the instrument automatically returns to the analyze mode.

4.4.2.2 Manual Mode Spanning

Scroll Span by using UP/DOWN key and Enter to start the Span function. The screen that appears allows you to select whether the span calibration is to be performed automatically or manually.

```
Select span
mode: MANUAL
```

Use the UP/DOWN key to toggle between AUTO and MAN span setting. Stop when MAN appears, blinking, on the display. ENTER to move to next subfunction screen

```
Span Val : 20.00 %
<ENT> To begin span
```

Using the UP/DOWN key changes the span value, as necessary. *Enter* to move to the units field (%/ppm). Use UP/DOWN key to select unit.

Press *Enter* to enter the span value into the system and begin the span calibration.

Once the span has begun, the microprocessor samples the output at a predetermined rate. It calculates the difference between successive samplings and displays this difference as Slope on the screen. It takes several seconds for the first Slope value to display. Slope indicates rate of change of the Span reading. It is a sensitive indicator of stability.

```
####.##%   C02
SI ope=#.###   Span
```

When the Span value displayed on the screen is sufficiently stable, press *Enter*. (Generally, when the Span reading changes by 1 % or less of the range being calibrated for a period of ten minutes it is sufficiently stable.) Once *Enter*

is pressed, the Span reading changes to the correct value. The instrument then **automatically** enters the *Analyze* function.

4.5 The Alarms Function

The Model 7100 is equipped with 6 fully adjustable set points concentration with two alarms and a system failure alarm relay. Each alarm relay has a set of form "C" contacts rated for 3 amperes resistive load at 250 V ac. See Figure in Chapter 3, *Installation* and/or the Interconnection Diagram included at the back of this manual for relay terminal connections.

The system failure alarm has a fixed configuration described in chapter 3 *Installation*.

The concentration alarms can be configured from the front panel as either *high* or *low* alarms by the operator. The alarm modes can be set as *latching* or *non-latching*, and either *fail-safe* or *non-fail-safe*, or, they can be *defeated* altogether. The setpoints for the alarms are also established using this function.

Decide how your alarms should be configured. The choice will depend upon your process. Consider the following four points:

1. Which if any of the alarms are to be high alarms and which if any are to be low alarms?

Setting an alarm as HIGH triggers the alarm when the contaminant concentration rises above the setpoint. Setting an alarm as LOW triggers the alarm when the contaminant concentration falls below the setpoint.

Decide whether you want the alarms to be set as:

- Both high (high and high-high) alarms, or
- One high and one low alarm, or
- Both low (low and low-low) alarms.

2. Are either or both of the alarms to be configured as failsafe?

In failsafe mode, the alarm relay de-energizes in an alarm condition. For non-failsafe operation, the relay is energized in an alarm condition. You can set either or both of the concentration alarms to operate in failsafe or non-failsafe mode.

3. Are either of the alarms to be latching?

In latching mode, once the alarm or alarms trigger, they will remain in the alarm mode even if process conditions revert back to non-alarm conditions. This mode requires an alarm to be recognized before it can be reset. In the non-latching mode, the

alarm status will terminate when process conditions revert to non-alarm conditions.

4. Are either of the alarms to be defeated?

The defeat alarm mode is incorporated into the alarm circuit so that maintenance can be performed under conditions which would normally activate the alarms.

The defeat function can also be used to reset a latched alarm. (See procedures, below.)

If you are using password protection, you will need to enter your password to access the alarm functions. Follow the instructions in section 4.3.3 to enter your password. Once you have clearance to proceed, enter the *Alarm* function.

Note: If all ranges are for the same application, set any one of them will automatically set the others.

Press the *Alarm* button on the front panel to enter the *Alarm* function. Make sure that 01 is blinking.

```
Sel rng to set alm:
-> 01 02 03    <-
```

Set up the Range 1 alarm by moving the blinking over to 01 using the UP/DOWN arrow keys. Then *Enter*. Check the gas application and range limits as displayed on the screen.

```
Gas use: C02
Range:    0 - 10 %
```

Press enter again to set the alarm setpoints.

```
Sel %/ppm alm to set
AL1-PPM  AL2-PPM
```

Use the UP/DOWN keys to choose between % or ppm units. Then *Enter* to move to the next screen.

```
AL1: 1000 ppm HI
Dft:N  Fs:N  Ltch:N
```

Five parameters can be changed on this screen:

- Value of the alarm setpoint, AL1: #####
- Out-of-range direction, HI or LO
- Defeated? Dft:Y/N (Yes/No)
- Failsafe? Fs:Y/N (Yes/No)
- Latching? Ltch:Y/N (Yes/No).
- To define the setpoint, use the UP/DOWN key while screen is blinking over to AL1: #####. Use the UP/DOWN key to change

the number. Holding down the key speeds up the incrementing or decrementing.

- After the number (value) has been chosen, use Enter to move the desired parameter. Then use the UP/DOWN keys to change the parameter.
- Once the parameters for alarm have been set, Enter the alarm function again, and repeat this procedure for next alarm.
- To reset a latched alarm, go to Dft- and then use either UP two times or DOWN two times. (Toggle it to Y and then back to N.)

–OR –

Go to Ltch- and then use either UP two times or DOWN two times. (Toggle it to N and back to Y.)

4.6 The Range Select Function

The *Range* function allows you to manually select the concentration range of analysis (MANUAL), or to select automatic range switching (AUTO).

In the MANUAL screen, you are further allowed to define the high and low (concentration) limits of each Range, and select a single, fixed range to run.

CAUTION: *If this is a linearized application, the new range must be within the limits previously programmed using the System function, if linearization is to apply throughout the range. Furthermore, if the limits are too small a part (approx 10 % or less) of the originally linearized range, the linearization will be compromised.*



In the AUTO screen, you are further allowed to select which gas application (PREVIOUSLY defined in APPLICATION function) to run.

4.6.1 Manual (Select/Define Range) Screen

The Manual range-switching mode allows you to select a single, fixed analysis range. It then allows you to redefine the upper and lower limits, for the range.

Use UP/DOWN key to start the RANGE function, and ENTER

Select range
mode: MANUAL

Note: If all three ranges are currently defined for different application gases, then the above screen does not display (because mode must be manual). Instead, the VFD goes directly to the following screen.

If above screen displays, use the UP/DOWN arrow keys to Select MANUAL, and press *Enter*.

```
Select range to run
-> 01 02 03 CAL<-
```

Use the UP/DOWN keys to select the range: 01, 02, 03, or CAL. Then press *Enter*.

```
Gas use:    C02
Range:     0 - 10 %
```

Use the ENTER key to move the range to low-end field. Use ENTER key to move the range to high-end field. Use the UP/DOWN keys to change the values of the fields.

Press *Escape* to return to the previous screen to select or define another range.

Press *Enter* to return the to the *Analyze* function.

4.6.2 Auto Screen

Autoranging will automatically set to the application that has at least two range setup with the same gases.

In the autoranging mode, the microprocessor automatically responds to concentration changes by switching ranges for optimum readout sensitivity. If the upper limit of the operating range is reached, the instrument automatically shifts to the next higher range. If the concentration falls to below 85% of full scale of the next lower range, the instrument switches to the lower range. A corresponding shift in the DC concentration output, and in the range ID outputs, will be noticed.

The autoranging feature can be overridden so that analog output stays on a fixed range regardless of the contaminant concentration detected. If the concentration exceeds the upper limit of the range, the DC output will saturate at 1 V dc (20 mA at the current output).

However, the digital readout and the RS-232 output of the concentration are unaffected by the fixed range. They continue to read beyond the full-scale setting until amplifier saturation is reached. Below amplifier saturation, the over

range readings are accurate UNLESS the application uses linearization over the selected range.

The concentration ranges can be redefined using the *Range* function Manual screen, and the application gases can be redefined using the APPLICATION function, if they are not already defined as necessary.

CAUTION: Redefining applications or ranges might require re-linearization and/or recalibration.



To setup automatic ranging:

Select range on the MAIN MENU, and ENTER to start the Range function.

```
Select range
mode : AUTO
```

Note: If all three ranges are currently defined for different application gases, then the above screen does not display (because mode must be manual).

If above screen displays, use the UP/DOWN key to Select AUTO, and *Enter*.

Press *Escape* to return to the previous Analyze Function.

4.6.3 Precautions

The Model 7100 allows a great deal of flexibility in choosing ranges for automatic range switching. However, there are some pitfalls that are to be avoided.

Ranges that work well together are:

- Ranges that have the same lower limits but upper limits that differ by approximately an order of magnitude
- Ranges whose upper limits coincide with the lower limits of the next higher range
- Ranges where there is a gap between the upper limit of the range and the lower limit of the next higher range.

Range schemes that are to be avoided include:

- Ranges that overlap
- Ranges whose limits are entirely within the span of an adjoining range.

Figure 4-2 illustrates these schemes graphically.

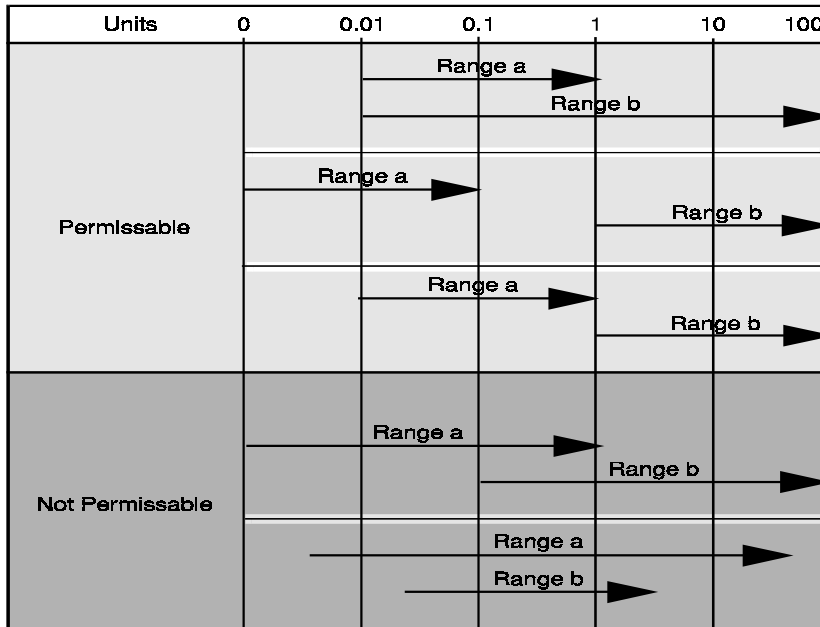

Figure 4-2: Examples of Autoranging Schemes

4.7 The Analyze Function

Normally, all of the functions automatically switch back to the *Analyze* function when they have completed their assigned operations. Pressing the *Escape* button in many cases also switches the analyzer back to the *Analyze* function. Alternatively, if you leave your analyzer on MAIN MENU screen within 5 seconds without touching any key, it will automatically return to analyze function. If the analyzer is in subfunction mode, in most cases, it will automatically return to analyze mode within 10 minutes.

The *Analyze* function screen shows the impurity concentration and the application gases in the first line, and the range in the second line. In the lower right corner, the abbreviation Anlz indicates that the analyzer is in the *Analyze* mode. If there is an * before the Anlz, it indicates that the range is linearized.

```
1.95 % C02
nR1: 0 -10 *Anl z
```

n indicates non inverting range
i indicates inverting range

If the concentration detected is over range, the first line of the display blinks continuously.

4.8 Programming

CAUTION: *The programming functions of the Set Range and Curve Algorithm screens are configured at the factory to the users application specification. These functions should only be reprogrammed by trained, qualified personnel.*



To program, you must:

1. Enter the password, if you are using the analyzer's password protection capability.
2. Connect a computer or computer terminal capable of sending an RS-232 signal to the analyzer RS-232 connector. (See chapter 3 *Installation* for details). Send the **rp** command to the analyzer.

Now you will be able to select the APPLICATION and ALGORITHM setup functions.

4.8.1 The Set Application Screen

The Set Application screen allows reprogramming of the three analysis ranges and the calibration range (including impurity gas, background gas, low end of range, high end of range, and % or ppm units). Original programming is usually done at the factory according to the customer's application. It must be done through the RS-232 port using a computer running a terminal emulation program.

Note: It is important to distinguish between this *System* programming subfunction and the *Range* button function, which is an operator control. The Set Range Screen of the *Application* function allows the user to DEFINE the upper and lower limits of a range AND the application of the range. The *Range* function only allows the user to select or define the limits, or to select the application, but not to define the application.

Normally the Model 7100 is factory set to default to manual range selection, unless it is ordered as a single-application multiple-range unit (in which case it defaults to autoranging). In either case, autoranging or manual range selection can be programmed by the user.

In the autoranging mode, the microprocessor automatically responds to concentration changes by switching ranges for optimum readout sensitivity. If the upper limit of the operating range is reached, the instrument automatically shifts to the next higher range. If the concentration falls to below 85% of full scale of the next lower range, the instrument switches to the lower range. A corresponding shift in the DC concentration output, and in the range ID outputs, will be noticed.

The autoranging feature can be overridden so that analog output stays on a fixed range regardless of the contaminant concentration detected. If the concentration exceeds the upper limit of the range, the DC output will saturate at 1 V dc (20 mA at the current output).

However, the digital readout and the RS-232 output of the concentration are unaffected by the fixed range. They continue to read beyond the full-scale setting until amplifier saturation is reached. Below amplifier saturation, the over range readings are accurate UNLESS the application uses linearization over the selected range.

To program the ranges, you must first perform the four steps indicated at the beginning of section 4.8 *Programming*. You will then be in the MAIN MENU and selecting application function screen.

```
Sel rng to set appl :
-> 01 02 03 CAL <-
```

Use the UP/DOWN key to increment/decrement the range number to 01, 02, 03, or CAL, and *Enter*.

```
Imp:   C02
FR: 0   TO: 10 %
```

Use the UP/DOWN key to increment the respective parameters as desired.

Use the ENTER to move from Imp: (impurity) to ppm or % to FR: (from-lower end of ranges), and TO: (to upper-end ranges).

Last *Enter* will accept the values and the screen will display

```
OFFST/INVRT:  <ENT>
Standard:     <ESC>
```

ESC if your application is standard. If your application requires OFFSET or Reversal output, ENTER will set your output as OFFSET or REVERSAL. (See special function setup section 4.9 for more information).

. (See note below.) Repeat for each range you want to set.

Note: The ranges must be increasing from low to high, for example, if Range 1 is set to 0–10 % and Range 2 is set to 0–100 %, then Range 3 cannot be set to 0–50 % since that makes Range 3 lower than Range 2.

Ranges, alarms, and spans are always set in either percent or ppm units, as selected by the operator, even though all concentration-data outputs change from ppm to percent when the concentration is above 9999 ppm.

Note: When performing analysis on a fixed range, if the concentration rises above the upper limit as established by the operator for that particular range, the output saturates at 1 V dc (or 20 mA). However, the digital readout and the RS-232 output continue to read regardless of the analog output range.

To end the session, send:

st<enter>

st<enter>

to the analyzer from the computer.

4.8.2 The Curve Algorithm Screen

The Curve Algorithm is a linearization method. It provides from 1 to 9 intermediate points between the ZERO and SPAN values, which can be normalized during calibration, to ensure a straight-line input/output transfer function through the analyzer. (*Before setting the alogorithm curve, each range must be Zeroed and Spanned*).

Each range is linearized individually, as necessary, since each range will usually have a totally different linearization requirement.

To linearize the ranges, you must first perform the four steps indicated at the beginning of section 4.8 *Programming*. You will then be in the MAIN MENU and select ALOGORITHM.

4.8.2.1 Checking the linearization

From the *MAIN MENU* screen, select ALGORITHM, and *Enter*.

```
Sel rng set al go
-> 01 02 03  <-
```

Use the UP/DOWN key to select the range: 01, 02, or 03. Then press *Enter*.

```
Gas use: CO2
Range: 0 -10 %
Enter agai n.
```

Algori thm setup:
VERI FY SETUP

UP/DOWN to select and *Enter* VERIFY to check whether the linearization has been accomplished satisfactorily.

| Dpt | I NPUT | O U TPUT |
|-----|--------|----------|
| 0 | 0. 00 | 0. 00 |

The leftmost digit (under Dpt) is the number of the data point being monitored. Use the UP/DOWN keys to select the successive points.

The INPUT value is the input to the linearizer. It is the simulated output of the analyzer. **You do not need to actually flow gas.**

The OUTPUT value is the output of the linearizer. It should be the ACTUAL concentration of the span gas being simulated.

If the OUTPUT value shown is not correct, the linearization must be corrected. *ESCAPE* to return to the previous screen. Select and Enter SET UP to Calibration Mode screen.

Sel ect al gori thm
mode : AUTO

There are two ways to linearize: AUTO and MANUAL: The auto mode requires as many calibration gases as there will be correction points along the curve. The user decides on the number of points, based on the precision required.

The manual mode only requires entering the values for each correction point into the microprocessor via the front panel buttons. Again, the number of points required is determined by the user.

Note: Before performing section 4.8.2 or 4.8.2.3, you must check to ensure that your calibration gases or points are between low end and high end of the range setup. All correction points must be between the Zero and the Span concentration. Do not enter the Zero and Span points as part of the correction

4.8.2.2 Manual Mode Linearization

To linearize manually, you must have previous knowledge of the nonlinear thermal-conductivity characteristics of your gases. You enter the value of the differential between the actual concentration and the apparent concentration (analyzer output). Analytical Instruments has tabular data of this type for a large number of gases, which it makes available to customers on request. See Appendix for ordering information. To enter data:

From the MAIN MENU Screen—

1. Use UP/DOWN to select ALGORITHM , and *Enter*.
2. Select and *Enter* SETUP.
3. Select MANUAL from the Calibration Mode Select screen.

| Dpt | INPUT | OUTPUT |
|-----|-------|--------|
| 1 | 0.00 | 0.00 |

The data entry screen resembles the verify screen, but the gas values can be modified and the data-point number cannot.

Use the UP/DOWN key to set the INPUT value for the lowest concentration into the first point. ENTER to move to OUTPUT field. Use the UP/DOWN key to set the OUTPUT value, the lowest concentration into the first point. ENTER to accept the first setting.

After each point is entered, the data-point number increments to the next point. Moving from the lowest to the highest concentration, use the UP/DOWN keys to set the proper values at each point.

| Dpt | INPUT | OUTPUT |
|-----|-------|--------|
| 0 | 0.00 | 0.00 |

Repeat the above procedure for each of the data points you are setting (up to nine points: 0-8). Set the points in unit increments. Do not skip numbers. The linearizer will automatically adjust for the number of points entered.

When you are done, *ESCAPE*. The message, Completed. Wait for calculation, appears briefly, and then the main *System* screen returns.

To end the session, send:

```
st<enter>
st<enter>
```

to the analyzer from the computer.

4.8.2.3 Auto Mode Linearization

To linearize in the Auto Mode, you must have on hand a separate calibration gas for each of the data points you are going use in your linearization. First, the analyzer is zeroed and spanned as usual. Then, each special calibration gas, for each of the intermediate calibration points, is flowed, in turn, through the sensor. As each gas flows, the differential value for that intermediate calibration point is entered from the front panel of the analyzer.

Note: The span gas use to span the analyzer must be >90% of the range being analyzed.

Before starting linearization, perform a standard calibration. See section 4.4. To enter data:

From the *MAIN MENU* screen—

1. Use UP/DOWN to select ALGORITHM , and *Enter*.
2. Select and *Enter* SETUP.
3. *Enter* AUTO from the Calibration Mode Select screen.

The Auto Linearize Mode data entry screen appears.

```

          1. 95 %   CO2
Input (Ø) : 2.00

```

5. Use the UP/DOWN keys to set the proper value of calibration gas, and *Enter*. Repeat this step for each cal-point number as it appears in the Input (x) parentheses.
6. Repeat step 5 for each of the special calibration gases, from the lowest to the highest concentrations. *Escape* when done.

To end the session, send:

```

st<enter>
st<enter>

```

to the analyzer from the computer.

4.9 Special Function Setup

CAUTION: *The programming functions of the output signal reversal, polarity reversal and gain preset are configured at the factory to the users application specification. These functions should only be reprogrammed by trained, qualified personnel.*



4.9.1 OFFSET OUTPUT/Reversal Output

4.9.1.1 Output Signal Reversal

Some applications require a reversal of the output signals in order for the 4-20mA and 0-1 V DC output signals to correspond with the low and high end of the concentration range. For example, if an application involves the analysis of 85-100% oxygen in a background of argon by measuring the thermal conduc-

tivity of the binary gas, the analyzer would normally be set up so that the 100% oxygen (0% argon) concentration would correspond to the zero level (4mA 0 V) of the output signal. Then, 85% oxygen (15% argon) would correspond to 20mA (1 V) in the signal output.

It may be convenient for the user to have the outputs reversed so that the 85-100% oxygen level outputs a 4-20mA (0-1 V) signal respectively. This can be accomplished by reversing the data input to the custom settings. Not all applications will require a reversing function, however, if this is desirable. This can be programmed by allowing the user to set the analyzer to read reversal output. Contact the factory for further information.

4.9.1.2 Output Signal Offset

TAI has provided the output offset feature in the software for the accuracy purpose. In many cases, the analyzer does not require this feature. For example, if the analyzer has setup to analyze the sample gas of 40-50% CO₂ in nitrogen, normally zero gas of this application requires 40% CO₂ in nitrogen. However, 100% of nitrogen can be used to zero the analyzer. In this case, the output offset is not needed to setup. For linear output the accuracy will access successfully within +/-1% off. But, if the application is analyzing the sample gas that is not linearly, the accuracy of the analyzer may not meet the specification. Therefore, output offset is required and 40% CO₂ in nitrogen is also needed for zero calibration gas.

To set up the output reversal or output offset, see section 4.8.1-set APPLICATION screen.

NOTE: If the inverting has been setup, “i” shall display on the left bottom corner. Otherwise, the left bottom corner display “n”.

NOTE: In the example 40% CO₂ in N₂ is discouraged, because it is hard to produce the exact concentration.

4.9.2 Polarity Reversal

In some special applications, user will find that the display displays negative concentration values, even if proper span gas is injected. For example, if application involves the analysis of 0-10% nitrogen in argon, and the reference chamber is sealed with air instead of argon, the microprocessor will be detecting signal and process assuming that the reference chamber is flowing with argon. However, in this case, the seal air reference that is compared to background of argon from the measurement chamber which has higher coefficient parameter and then will cause the analyzer to go negative. To correct this problem, TAI has added the Polarity Correction feature. This feature can be set as follow:

Close S1-5 range 1

Close S1-6 range 2

Close S1-7 range 3

Close S1-8 cal range

Select STANDBY to restart the system.

4.9.3 Gain Preset

NOTE: This function will apply only for the analyzer that has multiple range and non-linearity.

For nonlinear application, the signal produced by the infrared detector, will not correspond to the actual gas concentration. The amplification of each range will not agree, therefore, the gain must be preset in order for the signal to read linearly. To set the gain, the following must be performed in sequence.

NOTE: Before setting up this feature, you must have a span gas containing 90%-100% of the lowest range of the analyzer.

1. Set unit range to lowest range.

NOTE: For output reversal, the lowest range should be range 3, else the lowest range is range 1.

2. Connect span gas to span inlet.
3. Use UP/DOWN key to scroll to the CAL-INDEPD function.
4. Hold Escape/Enter control to ENTER position for approximately 10 seconds until the upper right connect display “ok” message.
5. Use UP/DOWN scroll to select SPAN function, then setup the setting to span level. Press ENTER key to span.

NOTE: You must do step #5 before the analyzer return to analyze mode. If the analyzer returns to analyze function, you must repeat step 3-5 again.

6. Set range to nex range’
7. Repeat steps 3-5 until you reach the last range of the row.

5.0 Maintenance

Aside from normal cleaning and checking for leaks at the gas connections, routine maintenance is limited to replacing filter elements and fuses, and recalibration.



WARNING: SEE WARNINGS ON THE TITLE PAGE OF THIS MANUAL.



5.0 Replacing the Fuse

Remove Power to Unit before replacing the fuse.

When a fuse blows, check first to determine the cause, then replace the fuse using the following procedure:

1. Disconnect the AC power and place the power switch located on the rear panel in the O position. Remove the power cord from the receptacle.
2. The fuse receptacle is located in the power cord receptacle assembly in the upper left-hand corner of the rear panel. See Figure 5-1

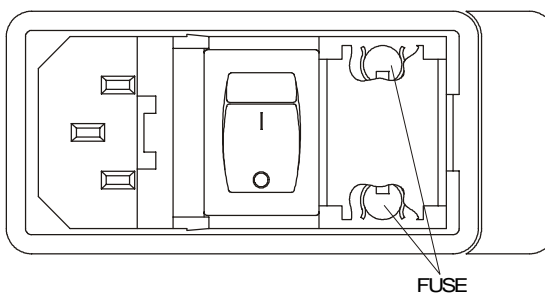

Figure 5-1: AC Fuse Replacement

3. Insert a small flat-blade screwdriver into the slot in the receptacle wall nearest the fuse and gently pry open the fuse receptacle. The fuse holder will slide out. There are two fuses in use and are visible in the clip.
4. Remove the bad fuse and replace it with a two 3 AGmm 1.0 A, 250 VAC, IEC time lag (T) fuse (P /N F9).
5. Replace the fuse holder into its receptacle, pushing in firmly until it clicks.

5.1 Routine Maintenance

The 7100 should be inspected on a regular schedule to be determined by the maintenance personnel. The system filter and analyzer measurement cell should be maintained as required by the quality of the sample.

Periodic calibration of the system will assure accurate analysis of the sample gas and will also indicate the need for maintenance. A regular calibration schedule should include recording of the zero and span pot values for performance trends. Clogging of the sample system and other system problems will usually show early symptoms during online analysis or during calibration.

Problems with the system not due to the normal processing of the sample are sometimes failures which must be corrected.

5.2 Filter

The system filter element (if included) should also be periodically inspected. Replacement is recommended when the element begins to restrict sample flow or upon visual inspection looks clogged and dirty.

NOTE: Although not normally included on basic Model 7120 analyzers, input protection filtering is always recommended. Refer to the system piping schematic for recommended hook-up.

5.3 NDIR Analyzer Measurement Cell

The Infrared Analyzer contains an auto zero circuit which automatically zeroes the analyzer. This zeroing compensates for dirt in the sample cell and, under normal circumstances, will compensate for very large amounts of contamination in the cell. If there is a need for removing the cell and cleaning it, follow this procedure:

A) Turn off power to the analyzer and open the optical bench housing. Disconnect the cell heater wires (if present).

B) Remove the cell assembly from the optical bench. Non-sealed cells can be swabbed with water and alcohol and dried thoroughly before reassembly. Sealed cells can be blown out with air, washed, or replaced.

C) After the cells have been cleaned and thoroughly dried, reassemble them into the optical bench. Also attach any disconnected wiring back onto the bench and check all connections and fasteners.

D) Turn on the analyzer and allow it to warm up for at least ten minutes. Check for zero and span gas response.

NOTE: Typically, sample cell should only be removed for cleaning when the Auto Zero circuit can no longer compensate for offset or if there is a loss of sensitivity caused by cell inefficiency.

5.4 System Self Diagnostic Test

1. Press the *System* button to enter the system mode.
2. Use the < > arrow keys to move to *More*, and press *Enter*.
3. Use the < > arrow keys to move to *Self-Test*, and press *Enter*.

The following failure codes apply:

Table 5-1: Self Test Failure Codes

Power

| | |
|---|-------------|
| 0 | OK |
| 1 | 5 V Failure |

- 2 15 V Failures
- 3 Both Failed

Analog

- 0 OK
- 1 DAC A (0–1 V Concentration)
- 2 DAC B (0–1 V Range ID)
- 3 Both Failed

Preamp

- 0 OK
- 1 Zero too high
- 2 Amplifier output doesn't match test input
- 3 Both Failed
- >3 Call factory for information (204 may some times appear even if call is ok. This might be when reference and sample gases are not the same)

Detector

- 0 OK
- 1 Failed (open filament, short to ground, no power.)
- 2 Unbalance (deterioration of filaments, blocked tube)

5.5 Major Internal Components

All internal components are accessed by unbolting and pulling open the rack assembly, removing the front cover, as described earlier. The major internal component locations are shown in Figure 5-3, the cell block is illustrated in Figures 5-2/5-3, and the fuse receptacle is shown in Figure 5-1.

The 7100 contains the following major internal components:

- Customer Interface PCB (Power Supply on bottom surface)
- Preamp PCB (Contains Microprocessor)
- Front Panel PCB (Contains Displays)
 - 5 digit LED meter
 - 2 line, 20 character, alphanumeric, VFD display

See the drawings in the Drawings section in back of this manual for details.

For Optical/Detector Alignments, refer to Optical Bench layout and circuit block diagrams below. Both beams (signals as combined on the detector from the collecting concave mirror in the detector housing, and viewed by an occilloscope-Refer to Optical Bench block diagram showing test points) must be balance properly, such that the energy levels obtained are evenly balanced. This is done by slight modification to the mechanical alignments between the source assembly, sample cell and detector housings.

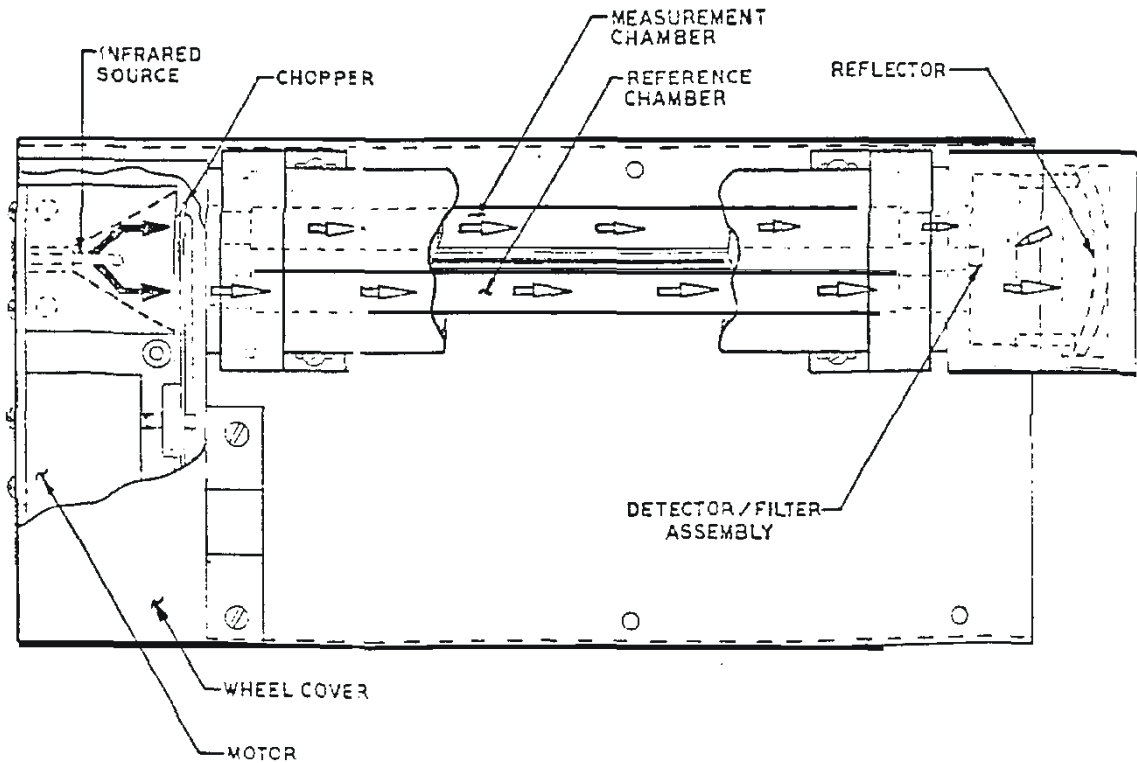

Figure 5-2: Cell Block

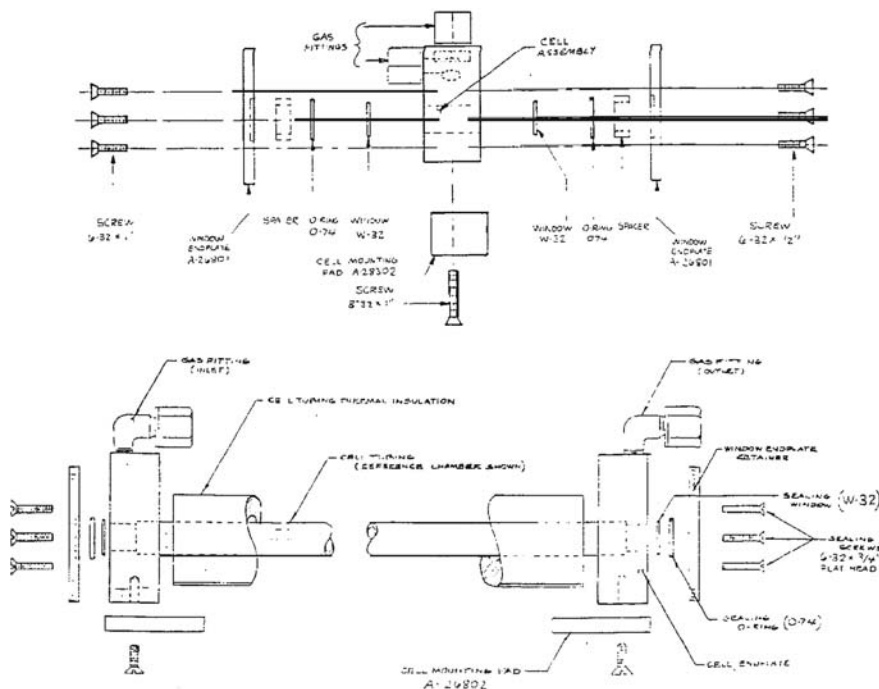

Figure 5-3: Cell Assembly

WARNING: HAZARDOUS VOLTAGES EXIST ON CERTAIN COMPONENTS INTERNALLY WHICH MAY PERSIST FOR A TIME EVEN AFTER THE POWER IS TURNED OFF AND DISCONNECTED.

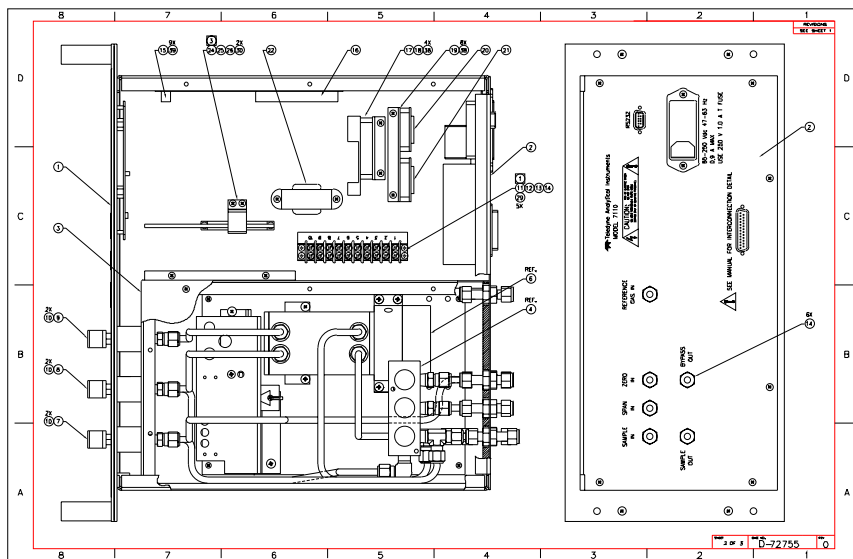

Figure 5-4: Major Internal Components

5.6 Troubleshooting

5.7 General

This section contains information on the assembly and the electronic sections of the Model 7100 Infrared Analyzer. The sample-handling sections of the system are statistically low failure items and only require the maintenance as pertinent to sample system operation (plugging, flowrates, leaks, etc.). Flow system “failures” are usually of the nature that are easily resolved by personnel familiar with basic mechanics of the Model 7100 flow system or sample system.

The electronic sections are more complex, requiring the assistance of personnel trained in electronics in the event of failure. The electronics sections of the analyzers include advanced solid-state and digital circuitry which requires a thorough understanding of circuit theory and troubleshooting techniques.

NOTE

It is recommended that only qualified electronic technicians troubleshoot electronic failures within the analyzers. Although both analyzers contain plug-in printed circuit panels, service personnel should be familiar both with the analyzer theory of operation and the basics of analog circuit theory before troubleshooting.

All basic customer electronic adjustments and calibrations of the analyzer can be accomplished with a DC volt-ohm meter (preferably with a digital readout). The analyzer contains AC waveforms which, only for failure-troubleshooting purposes, may be monitored by a medium bandwidth oscilloscope. All circuit boards are of the plug-in replaceable type and only require a DC voltmeter for set-up.

The following is a listing of parts needed for electronic calibration and troubleshooting of the analyzers:

- Accurate DC volt-ohm meter (digital readout) with clip-type leads
- Single-trace medium band width oscilloscope
- 15Åpin extender card (TAI P/N 9881)
- Miniature clip-type jumper leads (12" long)
- Small blade screwdriver (TAI P/N S-190)

5.8 TROUBLE SHOOTING CHART

| SYMPTOM | CORRECTIVE ACTION |
|---|---|
| <p>A. Unit does not turn ON when actuating Power Switch (Motor does not turn).</p> | <p>(a) Check AC voltage at inlet for correct voltage. Reset breaker or switch to supply power to receptacle.</p> <p>(b) Check power to terminal strip located inside cabinet. CAUTION: Terminal strip contains 90-220volt line voltage which can be hazardous. Check for loose connection to one of the terminal board lugs; replace as required.</p> |
| <p>B. No Zero Control (with unit on Zero gas). Output is either dead or fully saturated.</p> | <p>(a) Check that Power is ON and chopper motor energized.</p> <p>(b) Check that power supply voltages are correct (+15VDC, -15VDC).</p> <p>(c) Check output of TP6 on preamp board with a DC voltmeter (should be less than + or - 3VDC). If output can be zeroed, check voltages at TP1 and TP2 on Linearizer board (should also be zero). Then check adjustments on E/I board.</p> <p>(d) Check that infrared source is operating. If cold, check source element resistance and connections.</p> <p>(e) Check output of preamplifier</p> |

-
- (TPI) peak to peak voltage with high impedance oscilloscope if TP6 cannot be zeroed. If greatly out of balance, check for loose or dirty sample cell assembly.
- (f) Try to execute a manual zero.
- C. Meter reads Negative
(with zero gas flowing through analyzer)
- (a) ZERO control may be misadjusted.
Adjust control to bring indication up to zero. (refer to Section 4).
- (b) If zero indication unattainable with ZERO control centered, monitor TP6 on preamp board. If greater than + or - 3VDC, check waveforms at TPI for balance.
- (c) Check that infrared source is operating. If cold check source element resistance and connections.
- D. Meter Up Scale or Overscale
- (a) Redo full calibration.
- (b) Check for obstruction in sample beam path.
- (c) Check for excessive moisture in plumbing and sample chamber. Clean and replace sample chamber.
- E. Insufficient Span Control (with span gas)
- (a) Recheck zero for excessive offset; monitor TP6 of preamp board with zero gas and check for cell contamination.
- (b) Check modulation factor using certified span gas. Full scale concentration provides signal of 0-5 VDC at TPI of the Linearizer

Board. Insufficient signal can be due to misadjusted PI or sample system pressure fluctuations (vacuum).

F. Noisy or Erratic Operation

The most common sources of noises are:

(a) Reduced output of infrared source (5v, 110 ma each) or replace as necessary.

(b) Chopper hitting housing.

(c) Noisy detector.

(d) AC pickup at printed circuit board.

(e) Optical unit not grounded to cabinet.

(f) Detector connections loose.

(g) Faulty preamplifier board.

(h) Contamination in cell.

7120 Specifications

| % Range(s) | PPM Ranges |
|--|---|
| · 98-100% (CO ₂ purity) | 0-500 ppm H ₂ O _v in CL ₂ , N ₂ , CO or COC/2 |
| Other percent applications | Other ppm applications |
| · 95-100% CO in H ₂ , N ₂ , O ₂ | 0-1000ppm CO in flue gas |
| · 90-100% CH ₄ Purity | 0-500 ppm N ₂ O |
| · 0-1% H ₂ O _v in Air | 0-100ppm CO ₂ in Air |
| · 0-10% NH ₃ in Air | |
| · 0-100% CH ₄ in Natural gas | |
| · 0-10% CH ₄ in C ₂ ...C ₆ aliphatics | |

Above are typical percent and ppm ranges possible for a few sample gas applications.

Other ranges and gases possible with optical cell path/optical filter changes (consult factory).

Detector Type Lead salt as PbSe or PbS

Span Calibration

- Calibration can be done in many ranges: choose a typical 80% of range span gas.
Example: zero 99.995%CO₂; span 98.40% CO₂ in N₂
- Ultra pure Span calibration gas is recommended for purity applications.

Zero Calibration (Auto zero every 3 hours required)

- Ultra pure Zero calibration to be performed using 99.99%+ assay pure CO₂
- Flowing reference gas required at 20 ccm (purity must be same as ultra pure zero gas)
- Non-purity applications can use sealed air reference
- Zero gas from 0% level; use analyte free Air or N₂
- Span gas: use an 80 % full scale analyte in typically Air or N₂ for the pertinent range of interest.

Calibration offset capability for Auto Zero correction

· Dial-in offset manually to tune Cal gas to reference method

Example: Assay Cal Zero gas=99.99%; Zahm Nagel reference method=99.88%; offset correction = +0.11% CO₂

Accuracy on purity for CO₂ 98-100% range

· ± 3% of full scale or ± 0.06% CO₂

All other ranges for purity and non-purity applications

· ± 2% of full scale span

Repeatability · ± 1% of full scale

Resolution · 0.01 % to 0.1 depending upon full scale range used.

Linearity · < ±1% of full scale

Response Time · T₉₀ of < 30 seconds

- *Operating Temperature* 5° to 40° C (non-condensing)
- *inlet sample gas pressure* 2-3 psig, minimum, but controlled accurately
- *Cell pressure to be at 0 psig; vented to a very stable atmospheric pressure. Auto-span required with auto-zero if atmospheric pressure varies over time slowly.*
- *Cell calibration/process pressures up to 50 psig may be possible; vented to a very stable return pressure (< ±1% FS = < ± 0.07 psi; ± 0.005BAR)*
- *Connection, Inlet/Outlet Sample Gas* 1/4" tubing inlet/outlet fittings
- *Flow Rates:*
- Sample Gas* >0.4 and <2 SCFH recommended (~ 200 to 1000 ccm)
- Reference Gas* >0.04 and <0.2 SCFH recommended (>20 and <100 ccm)

| | |
|----------------------------|---|
| Mounting | 19" Panel/Rack mount |
| Envelope Dimensions | 19.0"W X 15.25"D X 8.75"H (482.6mmW X 387.45mmD X 222.25mmH) |
| Enclosure Rating | General Purpose |

AREA CLASSIFICATIONS

- *General Purpose*
- *Class I, Division II, B, C, D*

Characteristics

Panel mount

Analyzer may be Z-purged without temperature control in some applications. (Accuracy may be sacrificed, contact factory)

- *Class I, Division I, B, C, D* Analyzer may be X-purged without temperature control in some applications. (Accuracy may be sacrificed, contact factory)
- *Class I, Division I, B, C, D* Split architecture, Bulk mounted encl's

ELECTRICAL/ELECTRONICS SPECIFICATIONS

Features:

Output (4-20 mA iso; 0-1v DC analog), RS-232 digital
Maximum load Impedance for 4 – 20 mA output 1,000 Ohms (@ 24 VDC min.)

Voltage Requirements:

110 VAC or 220 VAC; 50/60 Hz (specify at time of order)

Display: 5 digit LED display and 2x20 VFD display

Customer Interface: Membrane key pad (manual)

Enter and Escape keys

Arrow Up / Down adjustment

Alarms: Two fully programable Alarms

Drawing List

D-72052 Outline Diagram

B-72774 Piping Diagram

D-72771 Wiring Diagram

D-67447 Schematics Diagram

D-72759 Schematics Diagram

D-62370 Schematics Diagram

D-65506 Schematics Diagram

C-72761 Schematics Diagram

A-30943 Schematics Diagram

D-69534 Schematics Diagram

A-72757 Schematics Diagram

Recommended 2-Year Spare Parts List

NOTE: *Part list may or not be part of your system, due to the wide range of applications implicated.*

| Qty | P/N | Description |
|-----|----------|------------------------------|
| 1 | C-67435B | Main CPU PCB Assy |
| 1 | C-72760 | Preamp PCB Assy |
| 1 | C-62371B | Display PCB Assy |
| 1 | C72863 | Back Panel PCB Assy |
| 1 | C72758 | Preamp Filter PCB Assy |
| 1 | B30900 | Motor PS PCB Assy |
| 1 | C69535A | Temperature Control PCB Assy |
| 1 | B72756 | Source PS PCB Assy |
| 2 | B58206 | Source Lamp Assy |
| 4 | O158 | O-ring |
| 4 | W32 | Window |
| 2 | F68 | Fuse |
| 1 | A-39220 | CHOPPER MOTOR |
| 1 | T-358 | THERMOSWITCH |
| 1 | R-179 | RELAY (FOR ALARM) |
| 1 | A-16776 | ACCESSORY KIT |

Note: Orders for replacement parts should include the part number (if available) and the model and serial number of the instrument for which the parts are intended.

Orders should be sent to:

TELEDYNE Analytical Instruments

16830 Chestnut Street
City of Industry, CA 91749-1580

Phone (626) 934-1500, Fax (626) 961-2538
TWX (910) 584-1887 TDYANYL COID

Web: www.teledyne-ai.com

or your local representative.

ATTACHMENT 7120**Quote "Exceptions" and "GAS PHASE Conditions" for this application:**

- 1 Response Time is proportional to sample system design for take-off distance, process pressure, line size, by-pass flow design, dead-volumes/tee's, sample cell volume and instrument electronics.
- 2 We assume no particulates that could plug the lines or contaminate the optical components.
- 3 Control the pressure in the measuring sample cell to within 0.5 % of the nominal operating cell pressure (for example: 760 mm \pm 4 mm Hg absolute) is required, return pressure assume to be stable at 1 ATM A. **Maximum cell operation pressure to be 5 psig** based upon standard metal/sapphire cell design.
- 4 The sample flow through the analyzer should be regulated to within \pm 5% of its recommended absolute nominal set point flow value. This will avoid any pressure drops across any orifices.
- 5 The temperature of the sample from the take-off thorough the sample cell must be maintained above its dew point to prevent any moisture or (vapor pressure) for other possible condensables/mists from occurring and affecting instrument performance. (Loss of CO₂ or other soluble gases)
- 6 The sample temperature should not vary at the inlet more than \pm 15 °C of the calibration temperature, nor exceed the design operating specifications typically 1-50 °C.
- 7 Any background components later found to be present and not specified in the original application feasibility may void the instrument performance should they interfere.
For CO₂ the impurity of N₂O will interfere. Assume no others at measuring wavelength.
- 8 We recommend when ambient temperatures exceed outside a 5-45°C range that the instrument and sample system be conditioned appropriately for heating/ cooling without condensation.
- 9 Should the general purpose or explosion proof instrument be supplied on a back-panel or as a bulk-mount housing, the customer must install to protect the instrument to meet harsh ambient conditions for dust, water, snow, wind, corrosion, etc.

- 10 If condensables occur, such as moisture, acid gases, solvents, etc., sample system materials may be compromised for corrosion resistance integrity. Special materials may be required.
- 11 Teledyne is not responsible for applying a general purpose instrument in a hazardous area or where a flammable gas is brought to an analyzer above its lower explosive limit and the area has been classified as general purpose.
- 12 Customer must supply the necessary calibration gases at the required purities.
- 13 Customer must auto zero and span calibrate as specified in the compliance sheet.

