

---

# Models 326, 7, & 8 Oxygen Analyzers

## Instruction Manual

P/N M33776  
6/29/95

---

## Notice

Important safety information is to be found on the following page, under the title ***Important Notice***, and on the last three pages of this manual under the title ***Material Safety Data***. Be sure all personnel involved in the installation and operation of this equipment understand this information and are impressed with its importance.

## Note

Specific Application Information for the instrument with which this manual is supplied is on page iv just prior to the Table of Contents.

---

**Copyright © 1994 Teledyne Analytical Instruments**  
**All Rights Reserved**

No part of this manual may be reproduced, transmitted, transcribed, stored in a retrieval system, or translated into any other language or computer language in whole or in part, in any form or by any means, whether it be electronic, mechanical, magnetic, optical, manual, or otherwise, without the prior written consent of Teledyne Brown Engineering Analytical Instruments, 16830 Chestnut Street, City of Industry, CA 91749-1580.

**Warranty**

This equipment is sold subject to the mutual agreement that it is warranted by us free from defects of material and of construction, and that our liability shall be limited to replacing or repairing at our factory (without charge, except for transportation), or at customer plant at our option, any material or construction in which defects become apparent within one year from the date of shipment, except in cases where quotations or acknowledgments provide for a shorter period. Components manufactured by others bear the warranty of their manufacturer. This warranty does not cover defects caused by wear, accident, misuse, neglect or repairs other than those performed by Teledyne or an authorized service center. We assume no liability for direct or indirect damages of any kind and the purchaser by the acceptance of the equipment will assume all liability for any damage which may result from its use or misuse.

We reserve the right to employ any suitable material in the manufacture of our apparatus, and to make any alterations in the dimensions, shape or weight of any parts, in so far as such alterations do not adversely affect our warranty.

**Important Notice**

This instrument provides measurement readings to its user, and serves as a tool by which valuable data can be gathered. The information provided by the instrument may assist the user in eliminating potential hazards caused by his process; however, it is essential that all personnel involved in the use of the instrument or its interface, with the process being measured, be properly trained in the process itself, as well as all instrumentation related to it.

The safety of personnel is ultimately the responsibility of those who control process conditions. While this instrument may be able to provide early warning of imminent danger, it has no control over process conditions, and it can be misused. In particular, any alarm or control systems installed must be tested and understood, both as to how they operate and as to how they can be defeated. Any safeguards required such as locks, labels, or redundancy, must be provided by the user or specifically requested of Teledyne at the time the order is placed.

Therefore, the purchaser must be aware of the hazardous process conditions. The purchaser is responsible for the training of personnel, for providing hazard warning methods and instrumentation per the appropriate standards, and for ensuring that hazard warning devices and instrumentation are maintained and operated properly.

Teledyne Analytical Instruments (TAI), the manufacturer of this instrument, cannot accept responsibility for conditions beyond its knowledge and control. No statement expressed or implied by this document or any information disseminated by the manufacturer or its agents, is to be construed as a warranty of adequate safety control under the user's process conditions.

---

## Specific Application Data

TAI Sales Order Number:

Customer Order Number:

Instrument Model Number:

Instrument Serial Number:

Micro-Fuel Cell Class:

Accuracy:

Response and Recovery:

Operating Temperature Range:

Range of Analysis:

Output Signal Voltage:

Output Signal Current:

Alarm Setpoint #1:

Alarm Setpoint #2:

Special Features (may be covered by addendum.):

---

## Table of Content

---

1	Introduction	
1.0	Series Description .....	1-1
1.1	Model Designations .....	1-2
1.2	Models 326R Description .....	1-2
1.3	Models 327R Description .....	1-3
1.4	Models 327RAC/RBC Description .....	1-3
1.5	Models 328R Description .....	1-4
1.6		
2	Operational Theory	
2.1	Principles of Operation .....	2.1
2.1.1	Micro-Fuel Cell Sensor .....	2.3
2.1.2	Sample System .....	2.3
2.1.3	Electronics and Signal Processing .....	2.5
3	Operations	
3.1	Front Panel Controls .....	3.1
3.2	Modes of Operation .....	3.2
	Cold Start-Up .....	3.5
	Calibration Zeroing .....	3.6
	Calibration Using Span Gas .....	3.8
	Select Active Sensor .....	3.11
	Install Sensor and Test Alternate Sensor .....	3.12
	O <sub>2</sub> Range Set-Up .....	3.14
	Set-up Alarms .....	3.15
	Logger Set-Up .....	3.17
	Set-Up Clock Functions .....	3.19
	Changing Passwords For Remote Monitoring and Control .....	3.21
	System Statistics .....	3.23

---

4 Installation	
4.1 Unpacking the Analyzer .....	4.1
4.2 Micro-Fuel Cell Installation or Replacement .....	4.2
4.3 Electrical Connections .....	4.2
Front Panel .....	4.4
Rear Panel .....	4.4
Voltage Selection .....	4.6
Fuse Changing .....	4.7
Parallel and Serial Ports .....	4.8
4.4 Gas Line Connections .....	4.9
4.5 Installation Checklist .....	4.10
5 Maintenance & Troubleshooting	
5.1 Routine Maintenance .....	5.1
5.2 Troubleshooting .....	5.2
Appendices	
A.1 Specifications Sheet .....	A.1
A.2 Spare Parts List .....	A.3
A.3 Material Safety Data Sheet .....	A.4

---

## Introduction

---

The Teledyne Analytical Instruments (TAI) Model 326 series (Models 326, 327, and 328) analyzers use a unique Micro-Fuel Cell to measure the concentration of oxygen in a gas stream. The analyzer can be housed in a compact equipment case, a 19-inch rack mount unit, an explosion-proof bulkhead-mounted enclosure, or separately from the panel-mounted control unit.

The Micro-Fuel Cell (U.S. Patent No. 3,429,796) is a maintenance-free, disposable, solid-state unit whose performance and usable life are guaranteed by TAI. The cell consumes oxygen from the gas around it and generates a proportional microampere current. The low level signal is then amplified by a solid-state, integrated circuit (IC) amplifier. The resulting DC signal drives a temperature compensation circuit for the cell, and an integral meter. The output signal is available at the analyzers terminal strip and is linear over the specified ranges of analysis. It is suitable for driving a high-impedance recording device.

The Micro-Fuel Cell responds accurately to the presence of oxygen, regardless of flowrate. The measuring cell does not generate an output current unless oxygen is present in the sample gas. Therefore, the instrument has an absolute zero, and no zero gas is required to standardize the analyzer. The analyzer can be calibrated using atmospheric air as a span gas, providing one of the three ranges of analysis encompasses the oxygen content of air.

The Model 326 series analyzers have three standard ranges: 0–5 % O<sub>2</sub>, 0–10 % O<sub>2</sub>, and 0–25 % O<sub>2</sub>.

In some instances an outer enclosure may contain the analyzer and other related devices, such as sample system components or other analyzers. These special designs are supported by special drawings included with the standard drawings at the rear of the instruction manual. Use those drawings in conjunction with the standard drawings, and note any differences.

Specific models in the 326 series are described in the following paragraphs. Be sure to read the description of the model you have purchased.

See *Specific Application Information* for your instrument in front of the Table of Contents.

### **1.1 Model Designation**

The basic model number of each of the analyzers (326, 327, and 328) has a suffix that describes the options included. Suffixes for the standard options are listed below.

- R: Electronic motherboard designed with receptacles for standardized plug-in support circuitry, such as linearized or custom output modules.
- A: Panel mount
- B: Bulkhead mount
- O: Isolated current output
- 2: Dual alarm setpoint
- X: Special configuration as specified at the time of order.
- C: CENELEC (Comité Européen de Normalisation Electrotechnique) version.

### **1.2 Models 326R Description**

The Model 326R is a general purpose version designed for use in non-hazardous areas. The electronics circuits, Micro-Fuel Cell, and other sample handling components are all packaged as a single unit. In some applications, such as the Model 9150 Flue Gas system, the immediate enclosure may not be used, since the entire system is housed in a system enclosure. In those cases the electronics are mounted upon a backplate, rather than within the Model 326 enclosure.

Mounting styles for the analyzer include panel mount (Model 326RA), surface or bulkhead mount (Model 326RB), and bulkhead mount NEMA-4 (Model 326RBN). Though the physical appearance differs according to the mounting style, analyzer functions are the same.

Sample flow controls for the Model 326R are mounted on a gas selector panel below or to the right of the front panel. Electrical controls and terminal strip are accessible from the back of the analyzer in the 326RA and behind the front panel, which swings open, in the 326RB. The sensor is located behind the door on the front panel of the analyzer. The flow rate is displayed by a flowmeter, which is mounted on, to the right of, or behind the control panel. In other cases, a separate panel may be used to contain valves for sample selection and flow control. When the analyzer is used as part of a system, various means of sample handling may be used. A piping

diagram is then included with the drawings in the instruction manual to illustrate the sample flow path.

### 1.3 Models 327R Description

Model 327R is a semi-explosion-proof version of the 326R series. The specific explosion-proof design is dependent on area classification and the specific installation. For example, the analysis section of the 327R containing the Micro-Fuel Cell, and related conditioning components, can be housed in an explosion-proof enclosure. If the sensor is placed within the process or in a flow-through block, such that the explosion-proof classification is maintained, then no analysis section enclosure may be necessary.

The standard Model 327R analysis section is a bulkhead-mounted, cast aluminum enclosure with a screw-on cover, and is separate from the control unit, which can be either panel mounted (327RA) or bulkhead mounted (327RB). The sensor and the electrical interconnections are accessed by removing the cover on the explosion-proof analysis section. Interconnecting wiring is fed through sealed fittings in the wall of the enclosure. A sample/calibrate selector valve and a flow control/flow meter are normally attached to the outer right-hand wall of the enclosure. The entire analysis section conforms to the area classification specified at the time of purchase (usually Class I, Div. I, Group D).

The control unit is designed for remote mounting in nonhazardous areas and is basically the same control unit as is used for the Model 326R, except that the measuring cell and related sample handling components are placed in the analysis section. Panel mount (327RA) and bulkhead mount (327RB) styles are available for the control unit.

### 1.4 Models 327RAC/327RBC Description

The 327RAC and 327RBC models have separate control, analysis, and probe units. The analysis units can be controlled remotely.

In models approved by CENELEC (Comité Européen de Normalisation Electronique), safety-barrier boxes isolate the probes from the control units, making them intrinsically safe. In addition, the probes are approved by BASEEFA (British Approvals Service for Electrical Equipment in Flammable Atmospheres).

The control unit of the 327RAC/RBC has an integral meter, power on-off switch and range switch, protective fuses, sample path selection capability, calibration (span) control, and the various plug-in printed circuit boards

used to provide both the optional circuitry and the standard electronics features of the analyzer.

### 1.5 Models 328R Description

Model 328R is a fully explosion-proof version of the Model 326R and is completely contained in one or more explosion-proof enclosures as needed to house the specific components used. Since both the electronics control and the sample analysis sections of the analyzer must meet hazardous area classification, they are normally enclosed in a single enclosure and fitted with explosion-proof operators for switches and potentiometers. These protrude through the sealed enclosure, which also has a viewing window to allow observation of the measurement meter.

A commonly used option with the Model 328R is the gas selector panel. The panel provides selection and flow control of sample or span gas. Sealed connectors carry the selected gas to the measuring cell inside the explosion-proof instrument enclosure.

### 1.6 Models 328RC Description

The Model 328RC Trace Oxygen Analyzer was designed to meet CENELEC operating standards for European use.

The Model 328RC is housed in an explosion-proof enclosure with a BASEEFA EExdIIBT6 rating. So that the explosion-proof enclosure does not have to be opened, the span adjustment, range selection, and alarm setpoint controls are placed on the exterior of the enclosure.

The analyzer has a separate probe that is attached to a control unit. The control unit contains safety barriers (see Chapter 2 for more information).

**Note: If installed, safety barriers should always be used. It is the user's responsibility for installing the probe in an appropriate sample system and protecting it from environmental factors such as temperature and RFI.**

The Model 328RC contains modular plug-in-type printed circuit boards (PCB) for temperature regulation, voltage-to-current conversion, comparator alarms, power supplies, and oxygen amplifier circuit. The plug-in PCBs greatly enhance troubleshooting and repair, since entire circuits can be stocked as spare parts.

Some of the PCBs contain calibration adjustments, which are shown on the board schematics. For example, the meter is adjusted with a potentiometer on the motherboard.

**Note: Before supplying power to the analyzer, be sure to check the wiring**

against the interconnection diagram.

## 1.7 Standard Features

The following features apply to the standard 326 series analyzers. Since *design features do vary in accordance with customer requirements, check the Specific Application Information, and any addendums* included in this manual, where the distinctive features of your instrument are recorded.

### 1.7.1 Ranges of Analysis

The ranges of analysis for standard instruments are 0-5 %, 0-10 %, and 0-25 % oxygen. A rotary switch on the control panel is used to select the desired analysis range. The standard instrument ranges have been chosen to best cover the oxygen content of flue gas. Upon request at the time the order is placed, any range or ranges of analysis from 0-1 % up to 0-100 % oxygen can be provided.

The oxygen content of atmospheric air (20.9 %) falls within the 0-25 % range. It is recommended for calibration because it eliminates the need for a span gas. Note, however, that a span gas is required, if the air around the analysis unit cannot be used to span the instrument (as in hazardous locations), or if an instrument is ordered without the 0-25 % calibration range.

### 1.7.2 Meter Readout

Standard models are equipped with an accurate ( $\pm 1/2$  % linearity) 3-inch analog meter calibrated to show the concentration of the target gas in the sample. A linear scale provides reliable, accurate readout of the analysis at any point on the scale. The resolution and accuracy of the meter eliminates the necessity of an accessory readout device, unless permanent recording or remote indication is required. Digital panel meters are used when requested by the customer.

### 1.7.3 Output Signal

For those applications requiring a remote indication and/or recording of the sample oxygen, a linear output signal of 0–1 V dc is available at no extra charge. Unless otherwise specified, the output signal will be 0–1 V dc .

The standard voltage output signal is not suitable for driving low impedance devices. Accessory equipment must have an input impedance of 10,000 ohms or more. Refer to the Current Output (E to I Converter) section later in this chapter for information on that option.

### **1.7.4 Temperature Control and Compensation**

Inaccuracies caused by varying temperature conditions are inherent in most methods of analysis employing transducers. To correct for this, a system composed of a combination of temperature compensation and control is used in the 326 series.

To protect the Micro-Fuel Cell against damage from low ambient temperatures and reduce the range required for the compensation circuit, the analyzer is equipped with a thermostatically controlled heating system that will not permit the interior of the instrument to drop below 70 °F.

To eliminate the inaccuracies accompanying the positive temperature coefficient of the Micro-Fuel Cell, a specially selected thermistor and network of precision resistors is utilized to produce a negative coefficient of matching characteristics. The variable element (thermistor) in the compensation network is physically located in the same assembly as the Micro-Fuel Cell, so that both devices are exposed to essentially the same temperature conditions.

Compensation techniques for high temperature conditions (up to 125 °F), allow the user to disturb the integrity of the analyzer (by opening the door or front panel) without the equalibration time that would normally accompany systems employing only high temperature control. In addition, the life of the Micro-Fuel Cell is extended by not subjecting it to the high ambient temperature that would be required in an exclusively temperature-controlled system.

### **1.7.5 Modular Electronics**

The electronic components are mounted on a plug-in printed circuit board, as are the various optional electronic features, for fast, simple repair. Although circuit failure is unlikely, plug-in capability of the critical elements of the circuit facilitates instant solution in the event of a semiconductor failure—providing the customer backs up his instrument with the recommended spare. The faulty circuit board may then be returned to the factory for repairs. Having an available spare part is usually more economical than the services of highly trained service personnel. The printed circuit assemblies are preset and adjusted to be instantly interchanged.

### **1.8 Optional Features**

The following optional features are only available at the time the order is placed.

### 1.5.1 Integral Alarm Circuitry

A number -1 or -2 appended to the model number indicates one or two alarm and/or control relay circuits with setpoints that are adjustable over the selected analysis range. The contacts of the relay are available for interconnection with customer circuitry at the terminal strip provided.

The setpoint is set by a potentiometer with a calibrated-dial. The integral control circuitry can be arranged so that the relay is energized above or below the setpoint. Unless otherwise specified, the control relay in a single setpoint instrument actuates (de-energizes) when the oxygen concentration rises above the setpoint, and the relays in a double setpoint instrument actuate (de-energize) when the oxygen level is outside the portion of the analysis range between the two setpoints. These configurations can be used for power supply failure alarms as well as an oxygen alarm. The Form "C" relay contacts are rated at 3 A (noninductive).

### 1.8.2 E to I Converter

TBE also offers a current output signal, so that current-to-pneumatic devices, as well as low impedance current indicating and/or recording equipment, may be driven directly without the need of accessory equipment.

The current output option is indicated by an "I" in the model number if the instrument has a grounded current output option, or an "O" if the output is isolated. This letter designation will be immediately followed by a one or two digit number which specifies the maximum output. Thus, O-20 signifies an isolated 4 to 20 mA dc current output. The most common current outputs used are 1 to 5, 4 to 20, and 10 to 50 mA dc.

By special order, isolated voltage outputs from 0–1 mV up to 0–1 V dc can be provided.

Some common current outputs are:

1. 1–5 mA dc suitable for devices with from 0 to 6000 ohms impedance.
2. 4–20 mA dc suitable for devices with from 0 to 1500 ohms impedance.
3. 10–50 mA dc suitable for devices with from 0 to 600 ohms impedance.

### 1.8.3 Optional Feature Packaging

Both the integral-alarm and E-to-I converter options are plug-in printed circuit boards for quick replaceability. When either or both the options are employed in an instrument, a highly-regulated differential power supply (also a plug-in type printed circuit board) is included to supply the positive and negative voltage required by the semiconductor circuitry.



## **Operational Theory**

---

### **2.1 Method of Analysis**

The analysis is specific for oxygen; i.e., the measuring cell will not generate an output current unless oxygen is present in the sample gas. Thus, the instrument has an absolute zero, and no zero gas is required to operate the analyzer.

The measuring cell has the ability to respond accurately to the presence of oxygen irrespective of flowrate. TBE recommends using ambient air as a span gas or, if that is not possible, using a known calibration gas of about 80% of the range of interest value.

The measuring cell (U.S. Pat. #3,429,796) is a solid-state maintenance-free structure that carries a TBE guarantee for performance and usable life. The cell consumes oxygen from the gas surrounding it and generates a proportional microampere current. The low level signal is then amplified by a solid-state operational amplifier, and the resulting DC signal is suitable for driving a high impedance recording device, a temperature compensation circuit for the cell, and an integral 0-100  $\mu\text{A}$  meter. The output signal is linear over the specified ranges of analysis.

Temperature compensation maintains a cell output accuracy of  $\pm 5\%$  from 0  $^{\circ}\text{C}$  to 50  $^{\circ}\text{C}$  (32  $^{\circ}\text{F}$  to 125  $^{\circ}\text{F}$ ) or  $\pm 2\%$  of scale at any constant temperature between the above extremes. Accuracy is limited only by the accuracy of the recording or indicating device used with the analyzer.

### **2.2 Transduction and Temperature Compensation**

The TBE 326 Series Oxygen Analyzers utilize a unique electrochemical transducer whose features include:

- 1) Specificity for oxygen.
- 2) Maintenance-free operation.
- 3) Long calibration interval and life.

- 4) Easy disposal.
- 5) Low cost.

The transducer functions as a fuel cell; in this instance, the fuel is oxygen. Oxygen diffusing into the cell reacts chemically to produce an electrical current that is proportional to the oxygen concentration in the gas phase immediately adjacent to the cell's sensing surface.

Since the cell has a positive temperature coefficient, this variable must be eliminated. The useful life of the cell is limited by the total amount of current produced throughout its life. Taking these two facts into consideration, together with a design goal of providing maximum accuracy, a combination of temperature compensation and temperature control is used. Temperature compensation using thermistor circuits has been used from 30 to 125 °F (0 to 50 °C). This compensation alone will result in an accuracy specification of  $\pm 2\%$  of full scale or 5% of reading. By adding temperature control starting at 25 °C (77 °F) and optimizing the thermistor compensation in the interval between 70 and 125 °F, accuracy has been increased to  $\pm 1\%$ . Even greater accuracy could be achieved by using only temperature control and controlling at 125 °F, but the cell life would be reduced by 50% or more. Therefore, by temperature compensation and temperature control, TBE has achieved reasonable accuracy consistent with long maintenance-free operation.

### 2.3 Integral Cell Protection

An N-channel field effect transistor (FET) is incorporated in the circuitry across the cell to short circuit the cell whenever the power to the instrument is off. The FET switches to a very high resistance instantly when power is supplied to the analyzer, and is essentially no longer part of the circuit.

The FET is necessary because of the characteristics of the cell and the operational amplifier. When in operation, the amplifier input circuit looks like a short of approximately one ohm to the cell. If the power were interrupted without some means of short circuiting the cell, the amplifier would appear as an open circuit to the cell. Since the cell is a current generating device, these two circuit extremes (short circuit-open circuit) would necessitate a prolonged period of equilibration. With the incorporation of the FET in the cell circuit, the cell looks into essentially a short circuit at all times and the instrument responds immediately when power is restored to the circuit.

## 2.3 Cell Types

TBE selects the class of cell used in the analyzer to give the best possible performance for the customer's sample conditions. Several typical cells, their **90% response** times, output **in air**, and typical uses are outlined below:

### 2.3.1 Class A-3 Cell

The Class A-3 cell must be used for any application where the carbon dioxide content of the sample gas is in the region of from 2 to 100% and the sample is monitored continuously.

The A-3 cell output is 0.20 mA, and response is 45 seconds.

### 2.3.2 Class A-5 Cell

Class A-5 cells are used in applications where the carbon dioxide content of the sample gas is continuously within the range of 1-100%, and the sample is monitored intermittently.

The A-5 cell output is 0.19 mA, and response is 45 seconds.

### 2.3.3 Class B-1 Cell

Class B-1 cells are employed in CO<sub>2</sub>-free (between 0-0.1%) applications where fast response is important.

The B-1 cell output is 0.50 mA, and response is 7 seconds.

### 2.3.4 Class B-3 Cell

The B-3 cell is used in applications where a slightly longer response time is acceptable in order to gain a longer cell life.

The B-3 cell output is 0.30 mA, and the response is 13 seconds.

### 2.3.5 Class C-3 Cell

The Class C-3 cell is employed in CO<sub>2</sub>-free (between 0-0.1%) applications where a slower response time can be tolerated in the interest of long cell life.

The C-3 cell output is 0.20 mA, and response is 30 seconds.

### 2.3.6 Warranty Conditions

Customers having warranty claims must return the cell in question to the factory for evaluation. If it is determined that failure is due to faulty material or workmanship the cell will be replaced free of charge. See *Specifications* in the addendum to this manual.

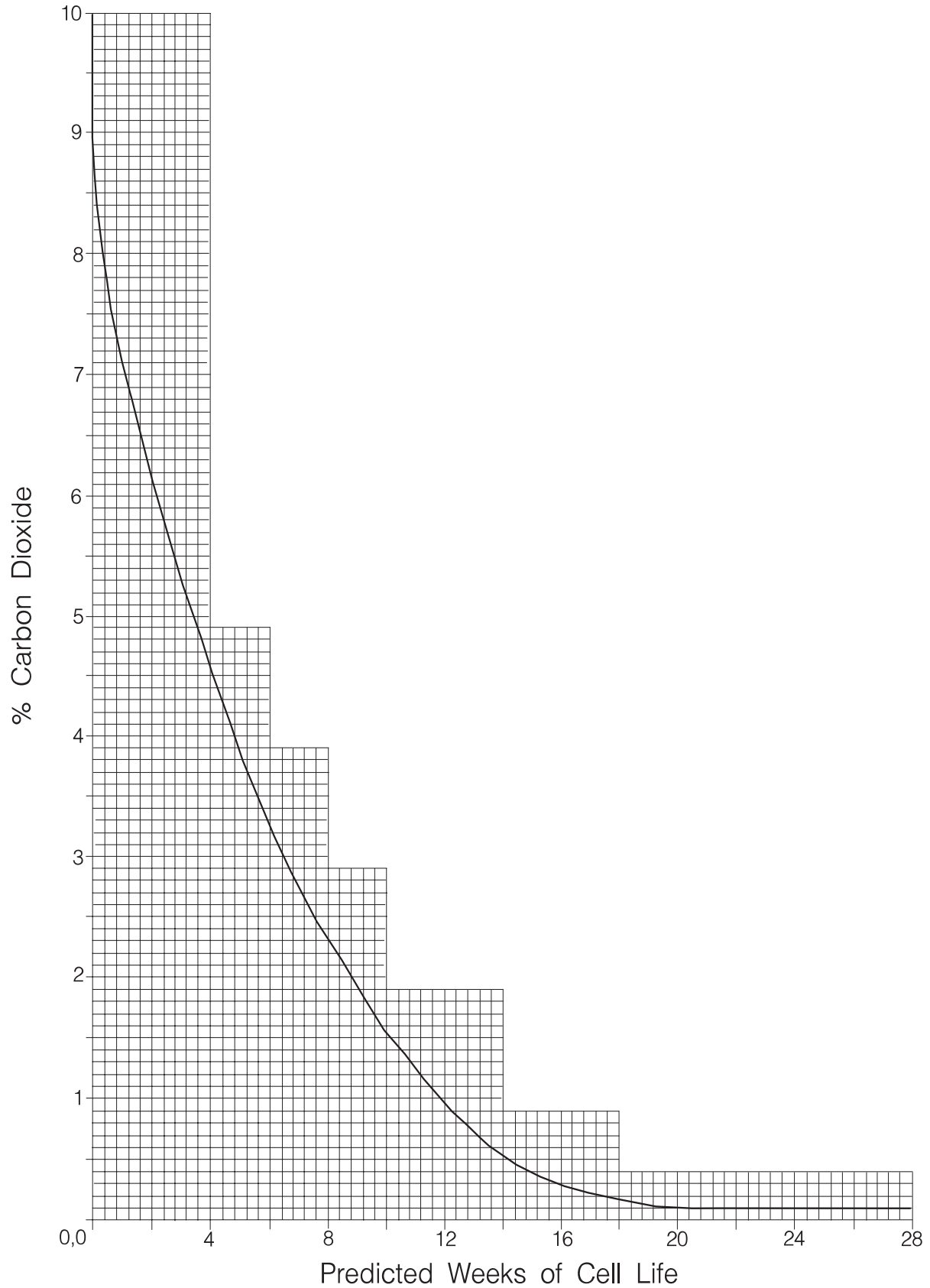

### 2.3.7 CO<sub>2</sub> Effect on C-3 and B-1 Cells

A graph showing the effects of different concentrations of CO<sub>2</sub> on the C-3 and B-1 cells is displayed on the preceding page.

## 2.4 Intrinsic Safety Barriers

Intrinsic safety barriers are used to limit the electrical energy within the controlled circuit to a level too low to cause ignition of a flammable material. The intrinsically safe cell block used in the CENELEC-approved units houses the Micro-Fuel Cell and the temperature compensation thermistor.

The following information has been included in this manual to describe the operation and maintenance considerations involved with the use of intrinsic safety barriers. *Excerpts from the manufacturer's literature are enclosed* to assist in use and replacement of the barriers.

The information provided here is in no way intended to serve as advice of a safety-related nature; its only purpose is to document the components used.

Any and all hazardous conditions to which the analyzer may be exposed are characteristic of the user's environment, and understanding of the conditions and precautions necessary to safe operation are the user's responsibility.

**Bypassing the barriers in any way renders them ineffective.**

**WARNING:** *If the instrument is used in any manner inconsistent with the intent of the intrinsic safety design, the user assumes all risks.*



## Installation

---

**Note:** If you have ordered special options and have obtained a copy of this instruction manual before the instrument is built and fully tested, be aware that special designs and requirements may cause last-minute changes in the sample system, component placement, conduit connections, etc. which will eventually be covered by an addendum in the front of the manual, and by new drawings. If your intention is to install services, accessories, etc., using preliminary information, then you must be aware that changes to your installation may eventually be required. Specially-engineered systems will, of course, be bound by the stipulations of the agreement; nevertheless, unforeseen factors may in some cases necessitate amendments to the agreement by mutual consent.

### 3.1 Location

The analyzer should be installed in an area that is sheltered from the elements. The instrument case of general purpose models is not to be considered water tight (although the model 328R has a sealed, explosion-proof enclosure, and the Analysis Section of the model 327R has a sealed, explosion-proof enclosure). In areas where the ambient temperature is expected to drop below 0 °F, auxiliary heating must be provided.

In analyzers with a separate probe unit, install the probe with a suitable sample system in an area that is protected from the elements and from RFI. The temperature limits are the same as those specified for the sensor, but a constant temperature will increase accuracy. The sample system must provide a flow rate of approximately 1000 ml/minute at a constant temperature. Also, the sample system should include some means of introducing a span gas.

Outline Diagrams showing the location and identification of the gas line and electrical conduit connections, as well as the physical dimensions of the analyzer, are included in the Drawings Section at the rear of the manual.

TAI suggests that the mounting holes be line drilled, using the analyzer itself as a template, after the panel cutout has been made. If the instrument

housing is designed to be wall or bulkhead mounted, allow sufficient room for conduit installation on the wiring access side of the unit.

## 3.2 Electrical Connections

Refer to the Interconnection Diagram and Interconnection Schematic which are included in the Drawings Section at the rear of this manual. For Instruments with separate Control and Analysis Units, each unit may have its own Interconnection Drawings.

### 3.2.1 Power

*Standard Analyzer:* A source of single phase, 50 or 60 hertz, 110 to 120 volt power, capable of delivering 2 amperes of current continuously, is required to operate the standard analyzer.

*327RAC/RBC and the 328RC::* CENELEC models require a source of single-phase, 220 volt, 50/60 hz power capable of delivering 100 watts continuously. The primary power is delivered throughout the analyzer from a single point of entry in the control unit. The appropriate 1/2" conduit access port is identified on the control unit outline diagram. Power service should include an equipment ground wire of the same gauge as the power wiring.

*Special Design Options::* Different requirements may apply to special orders. Consult the Specific Application Information and Drawings sections and any Special Addendums in the manual for complete details.

Connections are made to a terminal strip. In the 326RA and 327RA, the terminal strip is located at the rear of the unit. In the 326RB, 327RB/RBC and 328RC, the terminal is located behind the front door panel. Consult the electrical interconnection and wiring diagrams in the drawings section at the rear of the manual for terminal designations. Observe the Hot, Neutral, and Ground terminals (H, N and G), and install the incoming wiring accordingly. Connect an equipment ground wire to the terminal marked G on the drawing.

For the 327 RA/RB/RAC/RBC and 328R/RC, TAI provides a 4-foot length of cable. If you need a longer cable, use any approved cable that meets the requirements specified on drawing C-39909. Be sure the cable is connected with an approved junction box. The H, N and G wires must be polarized as indicated on the interconnection diagram. If in doubt, check the wiring against the interconnection diagram. Then, check the wiring with a voltmeter to be sure that the H and N wires are not transposed at the barrier strip. (The neutral should read zero voltage when measured to ground.) The

ground wire should be securely attached to a cold water pipe so that personnel are afforded maximum short circuit protection.

As with all other barrier strip connections, the wiring should be terminated in an appropriate lug. Because of the #6 terminal screw and the spacing between barrier dividers, TAI recommends that the gauge of the wire employed not exceed that specified on the interconnection diagram.

### 3.2.2 Output Signal

#### Voltage Output

All models of the 326 series are equipped to provide a 0-1 V dc output signal voltage. Other ranges can be negotiated. Refer to the Specific Application Data and/or Special Addendum to determine the output signal magnitude for specials.

The output signal, regardless of magnitude, is suitable for high impedance devices only (i.e., 10,000 ohms minimum). Optional outputs are required for low impedance devices.

Two conductor, 22 gauge (AWG), shielded cable is recommended for interconnecting the signal and the accessory readout device. Polarize the signal connections as shown on the interconnection diagram (to avoid loss of signal or possible damage to this instrument or other devices), and **connect the shield to the analyzer only**. Do not connect the shield to the accessory instrument, as this will create a ground loop, slowing down the response from the high impedance device.

In the 327RAC/RBC and 328RC, the conduit port most conveniently located with respect to the appropriate barrier strip terminals is indicated on the control unit outline diagram. The conduit access hole is sized for ½" and ¾" conduit.

#### Current Output

Analyzers with the designation I or O appended to the model number are equipped with an E to I converter to provide a DC current output signal, as well as a DC voltage output signal. An O indicates an isolated output, and one or two digits following the O specify the fullscale output in milliamps. An I, followed by one or two digits, indicates a negative-ground output and its fullscale value.

If your instrument is equipped with an isolated current output, be sure to maintain the isolation of both positive and negative conductors from ground.

The standard current output option is 4 to 20 mA dc (O-20 or I-20). Other ranges can be negotiated. Refer to the Specific Application Data and/or Special Addendum to determine the output signal magnitude for specials.

The appropriate terminal strip connections and polarizations are identified on the Schematic and Interconnection Diagram. Always observe the polarity specified on the Schematic and Interconnection Diagrams; otherwise, output indication will be lost, and circuit damage may be caused to the instrument or other devices involved.

Two-conductor shielded cable is recommended for all signal interconnections for the best possible signal protection. For explosion-proof and CENELEC-approved units, consult the control unit outline diagram for the proper conduit access port to use for wiring.

**Important: Make sure that the impedance of the external circuit does not exceed the specified impedance of the current range provided.**

### 3.2.3 Alarm and/or Control Circuitry

Two relay-contact outputs with electronically controlled adjustable setpoints are available for controlling customer-provided equipment, such as an annunciator or shut-down circuitry. They are available with normally-open or normally-closed contacts, Higher-than-setpoint or lower-than-setpoint actuation, and for CENELEC models: 3 amperes maximum, non-inductive contacts.

When this circuitry is installed, the model number includes a -2. The operating characteristics described in the previous paragraph will be documented on the Specific Application Information and/or in an Addendum in the front of the manual.

**CAUTION: Consideration must be given to the energized state of the relays (energized above or below setpoint, and normally-open/normally-closed) to ensure failsafe operation when desired.**

Connections are made to the terminal strips provided, as labeled in the Interconnection Drawings at the rear of the manual.

In models with intrinsic safety barriers, it is vital to know to which side of the setpoint a given relay is energized so that the proper contacts of the SPDT relay switch (normally closed or normally open) can be used in the external circuit. The terms normally open (NO) and normally closed (NC) refer to **the position of the relay switch when its control solenoid is de-energized**. The NO and NC contacts share the C (for common) contact. Any load connected across the NO and C contacts will always see an open circuit (switched off) when the relay is de-energized. Any load connected

across the NC and C contacts will always see a closed circuit (switched on) when the relay is de-energized.

Each set of relay switch contacts (NC-C-NO) is assigned its own barrier strip terminal inside the control unit. Wiring should be no larger than 18 gauge because the external load must be limited to 3 amperes (non-inductive) per relay. All wiring should be installed in the conduit port and be appropriately identified on the control unit outline diagram.

### 3.3 Gas Connections

The sample input, vent, and purge connections are located on the underside of the analyzer case. Both are identified on the outline diagram. TAI suggests that Teflon sealing tape be used as a sealant, rather than pipe dope. Be careful that mated fittings are not cross-threaded before applying force with a wrench. For most applications, the gas connector block in the analyzer is aluminum and can be damaged more easily than the fitting it is mated to.

#### 3.3.1 Pressure Reduction and/or Regulation

Unless span gas is specified, the standard 326R analyzer requires only a pressure-reducing regulator installed at the sample point, and the necessary interconnecting tubing. The regulator should be set between 5 and 50 psig; 10 psig is nominal.

For the 327RAC/RBC and the 328RC, TAI recommends that the sample pressure be reduced **at the sample point** to between 34.5 kPag and 344 kPag (68.9 kPag nominal). If the magnitude of the sample pressure does not exceed 689.5 kPag and is reasonably stable, a simple throttle valve will be satisfactory. If, on the other hand, the pressure is in excess of 689.5 kPag or vacillates over a wide range, a metallic diaphragm regulator should be used. **Do not use a regulator that is equipped with an organic diaphragm under any circumstances.**

For positive-pressure sampling systems, the analyzer may require a pressure reducing regulator installed at the sample point, and the necessary interconnecting tubing. The regulator should be adjusted to provide a nominal pressure of 10 psig.

Other configurations may also be used in specially-designed systems: motorized pumps and aspirator syphons driven by air, water, or a combination of the two, are common methods of drawing sample from processes which do not allow positive pressure sampling. The piping diagram in the drawings section at the rear of the instrument instruction manual is specific

to the exact configuration of the analyzer covered by the manual, and details concerning the sample handling system should be taken from that drawing. The outline drawing provides installation details concerning sample or calibration gas conduit sizes and connecting points.

In systems with a separate sample probe, you must mount the probe, provide the sample and calibration system for the analyzer, and make sure that the probe is protected from the elements and RFI.

### **3.3.2 Recommended Span Gas**

The 326R series has been designed to employ air as the calibration gas. TAI feels that the known oxygen concentration of air (20.9%) is the most reliable standard available. The volume represented by the cell manifold and sample passages has been reduced to a minimum so that the instrument will recover rapidly to the 0-10% range analysis when you follow the proper calibration procedure. (Calibration gas may be specified.)

If the ranges of the analyzer do not encompass the oxygen content of air, span gas will be required to calibrate the instrument. The cylinder span gas will have to be manifolded with the sample gas externally. TAI can furnish gas selector panels, in a variety of configurations, to suit the customer's needs.

Only a span gas with a certified composition should be used, and the cylinder must be equipped with a metallic diaphragm regulator. If the span gas is compressed air (cylinder supplied), a metallic diaphragm-type regulator is not required, since diffusion will not alter its oxygen concentration. When compressed air is supplied by a compressor, a throttle valve should be adequate.

### **3.3.3 Vent Connection**

Wherever possible, vent the analyzer directly to the atmosphere. If venting directly is not possible, the following conditions must be met in vent line installation:

1. The vent line must be constructed so that no appreciable backpressure (from vent line restriction) is experienced by the analyzer. ¼-inch tubing is recommended.
2. The vent line must terminate in an area that experiences no more than normal barometric pressure changes.
3. The vent line must be installed so that water and/or dirt cannot accumulate in it.

### **3.3.4 Sample Conditioning Accessories**

The sample must be free of entrained solids and water. A high humidity sample gas, however, is beneficial, since it will prevent water loss from the cell's electrolyte.



## Operations

---

### 4.1 Preliminary

Before supplying power to the instrument, TBE suggests that the electrical wiring installation and fuses be checked against the interconnection diagram—**particularly if the installation has been made by personnel other than those responsible for startup and operation.** Note that most electrical connections are made directly to terminal blocks on the motherboard.

All accessory hardware, fittings, and gas connections between the analyzer and sample point should be leak tested under pressure prior to startup.

In many instances, proper attention to these two preliminaries will prevent severe damage (accidental wiring transpositions) and ambiguous analysis (diffusion leaks into the sampling system).

### 4.2 Meter Zero

Before applying power to the analyzer (range switch in any position but OFF), check and adjust (if necessary) the mechanical zero of the analyzer (except in models using digital meters). The pointer should indicate zero with the power OFF; if not, adjust the screw on the face of the meter to zero the pointer. This step is important if full advantage of the accuracy of the meter is to be realized, and even more important if remote indicating and/or recording equipment is involved in the system. An offset on the meter will result in a tracking error between the two devices, which becomes significant when the meter is used to calibrate the analyzer.

### 4.3 Model 328RC Meter Adjustment (Electrical)

After turning on the instrument power, allow sufficient time for stabilization. Connect a voltmeter (set to measure at least 1 V dc) between ground (-) and TP1 (+). Turn the span control knob clockwise until the voltmeter reads 1.00 V dc. The analyzer's indicating meter should read full scale; if it does not, then adjust the meter trimmer (P1 on the motherboard) to correct it.

**Cautions: Do not make any adjustments unless necessary.  
Never attempt to make this adjustment with the power ON.**

### 4.4 Measuring Cell Installation

The Micro-Fuel Cell is supplied separately in a controlled atmosphere package, and must be installed prior to startup. It is particularly important with Micro-Fuel Cells that the cell be left in its sealed bag until immediately before the instrument is to be started up and a source of gas containing CO<sub>2</sub> is available. To install the cell, use the following procedure:

- 1) Make sure the range switch is in the OFF position.
- 2) Open the analysis and/or instrument enclosures, so as to expose the analysis section components (sample tubing, measuring cell, etc.)
- 3) Locate the cell holder assembly (plastic cylinder or metal block with electrical cable coming out of one end and sample tubing at the other end). Withdraw the cell probe from holder (use twisting motion); remove cap by unscrewing counterclockwise.
- 4) Open the cell package and remove the shorting clip. Remove the clip from the membrane end first, carefully, making sure not to touch the sensor membrane.

**Caution: Never press on the sensor membrane.**

- 5) Place the Micro-Fuel Cell in the probe with the sensing surface facing out and the printed circuit contacts (concentric gold rings) facing the contacts inside the probe body. Replace cap removed in step 3 (refer to instructions furnished in cell box).
- 6) Insert the cell probe back into the probe holder by pushing and twisting slightly until it seats firmly.

**Note: Try to limit the amount of time the Micro-Fuel Cell is exposed to air.**

#### 4.5 Initial Calibration and Equilibration

Before stable operation can be guaranteed, the Micro-Fuel Cell will require a period of time to adjust itself to its new environment. Monitoring the integral meter, this period of time appears to be about 15 minutes. Actually, there will be a few percentage points of drift for a period of hours after the first 15 minutes of stabilization. This can be demonstrated by recording the output on a circular chart recorder for the first 24 hours of operation.

The instrument can be placed in service before it is completely stabilized. Once it appears to have stabilized (usually about 15 minutes), the slight instability during the first hours of operation is tolerable. The drift during this period can easily be compensated by rezeroing before each reading.

If, on the other hand, reliable analysis, free of instrument distortion, is required from the very onset of operation. TBE recommends a 24 hour run-in period before operational calibration and service.

In either case, employ the following procedure:

- 1) Turn the analyzer range switch to the 0-25% (or highest range) position. This establishes power to all components of the analyzer at minimum sensitivity. If applicable, turn on the accessory readout device.
- 2) Connect analyzer input to a supply of span gas or air.

**Note:** When practical, the instrument may be calibrated by withdrawing the cell probe from the holder and exposing the cell to the surrounding atmosphere.

- 3) Adjust the throttle valve so that an indicated flowrate of 2.0 SCFH (1000 ml/min) registers on the flowmeter. Wait about three to five minutes (allow reading to stabilize) before proceeding to next step.
- 4) Unlock and adjust the span control potentiometer until the meter pointer is in coincidence with the CAL mark (black mark on the red 0-25% scale, at 20.9%) on the meter scale. Relock the span potentiometer.

**Note:** If the instrument does not have a 0-25% range, or if the surrounding atmosphere cannot be used as a span gas, then a span gas will be needed. In that case, adjust the span control until the meter reads the concentration of the span gas.

**Note:** If recorder or remote indicator is used for primary readout, calibrate to 83.9% of full scale on recorder or indicator for maximum accuracy.

- 5) Connect analyzer input to the sample gas and retrim the throttle valve for an indicated flowrate of 2.0 SCFH, or insert probe holder back into its holder.

**Note:** Analyzer accuracy is not affected by variations in sample flowrate. The recommended flowrate of 2.0 SCFH insures maximum speed or response.

- 6) Select the range of analysis that will provide the best possible resolution of the oxygen content of the sample gas.
- 7) Allow sample gas, not calibration air, to flow through the analyzer. For best results, let sample gas flow through the analyzer for 24 hours. This allows the Micro-Fuel Cell to equilibrate.

**Important:** It is particularly vital to the condition of the A-3 cell employed in flue gas (or high CO<sub>2</sub>-content applications) that the cell not be exposed to a CO<sub>2</sub>-free environment for a prolonged period of time.

#### 4.6 Operational Calibration

After the 24-hour equilibration period following the installation of any new cell, or whenever it is desirable to recheck the calibration of the instrument, use the following calibration procedure:

- 1) Place the range selector switch on the 0-25% position.
- 2) Connect the analyzer input to a supply of calibration (span) air and adjust the flowrate to 2.0 SCFH.
- 3) Unlock and adjust the span control until the meter pointer is in precise coincidence with the scale calibration mark and relock the span control.
- 4) Return the instrument to service by restoring sample flow at the proper rate (2.0 SCFH), and selecting the range that provides the best possible resolution of the sample oxygen.

#### 4.7 Calibration of Alarm Equipped Instruments

To prevent generating ambiguous alarms during calibration, simply unlock and rotate the set point dial (or dials) until the limits of travel in the NORMAL (rather than ALARM) direction have been attained. After sample flow has been re-initiated, and the proper scale of analysis selected, the alarm point can be precisely reset by simply re-dialing the set point.

#### 4.8 Calibration of Converter-Equipped Instruments

**Note:** The current output spans 4 to 20 mA corresponding to zero to full scale WITHOUT REGARD TO WHICH RANGE THE ANALYZER IS IN. If the current output is being used to drive a device which must have its input scaled to the particular analysis range, the customer will be required to provide the necessary electrical or mechanical interlocks.

When calibrating, remember the following points:

1. With instruments that are attached to recorders, use the recorder during calibration to improve accuracy. (Most recording equipment is linear to  $\pm 0.25\%$  or better.)
2. Make sure that the sample path flowrate is maintained at 2 SCFH (1000 ml/min).

**Note:** Although the output of the cell is entirely independent of the sample flowrate, the response and recovery is not. To achieve the response and recovery time that is specified on the application information page in the Appendix, the flowrate must be at least 2 SCFH (1000 ml/min).

3. Check to be sure that you have placed the range switch on the position that will give you the best possible resolution of the sample gas after calibration has been completed.

#### 4.9 Special Shutdown for A-3 Cell

**CAUTION:** When the Analyzer is equipped with a Class A-3 cell, it must be protected from prolonged exposure (more than four hours) to CO<sub>2</sub>-free atmospheres (such as air).

The cell can be protected from lack of CO<sub>2</sub> by trapping CO<sub>2</sub>-containing sample (flue gas) by closing the input manifold valves and sealing the vent connection with a valve, water trap, or clamped-off plastic tubing.

#### 4.10 Routine Operational Maintenance

**Sample Flow**

Check the Sample flow daily to make sure that particulate matter is not blocking sample flow.

**4.10.2 Calibration**

Span calibration should be checked every two to four weeks.

## **Maintenance & Troubleshooting**

---

### **5.1 Maintenance**

#### **5.1.1 Routine Maintenance**

Most 326 series analyzers contain no moving parts (although some contain an analog meter movement, solenoid, or relay contacts), and therefore, periodic service is not required. The sample flow check and calibration outlined in Section 4 should be adequate to keep the analyzer functioning throughout the life span of a given Micro-Fuel Cell.

Special designs may require sample systems with filter elements, valves, etc., and those components will require inspection or replacement as needed to keep the instrument in service. A periodic inspection schedule (once per week, once per month, etc.) will be sufficient to determine problems before they become serious.

#### **5.1.2 Special Shut-Down Precaution for Class A-3 Cell**

When the analyzer is equipped with a Class A-3 cell, it must be protected from prolonged exposure (more than 4 hours) to CO<sub>2</sub>-free atmospheres (such as air). This can be accomplished by trapping CO<sub>2</sub>-containing sample (flue gas) by closing the input manifold valves and sealing the vent connection with a valve, water trap or clamped-off plastic tubing.

#### **5.1.3 Cell Replacement**

When the Micro-Fuel Cell nears the end of its useful life, sensitivity will decline very rapidly. The initial response to this phenomenon is to recalibrate the analyzer. If many turns of span control are required, or if the control does not have sufficient range to recalibrate the analyzer, a new Micro-Fuel Cell is required.

Order a replacement cell shortly after the instrument is placed in service, and each time the cell is replaced thereafter.

**CAUTION: DO NOT STOCKPILE SPARE CELLS.** Due to the shelf life of the cells, only one per instrument should be in reserve.

The spare cell should be carefully stored in an area that is not subject to large variations in ambient temperature (24°C nominal), and in such a way as to eliminate any possibility that the cell could be damaged. Do not open the cell package until you are ready to place the cell in the instrument. If the cell package is punctured and air permitted to enter, the cell will immediately begin to react to the presence of oxygen.

After you install the new cell, follow the procedures outlined in the Startup section (3.2 and 3.3) of the manual.

#### 5.1.4 Cell Warranty

If it is determined that failure is due to faulty workmanship or parts, the cell will be replaced at no cost to the customer. If a cell was working satisfactorily, but ceases to function before the warranty period expires, the customer will receive credit, on a pro-rated basis, toward the purchase of a new cell. Customers with warranty claims must return the cell in question to the factory for evaluation.

**WARNING: Any evidence of tampering, or damage through mishandling, will make the cell warranty null and void.**

### 5.2 Troubleshooting

#### 5.2.1 Preliminary Checks

- a. Check Micro-Fuel Cell.
  - (1) Correct cell type for instrument
  - (2) Orientation in socket correct.
  - (3) Shorting clip removed.
  - (4) Diaphragm undamaged.
  
- b. Check printed circuit boards.
  - (1) Installed in proper slots.
  - (2) Inserted fully and making good electrical contact.

- c. Check calibration gasses: zero, span, and sample are appropriate types or formulations for the instrument and cell type.
- d. Instrument has had time to stabilize.
- e. Ambient and sample-gas temperatures are in allowable range for the instrument.

### 5.2.2 Electronics Checks

If the following checks do not give the expected results, problem is probably in the electronics.

- a. Remove Cell: Output should go to zero.
- b. Short cell contacts together: Output should go full scale or higher, or it should go below zero.

### 5.2.3 Gas Checks

- a. Instrument spans OK, but doesn't go to zero with zero gas.
  - (1) There may be a gas leak: Vary the flow rate. If the detected oxygen level varies with flow rate, there is a leak (Leaks can be caused by loose fittings or damaged tubing, or by diffusion through walls of tubing or other parts of the sampling system. A diffusion leak is normally so small that it can be detected only by trace oxygen instruments.)
  - (2) The zero gas may be contaminated. This in turn can be caused by improper regulator attachment procedures.
- b. Instrument zeros OK, but won't span high enough.
  - (1) Exhausted or damaged cell. Replace cell. (Cell damage can be caused by puncturing membrane when removing shorting clip or from storing the cell at too high a temperature.)
  - (2) Incorrect cell for application. Check *Specific Cell Information*.



## Appendix

---

### A.1 Cell Warranty Information

The Micro-fuel Cell carries a warranty that covers its normal life expectancy from date of shipment. Several classes of cell are employed in the various 326-series models. Each class carries its own warranty, and selection of the class cell employed is a function of the customer's application. The most common classes of cell, the guidelines governing their use, and the applicable warranties covering each class are summarized in the following table.

<b>Cell Class</b>	<b>Warranted Life</b>	<b>90% Resp Time</b>	<b>Output in Air</b>
A-3	6 months	45 seconds	0.20 mA
A-5	6 months	45 seconds	0.19 mA
B-1	6 months	7 seconds	0.50 mA
B-3	12 months	13 seconds	0.30 mA
C-3	12 months	30 seconds	0.20 mA

### CO<sub>2</sub> Effect on C-3 and B-1 Cells

A graph showing a plot of a typical curve of the effects of different concentrations of CO<sub>2</sub> on the C-3 and B-1 cells is located in section 2, Operational Theory.

#### To be supplied with final review:

Specifications  
 Calibration data ??  
 Drawings List  
 MSDS

### Recommended Spare Parts List

Qty	Part No	Description	
1*	B-29600	PCB: E to I Converter, Isolated (O Option)	(not 327RAC)
1*	B-14702	PCB: E to I Converter, Neg Gnd (I Option)	(not 327RAC)
1*	A-9309	PCB: Alarm Comparator (-2 Option)	(not 327RAC)
1*	B-43812	PCB: Cell Failure Alarm	(not 327RAC)
1*	A-9306	PCB: Power Supply (used with above options)	(not 327RAC)
1	B-30868	PCB: Temperature Controller	(326RA/RB or 328R only)
1	A-9348	PCB: Oxygen Amplifier	(All Models)
1	B-43812	PCB: Cell Failure Alarm	(326RA/RB, 327RA/RB only)
1	T-176	Thermoswitch	(327RA/RB only)
5	F-9	Fuse: 3AG, 1 Amp	(220 V ac models only)
5	F-10	Fuse: 3AG, 2 Amp	(110 V ac models only)
5	F-527	Fuse: 1/4 Amp	
1	H-28	Heater	(110 V ac models only)
1	H-34	Heater	(220 V ac models only)
1	C-6689	Micro-Fuel Cell: Class **	
1	A-7023	Cell Contact Spring	(All except CENELEC)
1	A-6544	Cell Contact Pin	(All except CENELEC)
1	A-33748	Thermistor Assembly	(326RA/RB, 328R only)
1	T-366	Thermistor	(327RAC only)
1	S-81	Triac	(327RA/RB only)
1	D-186	Dial	
1	M-41	Meter	
1	P-156	Potentiometer: 10k ohms	
1	T-288	Transformer	

\* Optional item. Required only for instruments incorporating the option.

Any of these also require an A-9306 PCB.

EXCEPTIONS: All standard in 328RC. None available in 327RAC.

\*\* Per Sales Order. See Specific Application Data in front of Table of Contents.

A MINIMUM CHARGE OF \$15.00 IS APPLIED TO SPARE PARTS ORDERS.

**IMPORTANT:** Orders for replacement parts should include the part number (if available) and the model and serial number of the system for which the parts are intended.

SEND ORDERS TO :

Teledyne Brown Engineering  
Analytical Instruments  
16830 Chestnut Street  
City of Industry, California 91749-1580

Telephone (818) 961-9221  
TWX: (910) 584-1887 TDYANYL COID  
Or your local representative.

### REFERENCE DRAWINGS

#### Model 326RA/RB

#### Model 327RA/RB

#### Model 327RAC/RBC

#### MODEL 327RAC

B-39931	OUTLINE DIAGRAM - PROBE ASSEMBLY
C-39936	OUTLINE DIAGRAM - SAFETY BARRIER ENCLOSURE
B-39932	OUTLINE DIAGRAM - CONTROL UNIT
A-8317	PIPING DIAGRAM - SUGGESTED
C-31945	SCHEMATIC - MOTHER PC BOARD
C-39899	SCHEMATIC - INTERCONNECTION
B-33779	SCHEMATIC - OXYGEN AMPLIFIER
C-39909	INTERCONNECTION DIAGRAM
C-39898	WIRING DIAGRAM

#### MODEL 328RC

D-43287	OUTLINE DIAGRAM - HOUSING
B-39931	OUTLINE DIAGRAM - PROBE
C-43264	WIRING & INTERCONNECTION DIAGRAM
C-31945	SCHEMATIC - MOTHER PC BOARD
C-43265	SCHEMATIC - INTERCONNECTION
B-33779	SCHEMATIC - OXYGEN AMPLIFIER
B-33129	SCHEMATIC - POWER SUPPLY
B-33128	SCHEMATIC - ALARM
B-29602	SCHEMATIC - E/I CONVERTER

Specs page  
Calibration data  
drawing list  
MSDS



NOTES: UNLESS OTHERWISE SPECIFIED.

REVISIONS				
REV	DESCRIPTION	DATE	APP.	REV. BY
8	REDRAW	12-21-92	JAG	--
9	ADD CONNECTION TO R4	10-25-93	DS	M.V.

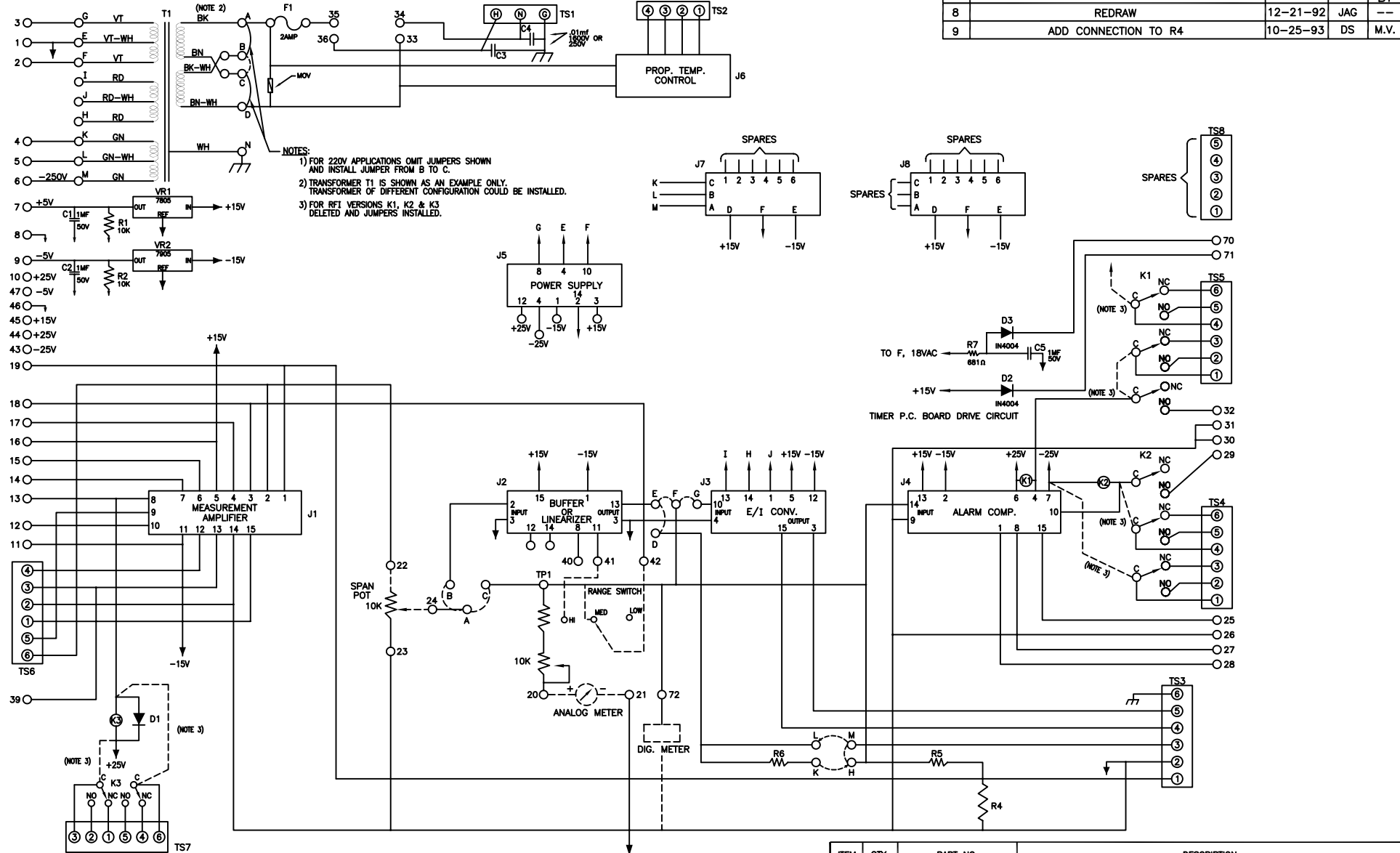

- NOTES:
- 1) FOR 220V APPLICATIONS OMIT JUMPERS SHOWN AND INSTALL JUMPER FROM B TO C.
  - 2) TRANSFORMER T1 IS SHOWN AS AN EXAMPLE ONLY. TRANSFORMER OF DIFFERENT CONFIGURATION COULD BE INSTALLED.
  - 3) FOR RFI VERSIONS K1, K2 & K3 DELETED AND JUMPERS INSTALLED.

ITEM	QTY	PART NO.	DESCRIPTION
BILL OF MATERIAL			
DO NOT SCALE DWG		THIS DRAWING IS THE PROPERTY OF TELEDYNE ANALYTICAL INSTRUMENTS AND CONTAINS CONFIDENTIAL INFORMATION. IT IS NOT TO BE COPIED, REPRODUCED OR USED WITHOUT WRITTEN PERMISSION.	
TOLERANCE UNLESS OTHERWISE SPECIFIED: ANGULAR ±1/2"		 <b>TELEDYNE ELECTRONIC TECHNOLOGIES</b> Analytical Instruments An Alcatel Telecommunications Company CITY OF INDUSTRY, CALIFORNIA 91748	
LINEAR .XX = ±.1			
.XXX = ±.005			
S/	SIGNATURES	DATE	TITLE
I/	DRFT: <i>Marilpa</i>	3/21/96	<b>UNIVERSAL MOTHER P.C. BOARD SCHEMATIC DIAGRAM</b>
N/	CHK: <i>Vig</i>	3/21/96	
P/	APPR:		
O/	ENGR:		
F/	S.O.		
REFERENCE	CAD ID C31945-9	MATL.	DWG NO. C-31945

S/	I/	N/	P/	O/	F/
	DRFT: <i>Marilpa</i>	CHK: <i>Vig</i>	APPR:	ENGR:	S.O.
	DATE: 3/21/96	DATE: 3/21/96			

SCALE	---
SIM	
SHEET	1 OF 1
REV	9

NOTES: UNLESS OTHERWISE SPECIFIED.

- ① ASSEMBLE ITEM 3, 32 & 39-44, 58, 59 AS SHOWN ON DDW.# C-33777 ALSO INSTALL JUMPERS AS SHOWN.
- ② FOR LOCATION AND INSTALLATION OF ITEMS 45 THRU 50, SEE DRAWING #C-34879.
- 3. OUTLINE: C34879
- 4. WIRING DIAGRAM: C35783
- ⑤ REQUIRED ONLY WHEN IN SYSTEM WITH PUMP.

REVISIONS				
REV	DESCRIPTION	DATE	APP.	REV. BY
18	INC. ECO# 98-0362	2/24/99	A.M.	VF
19	INC. ECO# 99-0274	6-30-99	R.F.	M.V.

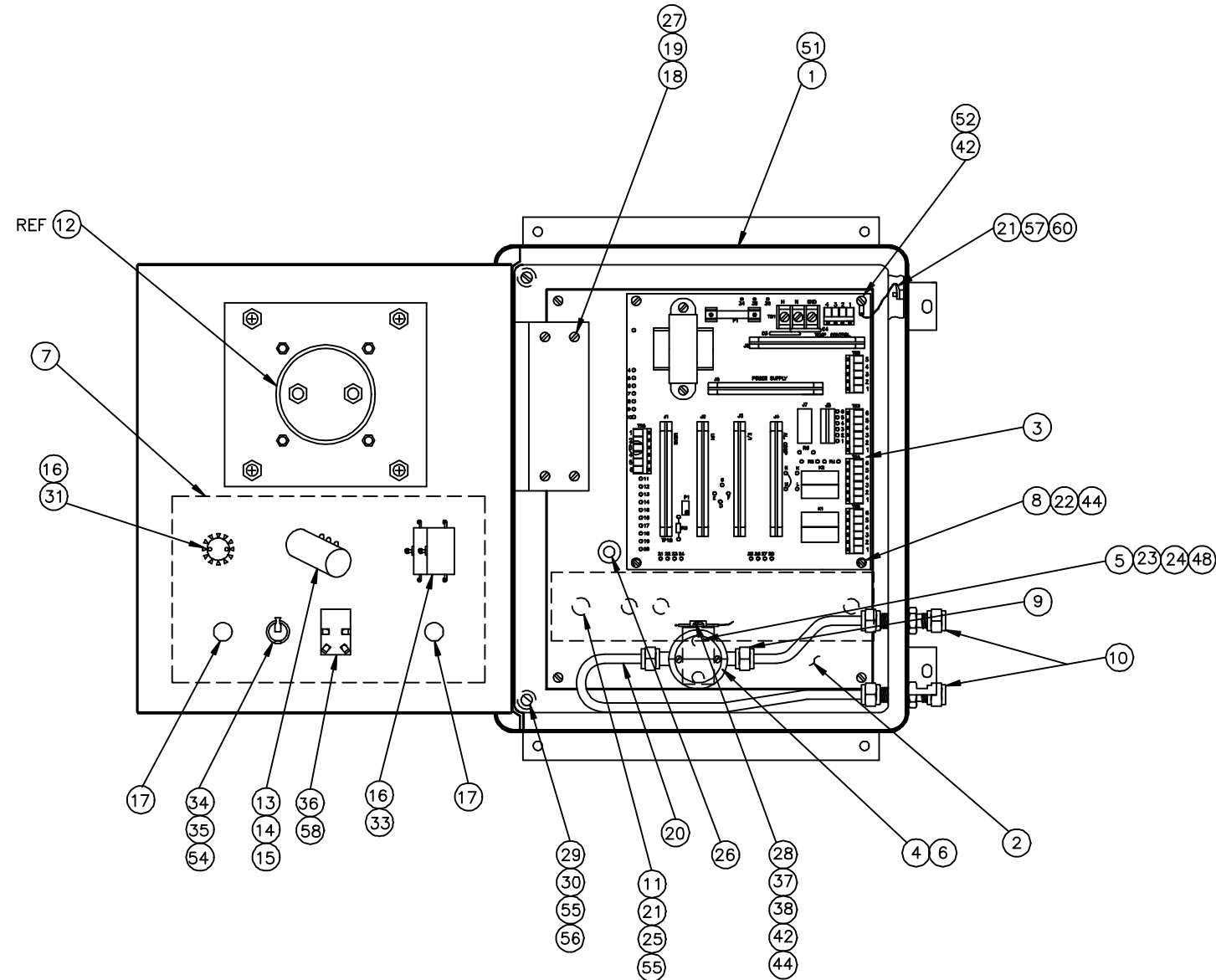

REF	QTY	PART NO.	DESCRIPTION	
61	REF	D34204-RS	ROUTE SHEET	
60	1	-----	SHAKE PROOF NUT, No.10, HEX	
59	1	A-9306	PCB, POWER SUPPLY	
58	1	B-29600	PCB, ISOLATED E TO I CONVERTER	
57	1	-----	GROUND LUG #10	
56	4	-----	NUT, #10 CAP	
55	6	-----	LOCK WASHER #10	
54	2	A-8582-2	PLUG	
53	1	N 104	LOGO (NOT SHOWN)	
52	1	-----	GROUND LUG #6	
51	2	C 1020	CLAMP SCREW (HOFFMAN)	
②	50	1	B-41370	CONNECTOR TUBE
②	49	2	-----	NUT HEX, 8-32
②	48	4	-----	LOCK WASHER #8
②	47	2	-----	SCREW, 8-32 X 5/8" LG BIND HD
②	46	A/R	-----	TUBING, 1/4 OD X .030 WALL SS
②	45	1	B-11022	GAS SELECTOR PANEL ASSY (NOT SHOWN)
①	44	7	-----	LOCK WASHER, NO. 6
①	43	2	-----	NUT, 6-32
①	42	7	-----	SCREW, 6-32 X 1/4 LG, BIND HD
①	41	1	T 288	TRANSFORMER
①	40	1	B-30868	TEMP. CONT. PC BD ASSY
①	39	1	A-9348	AMP PC BD ASSY
①	38	1	A-34812	THERMISTOR MTG BRKT DETAIL
①	37	1	-----	METAL CLAMP H.H. SMITH 1471
⑤	36	A/R	S 176	SWITCH
⑤	35	A/R	F 77	FUSE, 6 1/4 AMP, 3 AG, SLO-BLO
⑤	34	A/R	F 13	FUSE HOLDER
①	33	1	S 51	SWITCH
①	32	1	F 10	FUSE, 2 AMP
①	31	1	S 412	SWITCH
①	30	4	-----	NUT, #10 RADIO
①	29	4	S 486	SPACER, #10-32 (MALE ADAPTER)
①	28	1	A-33748	THERMISTOR SUB-ASSEMBLY
⑤	27	A/R	-----	SCREW NO. -32 X LONG, BIND HEAD
①	26	1	G 4	GROMMET HH 2172
①	25	2	-----	FLAT WASHER FOR NO. 10 SCREW
①	24	2	-----	SET SCREW NO. 8-32 X 3/4" LG
①	23	2	-----	SCREW NO. 8-32 X 3/8 LG, FLAT HD
①	22	8	-----	SCREW NO. 6-32 X 3/8 LG, BIND HD
①	21	3	-----	SCREW NO. 10-32 X 3/8 LG, BIND HD
①	20	A/R	-----	TUBING, 1/4" OD POLYFLOW
⑤	19	A/R	T 75	TERMINAL STRIP 9-141
⑤	18	A/R	T 126	MARKER STRIP MS-9-141
①	17	2	A-8582-3	PLUG
①	16	2	K 6	KNOB
①	15	1	K 5	LOCK KNOB
①	14	1	K 3	KNOB
①	13	1	P 156	POT 10K
①	12	1	M 70	METER
①	11	1	H 2	HEATER, VULCAN 1208, 50 WATTS
①	10	2	U 2	UNION BULKHEAD 1/4T SS
①	9	2	C 273	CONNECTOR 1/4T X 1/8 MNPT SY
①	8	4	S 525	SPACER, HEX, M/F THD 1/4 HEX, 1/2 LG 6-32 UNC-2B
①	7	1	B-34205	TAG DETAIL
①	6	1	B-9871	PROBE ASSEMBLY
①	5	2	C-2171-I	SPACER 1" LG, DETAIL "I"
①	4	1	A-27652	RECEPTACLE SUB-ASSEMBLY
①	3	1	C-31943	MOTHER PC BOARD ASSEMBLY
①	2	1	C-34206	BACK PANEL DRILLING DETAIL
①	1	1	C-34207	BOX DRILLING DETAIL

ITEM	QTY	PART NO.	DESCRIPTION
BILL OF MATERIAL			
DO NOT SCALE DWG			
TOLERANCE UNLESS OTHERWISE SPECIFIED: ANGULAR ±1/2°			
LINEAR .XX = ±.02			
.XXX = ±.010			
THIS DRAWING IS THE PROPERTY OF TELEDYNE ANALYTICAL INSTRUMENTS AND CONTAINS CONFIDENTIAL INFORMATION. IT IS NOT TO BE COPIED, REPRODUCED OR USED WITHOUT WRITTEN PERMISSION.			
TELEDYNE ANALYTICAL INSTRUMENTS An Analytical Instruments Company CITY OF INDUSTRY, CALIFORNIA 91748			
SIGNATURES		DATE	TITLE
N/	DRFT: F. LOZANO	12/14/83	
I/	CHK:		
O/	APPR:		
P/	ENGR:		
F/	S.O.:		
REFERENCE	CAD ID D3420419		
SCALE NTS			SHEET 1 OF 1
TITLE FINAL ASSEMBLY OXYGEN ANALYZER BASIC MODEL 326RB			REV 19
MATERIAL AS LISTED			DWG NO. D-34204

REV. NO.	DATE	REVISION / ECO NUMBER	APP
1	10-11-83		ML
2	11-20-83	REV'D RANGE SW	AK
3	02-20-85	REVISION	AK
4	4-20-85	ADDED NOTES	AK
5	9-16-86	ECO # 86-0142	AK
6	8-5-87	ECO # 87-0129	AK
7	10-14-87	R11 (POT) WAS R1; ADDED CONN. CALL OUT J1-15	g.a.r.

ITEMS INSIDE DOTTED LINE USED ONLY WHEN NO OPTIONS ARE CALLED FOR.

UNITS WITH OPTIONS USE X CONV ALARMS USE SEPARATE POWER SUPPLY REF: DWG. B33129

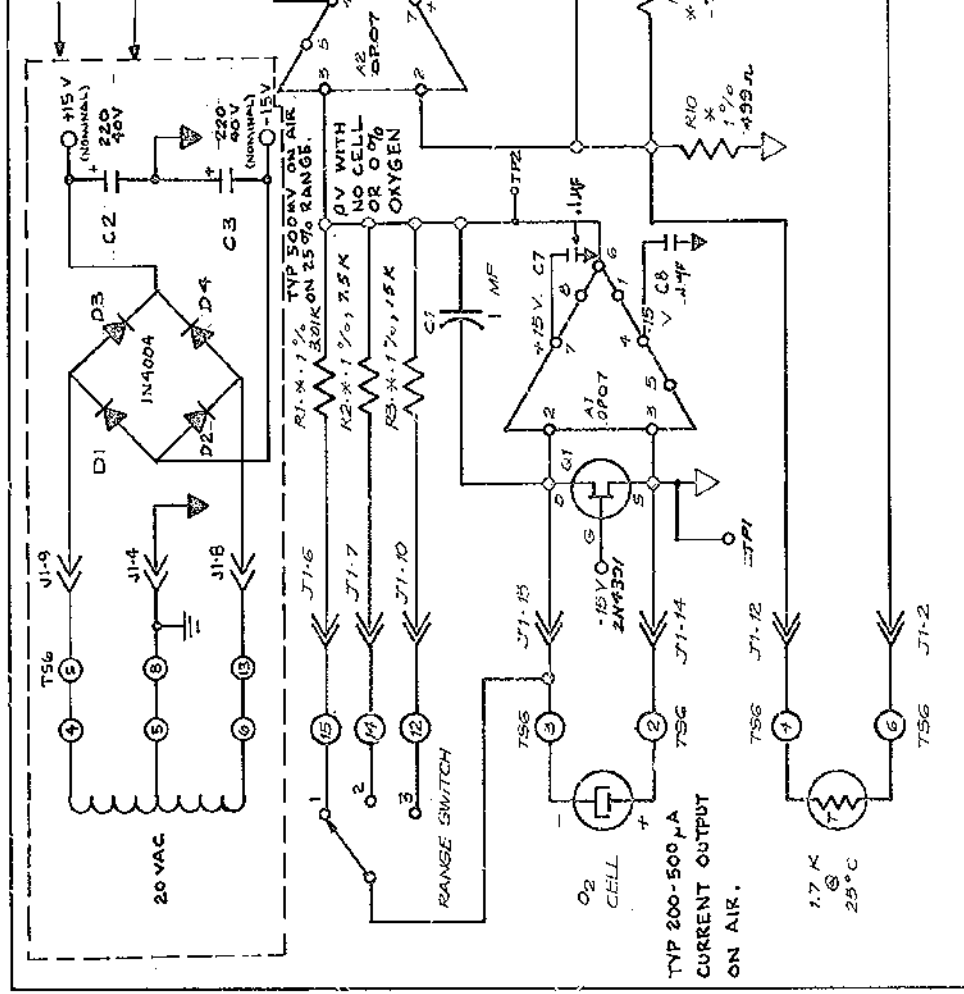

ITEM	PART NO.	REQ.	DESCRIPTION
TOLERANCE UNLESS OTHERWISE SPECIFIED			
FRAC.	1/16"		
DEC.	1.008"		
ANGULAR	± 3/2"		
TELEDYNE ANALYTICAL INSTRUMENTS CITY OF INDUSTRY, CALIFORNIA 91748			
MDL 326P, 327P, 328R OXYGEN ANALYZER AMPLIFIER SCHEMATIC			
7.03 A 919 V			
W/C 33610			
9.0125645			

SEE SCHEMATIC C-33778

NOTES:

- RESISTORS ARE 1/8 W, ± 1% METAL FILM.
- BOARD MOUNTED TRIM POTS ARE FACTORY SET, DO NOT ADJUST.
- RESISTORS MARKED X ARE SELECTED PER APPLICATION:  
R1 = \_\_\_\_\_ KΩ  
R2 = \_\_\_\_\_ KΩ  
R3 = \_\_\_\_\_ KΩ

Q1 IS USED TO SHORT CELL IF POWER IS SWITCHED OFF, OTHERWISE IT HAS NO EFFECT.

SCALE	DATE	SCALE	DATE
MATL	10-23-83		
DRAWING			
DR. NAME		ENGR.	
B-33779			