

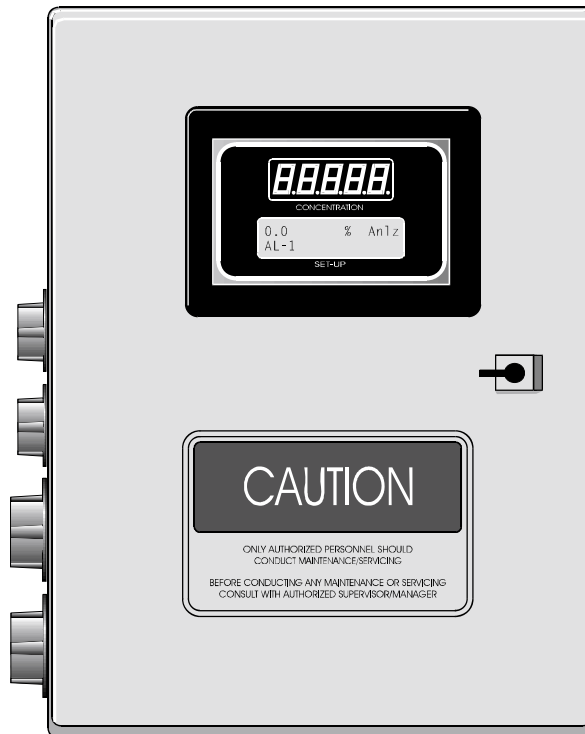

OPERATING INSTRUCTIONS

Model 3010TB

Trace Oxygen Analyzer

Bulkhead Mount Control Unit, PN **D-66190A***
NEC Type Analysis Unit, PN **D-65478***



	DANGER	
<p>HIGHLY TOXIC AND OR FLAMMABLE LIQUIDS OR GASES MAY BE PRESENT IN THIS MONITORING SYSTEM.</p> <p>PERSONAL PROTECTIVE EQUIPMENT MAY BE REQUIRED WHEN SERVICING THIS SYSTEM.</p> <p>HAZARDOUS VOLTAGES EXIST ON CERTAIN COMPONENTS INTERNALLY WHICH MAY PERSIST FOR A TIME EVEN AFTER THE POWER IS TURNED OFF AND DISCONNECTED.</p> <p>ONLY AUTHORIZED PERSONNEL SHOULD CONDUCT MAINTENANCE AND/OR SERVICING. BEFORE CONDUCTING ANY MAINTENANCE OR SERVICING CONSULT WITH AUTHORIZED SUPERVISOR/MANAGER.</p>		

P/N M62927
11/24/04
ECO: #03-0126

Copyright © 1999 Teledyne Analytical Instruments

All Rights Reserved. No part of this manual may be reproduced, transmitted, transcribed, stored in a retrieval system, or translated into any other language or computer language in whole or in part, in any form or by any means, whether it be electronic, mechanical, magnetic, optical, manual, or otherwise, without the prior written consent of Teledyne Analytical Instruments, 16830 Chestnut Street, City of Industry, CA 91749-1580.

Warranty

This equipment is sold subject to the mutual agreement that it is warranted by us free from defects of material and of construction, and that our liability shall be limited to replacing or repairing at our factory (without charge, except for transportation), or at customer plant at our option, any material or construction in which defects become apparent within one year from the date of shipment, except in cases where quotations or acknowledgements provide for a shorter period. Components manufactured by others bear the warranty of their manufacturer. This warranty does not cover defects caused by wear, accident, misuse, neglect or repairs other than those performed by Teledyne or an authorized service center. We assume no liability for direct or indirect damages of any kind and the purchaser by the acceptance of the equipment will assume all liability for any damage which may result from its use or misuse.

We reserve the right to employ any suitable material in the manufacture of our apparatus, and to make any alterations in the dimensions, shape or weight of any parts, in so far as such alterations do not adversely affect our warranty.

Important Notice

This instrument provides measurement readings to its user, and serves as a tool by which valuable data can be gathered. The information provided by the instrument may assist the user in eliminating potential hazards caused by his process; however, it is essential that all personnel involved in the use of the instrument or its interface, with the process being measured, be properly trained in the process itself, as well as all instrumentation related to it.

The safety of personnel is ultimately the responsibility of those who control process conditions. While this instrument may be able to provide early warning of imminent danger, it has no control over process conditions, and it can be misused. In particular, any alarm or control systems installed must be tested and understood, both as to how they operate and as to how they can be defeated. Any safeguards required such as locks, labels, or redundancy, must be provided by the user or specifically requested of Teledyne at the time the order is placed.

Therefore, the purchaser must be aware of the hazardous process conditions. The purchaser is responsible for the training of personnel, for providing hazard warning methods and instrumentation per the appropriate standards, and for ensuring that hazard warning devices and instrumentation are maintained and operated properly.

Analytical Instruments, the manufacturer of this instrument, cannot accept responsibility for conditions beyond its knowledge and control. No statement expressed or implied by this document or any information disseminated by the manufacturer or its agents, is to be construed as a warranty of adequate safety control under the user's process conditions.

Table of Contents

Specific Model Information iv

Preface v

Part I: Control Unit, Model TB Part I: 1-1

Part II: Analysis Unit, Model T Part II: 1-1

Appendix A-1

Specific Model Information

The instrument for which this manual was supplied may incorporate one or more options not supplied in the standard instrument. Commonly available options are listed below, with check boxes. Any that are incorporated in the instrument for which this manual was supplied are indicated by a check mark in the box.

Instrument Serial Number: _____

The instrument with the above serial number has the following Options:

- o **3010TB-C** Three gas inputs, for sample, zero and span gases, with three solenoid-actuated gas-flow control valves built in. Valves are automatically synchronized to the analyzer's electronic control sequences.
- o **3010TB-F** Built-in flame arresters for Groups C and D service.
- o **3010TB-G** Built-in flame arresters for Groups C and D service, plus gas-control valves as in -C option, above.
- o **3010TB-H** Built-in flame arresters for Group B (hydrogen) service.
- o **3010TB-I** Built-in flame arresters for Group B (hydrogen) service, plus gas-control valves as in -C option, above.
- o **Cell Class*** _____ (L-2C standard).
Enter Class Designation

* See *Part II, Chapter 2* and/or any addendum that may be attached to this manual for cell specifications.

Preface

Overview

The Analytical Instruments Model 3010TB Trace Oxygen Analyzer is a versatile microprocessor-based instrument for detecting parts-per-million (ppm) levels of oxygen in a variety of background gases. It is a “split architecture” instrument. This means that a general purpose Control Unit, designed for nonhazardous areas only, remotely controls a specially designed Analysis Unit, or remote probe, that can operate in a hazardous area.

Part I of this manual covers the Model 3010TB General Purpose NEMA 4 Bulkhead mount Control Unit only. This Control Unit is for outdoor/indoor use in a nonhazardous environment. The Analysis Units (or Remote Probes) it controls, can be designed for a variety of hazardous environments. Part II of this manual covers the 3010T Analysis Unit.

Typical Applications

A few typical applications of the Model 3010TB are:

- Monitoring inert gas blanketing
- Air separation and liquefaction
- Chemical reaction monitoring
- Semiconductor manufacturing
- Petrochemical process control
- Quality assurance
- Gas analysis certification.

Model and Part Number Designations

The part numbers are the most specific identification. When using this manual for operation, maintenance, or ordering parts, check the part numbers on your Instruments to be sure of a match. Where an underscore (_) appears in a model number, the unit has more than one application. For example, 3010T_C means that the same unit is part of the 3010TAC and the 3010TBC series and consists of two sections; Control Unit and Remote Analysis or Sensor Probe.

- 3010TA:** NEC Type Trace Oxygen Analyzer with flush mount Control Unit, **PN D-64596A** and a 3010T Explosion Proof Analysis Unit, **PN D-65478**.
- 3010PA:** NEC Type Percent Oxygen Analyzer with flush mount Control Unit, **PN D-64596B** or **C** and 3010P Explosion Proof Analysis Unit, **PN D-65479**.
- 3010TB:** NEC type Trace Oxygen Analyzer with bulkhead mount Control Unit, **PN D-66190A**, and a 3010T Explosion Proof Analysis Unit, **PN D-65478**.
- 3010PB:** NEC type Percent Oxygen Analyzer with bulkhead mount Control Unit, **PN D-66190 B** or **C**, and a 3010T Explosion Proof Analysis Unit, **PN D-65479**.
- 3010TAC:** CENELEC type Trace Oxygen Analyzer with flush mount Control Unit, **PN D-66192A**, and a 3010T_C Remote Sensor, **PN D-66193**.
- 3010PAC:** CENELEC type Percent Oxygen Analyzer with flush mount Control Unit, **PN D-66192 B** or **C**, and a 3010P_C Remote Sensor, **PN D-66191**.
- 3010TBC:** CENELEC type Trace Oxygen Analyzer with bulkhead mount Control Unit, **PN D-66194A**, and a 3010T_C Remote Sensor, **PN D-66193**.
- 3010PBC:** CENELEC type Percent Oxygen Analyzer with bulkhead mount Control Unit, **PN D-66194 Bor C**, and a 3010P_C Remote Sensor, **PN D-66191**.
- Options:** See *Specific Model Information* sheet, on page *iv* for details.

Main Features of the Analyzer

The Model 3010TB series Oxygen Analyzers are sophisticated yet simple to use. The main features of these analyzers include:

- A 2-line alphanumeric display screen, driven by microprocessor electronics, that continuously prompts and informs the operator.
- High resolution, accurate readings of oxygen content: from low ppm levels through 25%. Large, bright, meter readout.
- Stainless steel cell block is standard equipment.
- Advance design Micro-Fuel Cell sensor, Specially designed model for trace analysis, has a one year warranty and an expected lifetime of two years.
- Versatile analysis over a wide range of applications.
- Microprocessor based electronics: 8-bit CMOS microprocessor with 32 kB RAM and 128 kB ROM.
- Three user definable output ranges allow best match to users process and equipment: 0-10 ppm through 0-250,000 ppm for trace analysis.
- Air-calibration range for convenient spanning at 20.9 %.
- Auto Ranging allows analyzer to automatically select the proper preset range for a given measurement. Manual override allows the user to lock onto a specific range of interest.
- Two adjustable concentration alarms and a system failure alarm.
- Self-diagnostic testing, at startup and on demand, with continuous power-supply monitoring.
- Two way RFI protection.
- RS-232 serial digital port for use with a computer or other digital communications device.
- Analog outputs for Concentration and Analysis Range: 0–1 V dc standard. Isolated 4–20 mA dc standard.
- Compact and versatile design: flush-panel, rack-mountable, or bulkhead mounted Control Units available.

OPERATING INSTRUCTIONS

Model 3010TB

Oxygen Analyzer

Part I: Control Unit

NEMA 4 Bulkhead Mount

Part Numbers: D-**66190A**

Table of Contents

1 Introduction

1.1 Overview 1-1
1.2 Control Unit Inner Control Panel 1-1
1.3 Recognizing Difference Between LCD & VFD 1-3
1.4 Control Unit Interface Panel 1-4

2 Operational Theory

2.1 Introduction 2-1
2.2 Electronics and Signal Processing 2-1

3 Installation

3.1 Unpacking the Control Unit 3-1
3.2 Mounting the Control Unit 3-1
3.3 Electrical Connections 3-3
3.4 Testing the System 3-12

4 Operation

4.1 Introduction 4-1
4.2 Using the Data Entry and Function Buttons 4-2
4.3 The *System* Function 4-3
 4.3.1 Tracking the O₂ Readings during Calibration 4-4
 4.3.2 Setting up an Auto-Cal 4-5
 4.3.3 Password Protection 4-5
 4.3.3.1 Entering the Password 4-6
 4.3.3.2 Installing or Changing the Password 4-7
 4.3.4 Logout 4-8
 4.3.5 System Self-Diagnostic Test 4-9
 4.3.6 Version Screen 4-10
 4.3.7 Showing Negative Oxygen Readings 4-10
4.4 The *Zero* and *Span* Functions 4-10
 4.4.1 Zero Cal 4-11

4.4.1.1	Auto Mode Zeroing	4-11
4.4.1.2	Manual Mode Zeroing	4-12
4.4.1.3	Cell Failure	4-13
4.4.2	Span Cal	4-14
4.4.2.1	Auto Mode Spanning	4-14
4.4.2.2	Manual Mode Spanning	4-16
4.4.3	Span Failure	4-16
4.5	The <i>Alarms</i> Function	4-15
4.6	The <i>Range</i> Function	4-18
4.6.1	Setting the Analog Output Ranges	4-19
4.6.2	Fixed Range Analysis	4-20
4.7	The <i>Analyze</i> Function	4-20
4.8	Signal Output	4-21

5 Maintenance

5.1	Fuse Replacement	5-1
5.2	System Self Diagnostic Test	5-2
5.3	Major Internal Components	5-3
5.4	Cleaning	5-4

A Appendix

	Model 3010TB Specifications	A-3
--	-----------------------------------	-----

Operational Theory

2.1 Introduction

The Model 3010TB Oxygen Analyzer Control Unit uses an 80C31 microcontroller with 32 kB of RAM and 128 kB of ROM to control all signal processing, input/output, and display functions for the Model 3010TB analyzer. (The sample system and Micro-Fuel Cell sensor are covered in Part II, *Analysis Unit*, in this manual.) System power is supplied from a universal power supply module designed to be compatible with any international power source.

2.2 Electronics and Signal Processing

All of the Analyzer electronics are located on Printed Circuit Board (PCB) assemblies inside the Control Unit chassis. The PCB locations are illustrated in section 5, *Maintenance*.

Refer to Figure 2-1, *Block Diagram of the 3010TB CU Electronics*:

In the presence of oxygen, the sensor (in the Analysis Unit) generates a current. A current to voltage amplifier (in the Control Unit) converts this current to a voltage.

The second stage amplifier amplifies the voltage. It also uses a signal from the thermistor (which is physically located in the Analysis Unit cell block) to provide temperature compensation for the sensor signal. The thermistor is a temperature dependent resistance that changes the gain of the amplifier in proportion to the temperature changes in the block. This thermistor signal compensates for the change in the cell output due to the temperature changes. The result is a signal that is temperature independent. The output from the second stage amplifier is sent to an 18-bit analog to digital converter controlled by the microprocessor.

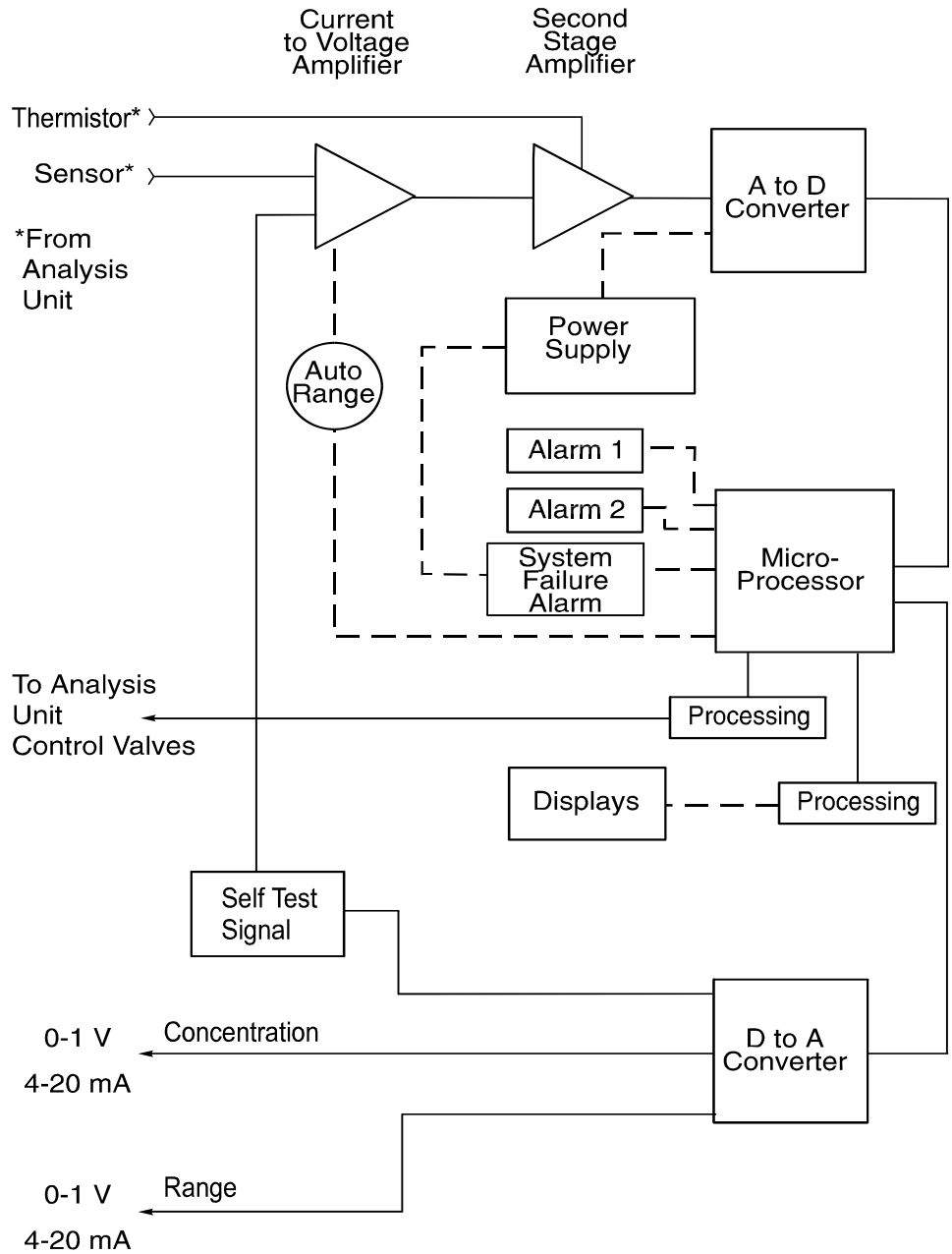

Figure 2-1: Block Diagram of the 3010TB CU Electronics

The digital concentration signal—along with input from the control panel—is processed by the microprocessor, and appropriate control signals are directed to the display, alarms and communications port as well as to the gas control valves in the Analysis Unit.

The same digital information is also sent to a 12 bit digital to analog converter that produces the 4-20 mA dc and the 0-1 V dc analog concentration signal outputs, and the analog range ID outputs.

The microprocessor monitors the power supply, and activates the system failure alarm if a malfunction is detected.

Installation

Installation of Model 3010 Analyzers includes:

1. Unpacking, mounting, and interconnecting the Control Unit and the Analysis Unit
2. Making gas connections to the system
3. Making electrical connections to the system
4. Testing the system.

This chapter covers installation of the Control Unit. (Installation of the Analysis Unit is covered in Part II of this manual.)

3.1 Unpacking the Control Unit

The analyzer is shipped with all the materials you need to install and prepare the system for operation. Carefully unpack the Control Unit and inspect it for damage. Immediately report any damage to the shipping agent.

3.2 Mounting the Control Unit

The Model 3010TB Control Unit is for indoor/outdoor use in a general purpose area. This Unit is NOT for any type of hazardous environments.

The standard model is designed for indoor/outdoor mounting. Figure 3-1 is an illustration of a Model 3010TB standard Control Unit front panel and mounting brackets located-two at the top and two at the bottom of the units frame. Drawing number D-64808, at the back of this manual, contains an outline mounting diagram.

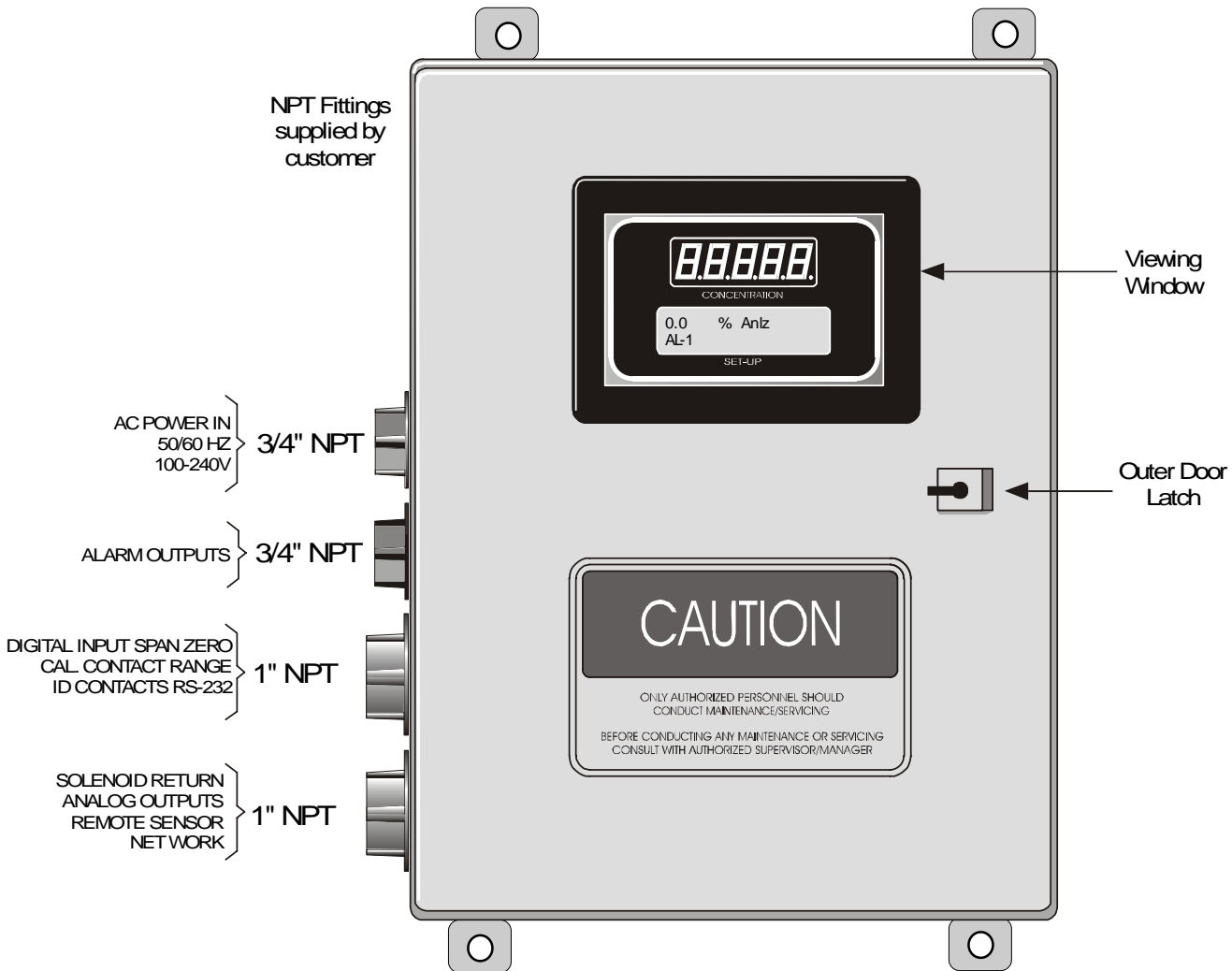

Figure 3-1: Front Panel of the Model 3010 Control Unit

All operator controls are mounted on the inner control panel, which is hinged on the left edge and doubles as a door to provide access to the internal components of the instrument. The door will swing open when the button of the latch is pressed all the way in with a narrow gauge tool (less than 0.18 inch wide), such as a small hex wrench or screwdriver. Allow

clearance for the door to open in a 90-degree arc of radius 11.75 inches. See Figure 3-2.

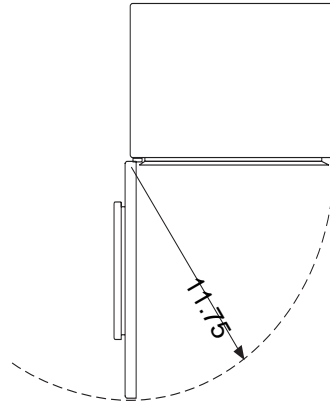

Figure 3-2: Required Front Door Clearance

3.3 Electrical Connections

Figure 3-3 shows the Control Unit interface panel. Connections for power, communications, and both digital and analog signal outputs are described in the following paragraphs. Wire size and maximum length data appear in the Drawings at the back of this manual.

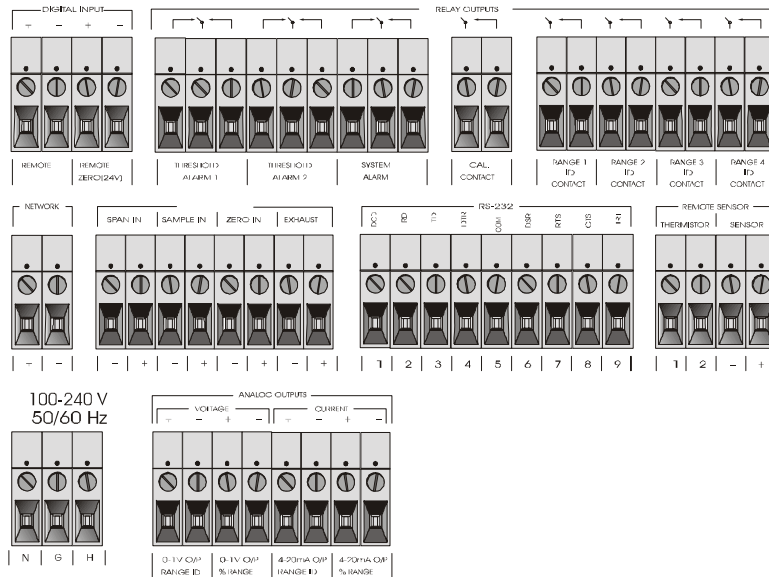

Figure 3-3: Interface Panel of the Model 3010 Control Unit

For safe connections, ensure that no uninsulated wire extends outside of the terminal blocks that are attached to. Stripped wire ends must insert completely into terminal blocks. No uninsulated wiring should be able to come in contact with fingers, tools or clothing during normal operation.

Primary Input Power: The universal power supply requires a 100-240V ac, 50/60 Hz power source. See Figure 3-4 for detailed connections.

DANGER: *Power is applied to the instrument's circuitry as long as the instrument is connected to the power source. The standby function switches power on or off to the displays and outputs only.*

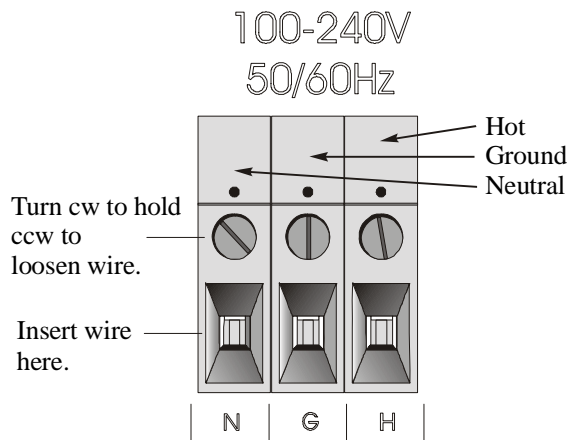

Figure 3-4: Primary Input Power Connections

Fuse Installation: The fuse holders accept 5 x 20 mm, 1.0 A, T type (slow blow) fuses. Fuses are not installed at the factory. Be sure to install the proper fuse as part of installation (See *Fuse Replacement* in chapter 5, *maintenance*.)

Analog Outputs: There are eight DC output signal connectors on the ANALOG OUTPUTS terminal block. There are two connectors per output with the polarity noted. See Figure 3-5.

The outputs are:

- 0–1 V dc % of Range: Voltage rises linearly with increasing oxygen, from 0 V at 0% to 1 V at 100%. (Full scale = 100% programmed range.)
- 0–1 V dc Range ID: 0.25 V = Low Range, 0.5 V = Medium Range, 0.75 V = High Range, 1 V = Air Cal Range.

- 4–20 mA dc % Range: (-M Option) Current increases linearly with increasing oxygen, from 4 mA at 0% to 20 mA at full scale 100%. (Full scale = 100% of programmed range.)
- 4–20 mA dc Range ID: (-M Option) 8 mA = Low Range, 12 mA = Medium Range, 16 mA = High Range, 20 mA = Air Cal Range.

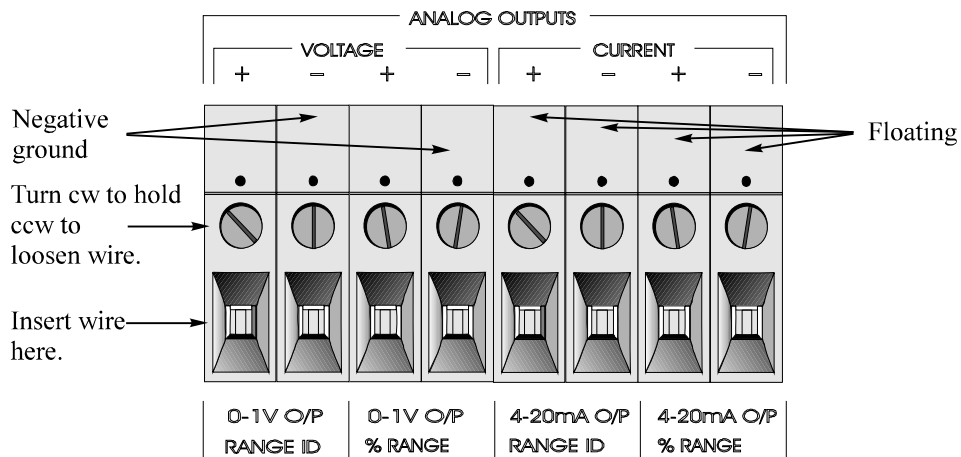

Figure 3-5: Analog Output Connections

Examples:

The analog output signal has a voltage which depends on the oxygen concentration AND the currently activated analysis range. To relate the signal output to the actual concentration, it is necessary to know what range the instrument is currently on, especially when the analyzer is in the autoranging mode.

The signal output for concentration is linear over currently selected analysis range. For example, if the analyzer is set on a range that was defined as)-10 % O₂, then the output would be as shown in Table 3-1.

Table 3-1: Analog Concentration Output-Examples

%O ₂	Voltage Signal Output (V dc)	Current Signal Output (mA dc)
0	0.0	4.0
1	0.1	5.6
2	0.2	7.2
3	0.3	8.8
4	0.4	10.4
5	0.5	12.0
6	0.6	13.6
7	0.7	15.2
8	0.8	16.8
9	0.9	18.4
10	1.0	20.0

To provide an indication of the range, a second pair of analog output terminals are used. They generate a steady preset voltage (or current when using the current outputs) to represent a particular range. Table 3-2 gives the range ID output for each analysis range.

Table 3-2: Analog Range ID Output - Example

Range	Voltage (V)	Current (mA)
LO	0.25	8
MED	0.50	12
HI	0.75	16
CAL (0-25%)	1.00	20

Alarm Relays:

There are three alarm-circuit connectors on the alarm relays block (under RELAY OUTPUTS) for making connections to internal alarm relay contacts. Each provides a set of Form C contacts for each type of alarm. Each has both normally open and normally closed contact connections. The contact connections are indicated by diagrams on the rear panel. They are capable of switching up to 3 amperes at 250 V AC into a resistive load (Figure 3-6).

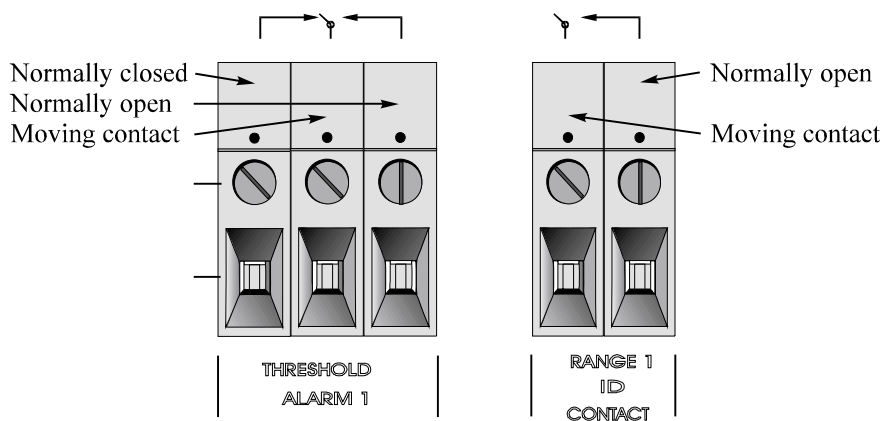

Figure 3-5: Types of Relay Contacts

The connectors are:

- Threshold Alarm 1:
- Can be configured as high (actuates when concentration is above threshold), or low (actuates when concentration is below threshold).
 - Can be configured as fail-safe or non-fail-safe.
 - Can be configured as latching or nonlatching.
 - Can be configured out (defeated).
- Threshold Alarm 2:
- Can be configured as high (actuates when concentration is above threshold), or low (actuates when concentration is below threshold).
 - Can be configured as fail-safe or non-fail-safe.
 - Can be configured as latching or nonlatching.
 - Can be configured out (defeated).
- System Alarm:
- Actuates when DC power supplied to circuits is unacceptable in one or more parameters. Permanently configured as fail-safe and latching. Cannot be defeated. Actuates if self test fails.
- To reset a System Alarm during installation, disconnect power to the instrument and then reconnect it
- Further detail can be found in chapter 4, section 4-5.

Digital Remote Cal Inputs

Remote Zero and Span Inputs: The REMOTE SPAN and REMOTE ZERO inputs are on the DIGITAL INPUT terminal block. They accept 0 V (OFF) or 24 V dc (ON) for remote control of calibration (See *Remote Calibration Protocol* below.)

- Zero: Floating input. 5 to 24 V input across the + and – terminals puts the analyzer into the **ZERO** mode. Either side may be grounded at the source of the signal. 0 to 1 volt across the terminals allows **ZERO** mode to terminate when done. A synchronous signal must open and close the external zero valve appropriately. See *Remote Probe Connector* at end of section 3.3. (With the -C option, the internal valves automatically operate synchronously.)
- Span: Floating input. 5 to 24 V input across the + and – terminals puts the analyzer into the **SPAN** mode. Either side may be grounded at the source of the signal. 0 to 1 volt across the terminals allows **SPAN** mode to terminate when done. A synchronous signal must open and close the external span valve appropriately. See *Remote Probe Connector* at end of section 3.3. (With the -C option, the internal valves automatically operate synchronously.)

Cal Contact: This relay contact is closed while analyzer is spanning and/or zeroing. (See *Remote Calibration Protocol* below.)

Remote Calibration Protocol: To properly time the Digital Remote Cal Inputs to the Model 3010TB Analyzer, the customer's controller must monitor the Cal Relay Contact.

When the contact is OPEN, the analyzer is analyzing, the Remote Cal Inputs are being polled, and a zero or span command can be sent.

When the contact is CLOSED, the analyzer is already calibrating. It will ignore your request to calibrate, and it will not remember that request.

Once a zero or span command is sent, and acknowledged (contact closes), release it. If the command is continued until after the zero or span is complete, the calibration will repeat and the Cal Relay Contact (CRC) will close again.

For example:

- 1) Test the CRC. When the CRC is open, Send a zero command until the CRC closes (The CRC will quickly close.)
- 2) When the CRC closes, remove the zero command.
- 3) When CRC opens again, send a span command until the CRC closes. (The CRC will quickly close.)

- 4) When the CRC closes, remove the span command.

When CRC opens again, zero and span are done, and the sample is being analyzed.

Note: The Remote Probe connector (paragraph 3.3) provides signals to ensure that the zero and span gas valves will be controlled synchronously. If you have the -C Internal valve option - which includes additional zero and span gas inputs - the 3010TB automatically regulates the zero, span and sample gas flow.

Range ID Relays: Four dedicated RANGE ID CONTACT relays . The first three ranges are assigned to relays in ascending order—Low range is assigned to RANGE 1 ID, Medium range is assigned to RANGE 2 ID, and High range is assigned to RANGE 3 ID. RANGE 4 ID is reserved for the Air Cal Range (25%).

Network I/O: A serial digital input/output for local network protocol. At this printing, this port is not yet functional. It is to be used in future versions of the instrument.

RS-232 Port: The digital signal output is a standard RS-232 serial communications port used to connect the analyzer to a computer, terminal, or other digital device. The pinouts are listed in Table 3-3.

Table 3-3: RS-232 Signals

RS-232 Sig	RS-232 Pin	Purpose
DCD	1	Data Carrier Detect
RD	2	Received Data
TD	3	Transmitted Data
DTR	4	Data Terminal Ready
COM	5	Common
DSR	6	Data Set Ready
RTS	7	Request to Send
CTS	8	Clear to Send
RI	9	Ring Indicator

The data sent is status information, in digital form, updated every two seconds. Status is reported in the following order:

- The concentration in percent
- The range is use (HI< MED< LO)
- The span of the range 0-100%, etc)
- Which alarm - if any - are disabled (AL-x DISABLED)
- Which alarms - if any - are tripped (AL-x ON)

Each status output is followed by a carriage return and line feed.

Three input functions using RS-232 have been implemented to date. They are described in Table 3-4.

Table 3-4: Commands via RS-232 Input

Command	Description
as<enter>	Immediately starts an autospan.
az<enter>	Immediately starts an autozero.
st<enter>	Toggling input. Stops/Starts any status message output from the RS-232, Until st<enter> is sent again.

The RS-232 protocol allows some flexibility in its implementation. Table 3-5 lists certain RS-232 values that are required by the 3010TB.

Table 3-5: Required RS-232 Options

Parameter	Setting
Baud	2400
Byte	8 bits
Parity	none
Stop Bits	1
Message Interval	2 seconds

Remote Sensor and Solenoid Valves: The 3010TB is a single-chassis instrument. However, the REMOTE SENSOR and SOLENOID RETURN connectors are provided for use with a remote sensor and/or sampling system, if desired. See Figure 3-7 and 3-8.

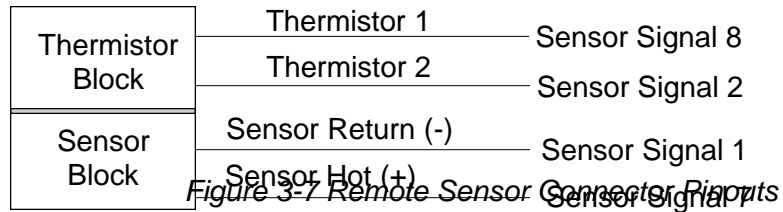

Figure 3-7: Remote Sensor Connector Pinouts

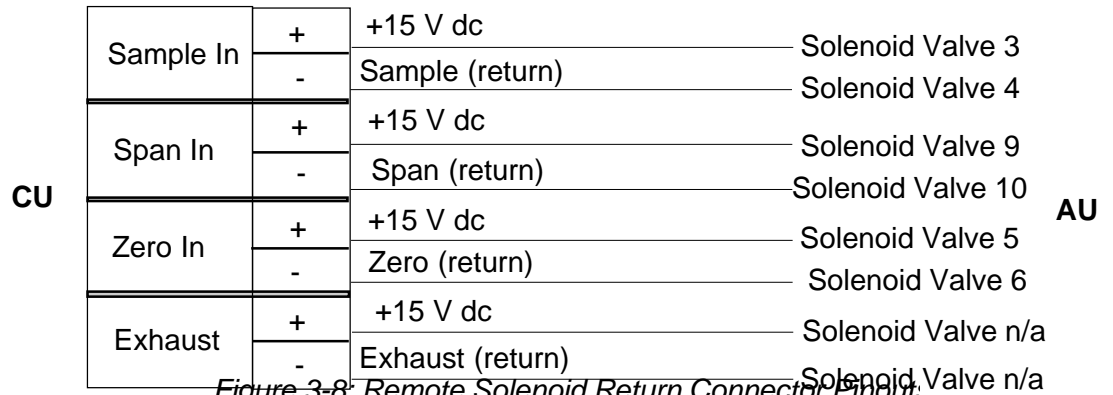

Figure 3-8: Remote Solenoid Return Connector Pinout

The voltage from the solenoid outputs is nominally 0 V for the OFF and 15 V dc for the ON conditions. The maximum combined current that can be pulled from these output lines is 100 mA. (If two lines are ON at the same time, each must be limited to 50 mA, etc.) If more current and/or a different voltage is required, use relays, power amplifiers, or other matching circuitry to provide the actual driving current.

Note that each individual line has a series FET with a nominal ON resistance of 5 ohms (9 ohms worst case). This can limit the obtainable voltage, depending on the load impedance applied. See Figure 3-9.

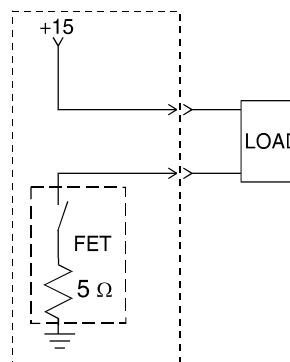

Figure 3-9: FET Series Resistance

3.4 Testing the System

After The Control Unit and the Analysis Unit are **both** installed and interconnected, and the system gas and electrical connections are complete, the system is ready to test. **Before** plugging either of the units into their respective power sources:

- Check the integrity and accuracy of the gas connections. Make sure there are no leaks.
- Check the integrity and accuracy of all electrical connections. Make sure there are no exposed conductors
- Check that sample pressure is between 3 and 40 psig, according to the requirements of your process.

Power up the system, and test it by performing the following operations:

1. Repeat the Self-Diagnostic Test as described in chapter 4, section 4.3.5.

Operation

4.1 Introduction

Once the analyzer has been installed, configure it for your process. To do this you can:

- Set system parameters—
 - Specify a password, if desired, requiring operator to log in.
 - Establish and start an automatic calibration cycle, if desired.
- Calibrate the instrument.
- Define the three user selectable analysis ranges. Then choose autoranging or select a fixed range of analysis, as required.
- Set alarm setpoints, and modes (latching, failsafe, etc).

Before configuration these default values are in effect:

PARAMETER	DEFAULT
LO Range	100 ppm
MED Range	1000 ppm
HI Range	10,000 ppm
Auto Ranging	ON
Alarm Relays	1000 ppm (Defeated, HI, Not failsafe, Not latching)
Span	000008.00 ppm (Auto, every 0 days at 0 hours)
Zero	(Auto, every 0 days at 0 hours).

If you choose not to use password protection, the default password is automatically displayed on the password screen when you start up, and you simply press *Enter* for access to all functions of the analyzer.

4.2 Using the Data Entry and Function Buttons

Data Entry Buttons: The < > arrow buttons select options from the menu currently being displayed on the VFD screen. The selected option blinks.

When the selected option includes a modifiable item, the $\Delta\nabla$ arrow buttons can be used to increment or decrement that modifiable item.

The *Enter* button is used to accept any new entries on the VFD screen. The *Escape* button is used to abort any new entries on the VFD screen that are not yet accepted by use of the *Enter* button.

Figure 4-1 shows the hierarchy of functions available to the operator via the function buttons. The six function buttons on the analyzer are:

- **Analyze.** This is the normal operating mode. The analyzer monitors the oxygen content of the sample, displays the concentration of oxygen, and warns of any alarm conditions.
- **System.** The system function consists of six subfunctions that regulate the internal operations of the analyzer:
 - Auto-Cal setup
 - Password assignment
 - Self-Test initiation
 - Checking software version
 - Logging out.
- **Zero.** Used to set up a zero calibration.
- **Span.** Used to set up a span calibration.
- **Alarms.** Used to set the alarm setpoints and determine whether each alarm will be active or defeated, HI or LO acting, latching, and/or failsafe.
- **Range.** Used to set up three analysis ranges that can be switched automatically with autoranging or used as individual fixed ranges.

Any function can be selected at any time by pressing the appropriate button (unless password restrictions apply). The order as presented in this manual is appropriate for an initial setup.

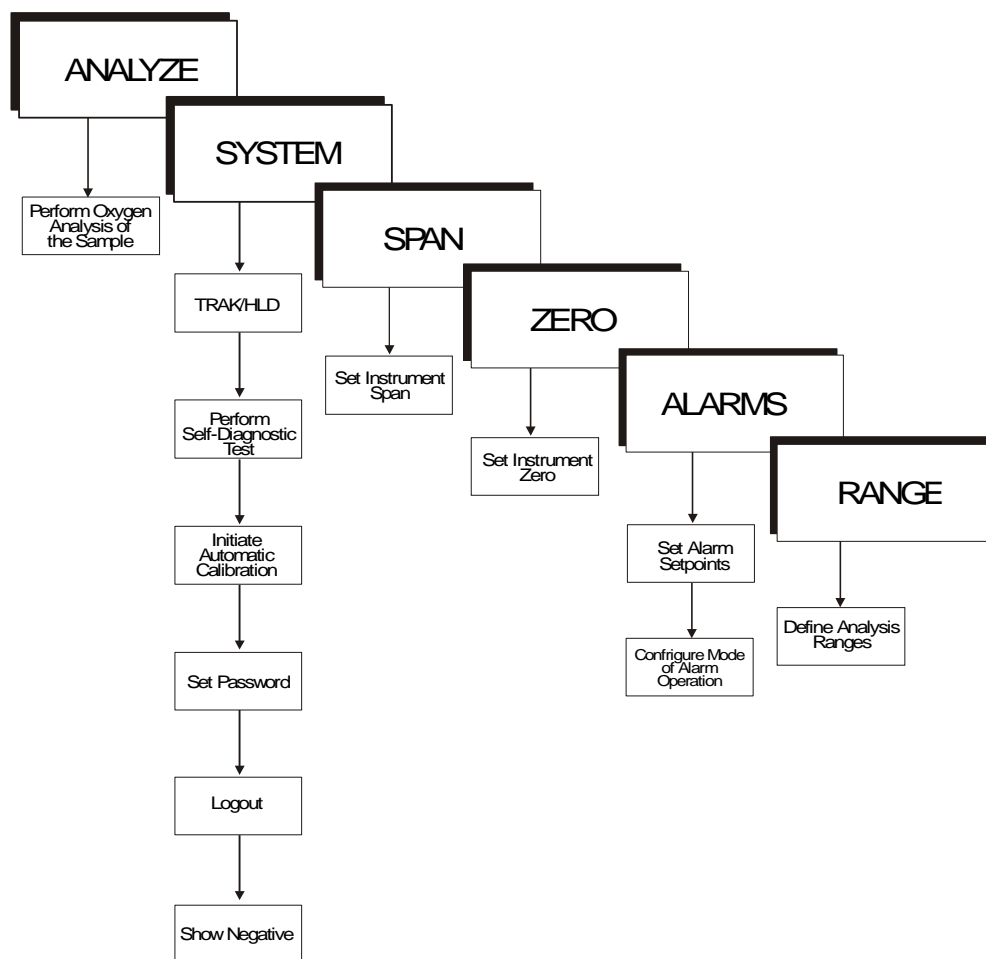

Figure 4-1: Hierarchy of Functions and Subfunctions

Each of these functions is described in greater detail in the following procedures. The VFD screen text that accompanies each operation is reproduced, at the appropriate point in the procedure, in a **Monospaced** type style. Pushbutton names are printed in *Oblique* type.

4.3 The System Function

The subfunctions of the *System* function are described below. Specific procedures for their use follow the descriptions:

- **Auto-Cal:** Used to define an automatic calibration sequence and/or start an Auto-Cal.
- **PSWD:** Security can be established by choosing a 5 digit password (PSWD) from the standard ASCII character set. (See *Installing or Changing a Password*, below, for a table of ASCII characters available.) Once a unique password is assigned and

activated, the operator **MUST** enter the **UNIQUE** password to gain access to set-up functions which alter the instrument's operation, such as setting the instrument span or zero setting, adjusting the alarm setpoints, or defining analysis ranges.

After a password is assigned, the operator must **log out** to activate it. Until then, anyone can continue to operate the instrument without entering the new password.

Only one password can be defined. Before a unique password is assigned, the system assigns TETAI by default. This allows access to anyone. After a unique password is assigned, to defeat the security, the password must be changed back to TETAI.

- **Logout:** Logging out prevents an unauthorized tampering with analyzer settings.
- **More:** Select and enter **More** to get a new screen with additional subfunctions listed.
- **Self-Test:** The instrument performs a self-diagnostic test to check the integrity of the power supply, output boards and amplifiers.
- **Version:** Displays Manufacturer, Model, and Software Version of instrument.
- **Showing Negative:** The operator selects whether display can show negative readings or not.
- **TRAK/HLD:** The operator sets whether the instrument analog outputs track the concentration change during calibration and sets a time delay for the concentration alarms after calibration

4.3.1 Tracking the Oxygen Readings during Calibration and Alarm delay

The user has the option of setting the preference as to whether the analog outputs track the display readings during calibration or not. To set the preference, press the System key once and the first System menu will appear in the VFD display:

```
TRAK/HLD Auto-Cal  
PSWD Logout More
```

TRAK/HLD should be blinking. To enter this system menu press the Enter key once:

```
Output Sttng: TRACK  
Alarm Dly: 10 min
```

Or

Output Sttng: HOLD

Alarm Dly: 10 min

In the first line, TRACK or HOLD should be blinking. The operator can toggle between TRACK and HOLD with the Up or Down keys. When TRACK is selected, the analog outputs (0-1 VDC and 4-20 ma) and the range ID contacts will track the instrument readings during calibration (either zero or span). TRACK is the factory default.

When HOLD is selected, the analog outputs (0-1 VDC and 4-20 ma) and the range ID contacts will freeze on their last state before entering one of the calibration modes. When the instrument returns to the Analyze mode, either by a successful or an aborted calibration, there will be a three-minute delay before the analog outputs and the range ID contacts start tracking again.

The concentration alarms freeze on their last state before entering calibration regardless of selecting HOLD or TRACK. But, when HOLD is selected the concentration alarms will remain frozen for the time displayed in the second line of the TRAK/HLD menu after the analyzer returns to the Analyze mode.

The factory default is three minutes, but the delay time is programmable. To adjust to delay time use the Left or Right arrow keys. When the time displayed on the second line blinks, it can be adjusted by Pressing the Up or Down keys to increase or decrease its value. The minimum delay is 1 minute, the maximum is 30.

This preference is stored in non-volatile memory so that it is recovered if power is removed from the instrument.

4.3.2 Setting up an Auto-Cal

When the proper calibration gases are connected (see chapter 3, *installation*), the Analyzer can cycle itself through a sequence of steps that automatically zero and span the instrument.

Note: If you require highly accurate Auto-Cal timing, use external Auto-Cal control where possible. The internal clock in the Model 3010TB is accurate to 2-3 %. Accordingly, internally scheduled calibrations can vary 2-3 % per day.

To setup an Auto-Cal cycle:

Choose *System* from the Function buttons. The VFD will display five subfunctions.

**TRAK/HLD Auto—Cal
PSWD Logout More**

Use < > arrows to blink Auto—Cal, and press *Enter*. A new screen for Span/Zero set appears.

**Span OFF Nxt: 0d 0h
Zero OFF Nxt: 0d 0h**

Press < > arrows to blink Span (or Zero), then press *Enter* again. (*You won't be able to set OFF to ON if a zero interval is entered.*) A Span Every ... (or Zero Every ...) screen appears.

**Span Every 0 d
Start 0 h from now**

Use $\Delta\nabla$ arrows to set an interval value, then use < > arrows to move to the start-time value. Use $\Delta\nabla$ arrows to set a start-time value.

To turn ON the Span and/or Zero cycles (to activate Auto-Cal): Press *System* again, choose Auto—Cal, and press *Enter* again. When the Span/Zero values screen appears, use the < > arrows to blink the Span (or Zero) OFF/ON field. Use $\Delta\nabla$ arrows to set the OFF/ON field to ON. You can now turn these fields ON because there is a nonzero span interval defined.

4.3.3 Password Protection

If a password is assigned, then setting the following system parameters can be done only after the password is entered: **span** and **zero** settings, **alarm** setpoints, analysis **range** definitions, switching between **autoranging** and manual override, setting up an **auto-cal**, and assigning a new **password**. However, the instrument can still be used for analysis or for initiating a self-test without entering the password.

If you have decided not to employ password security, use the default password TETAI. This password will be displayed automatically by the microprocessor. The operator just presses the Enter key to be allowed total access to the instrument's features.

NOTE: If you use password security, it is advisable to keep a copy of the password in a separate, safe location.

4.3.3.1 Entering the Password

To install a new password or change a previously installed password, you must key in and *ENTER* the old password first. If the default password

is in effect, pressing the *ENTER* button will enter the default TETAI password for you.

Press *System* to enter the *System* mode.

**TRAK/HLD Auto—Cal
PSWD Logout More**

Use the < > arrow keys to scroll the blinking over to PSWD, and press *Enter* to select the password function. Either the default TBEAI password or AAAAA place holders for an existing password will appear on screen depending on whether or not a password has been previously installed.

**T E T A I
Enter PWD**

or

**A A A A A
Enter PWD**

The screen prompts you to enter the current password. If you are not using password protection, press *Enter* to accept TETAI as the default password. If a password has been previously installed, enter the password using the < > arrow keys to scroll back and forth between letters, and the Δ ∇ arrow keys to change the letters to the proper password. Press *Enter* to enter the password.

If the password is accepted, the screen will indicate that the password restrictions have been removed and you have clearance to proceed.

**PSWD Restrictions
Removed**

In a few seconds, you will be given the opportunity to change this password or keep it and go on.

**Change Password?
<ENT>=Yes <ESC>=No**

Press *Escape* to move on, or proceed as in *Changing the Password*, below.

4.3.3.2 Installing or Changing the Password

If you want to install a password, or change an existing password, proceed as above in *Entering the Password*. When you are given the opportunity to change the password:

**Change Password?
<ENT>=Yes <ESC>=No**

Press *Enter* to change the password (either the default TETAI or the previously assigned password), or press *Escape* to keep the existing password and move on.

If you chose *Enter* to change the password, the password assignment screen appears.

T E T A I
<ENT> To Proceed

or

A A A A A
<ENT> To Proceed

Enter the password using the < > arrow keys to move back and forth between the existing password letters, and the $\Delta\nabla$ arrow keys to change the letters to the new password. The full set of 94 characters available for password use are shown in the table below.

Characters Available for Password Definition:

A	B	C	D	E	F	G	H	I	J
K	L	M	N	O	P	Q	R	S	T
U	V	W	X	Y	Z	[¥]	^
_	`	a	b	c	d	e	f	g	h
i	j	k	l	m	n	o	p	q	r
s	t	u	v	w	x	y	z	{	
}	→	!	"	#	\$	%	&	'	(
)	*	+	,	-	.	/	0	1	2
3	4	5	6	7	8	9	:	;	<
=	>	?	@						

When you have finished typing the new password, press *Enter*. A verification screen appears. The screen will prompt you to retype your password for verification.

A A A A A
Retype PWD To Verify

Wait a moment. The entry screen will give you clearance to proceed.

A A A A A
<ENT> TO Proceed

Use the arrow keys to retype your password and press *Enter* when finished. Your password will be stored in the microprocessor and the system will immediately switch to the *Analyze* screen, and you now have access to all instrument functions.

If no alarms are tripped, the *Analyze* screen appears as:

0.0 ppm AnIz
Range: 0 — 100

If an alarm is tripped, the second line will change to show which alarm it is:

0.0 ppm AnIz
AL—1

NOTE: If you previously logged off the system, you will now be required to re-enter the password to gain access to Span, Zero, Alarm, and Range functions.

4.3.4 Logout

The Logout function provides a convenient means of leaving the analyzer in a password protected mode without having to shut the instrument off. By entering Logout, you effectively log off the instrument leaving the system protected against use until the password is reentered. To log out, press the *System* button to enter the *System* function.

TRAK/HLD Auto—Cal
PSWD Logout More

Use the < > arrow keys to position the blinking over the Logout function, and press *Enter* to Log out. The screen will display the message:

Protected Until
Password Reentered

4.3.5 System Self-Diagnostic Test

The Model 3010TB has a built-in self-diagnostic testing routine. Pre-programmed signals are sent through the power supply, output board and sensor circuit. The return signal is analyzed, and at the end of the test the status of each function is displayed on the screen, either as OK or as a number between 1 and 3. (See *System Self Diagnostic Test* in chapter 5 for number code.)

Note: Remote Probe connector must be connected to the Analysis Unit, or sensor circuit will not be properly checked.

The self diagnostics are run automatically by the analyzer whenever the instrument is turned on, but the test can also be run by the operator at will. To initiate a self diagnostic test during operation:

Press the *System* button to start the *System* function.

**TRAK/HLD Auto—Cal
PSWD Logout More**

Use the < > arrow keys to blink *More*, then press *Enter*.

Version Self—Test

Use the < > arrow keys again to move the blinking to the *Self—Test* function. The screen will follow the running of the diagnostic.

**RUNNING DIAGNOSTIC
Testing Preamp — 83**

During preamp testing there is a countdown in the lower right corner of the screen. When the testing is complete, the results are displayed.

**Power: OK Analog: OK
Preamp: 3**

The module is functioning properly if it is followed by OK. A number indicates a problem in a specific area of the instrument. Refer to chapter 5 *Maintenance* for number-code information. The results screen alternates for a time with:

**Press Any Key
To Continue...**

Then the analyzer returns to the initial *System* screen.

4.3.6 Version Screen

Move the < > arrow key to *More* and press *Enter*. With *Version* blinking, press *Enter*. The screen displays the manufacturer, model, and software version information.

4.3.7 Showing Negative Oxygen Readings

For software version 1.4.4 or later, the instrument only displays oxygen readings that are positive or zero. The instrument can be reconfigured to show negative readings if sensor output drifts below zero. This situation may arise after the instrument has been zeroed, as time progresses the sensor may drift below the zero calibration setpoint.

To show negative oxygen readings on the display:

- Press the *System* key

**TRAK/HLD Auto-Cal
PSWD Logout More**

- Use the Right or Left arrow keys and select More. *Press Enter.*

**Version Self-Test
Show_Negative=NO**

- Use the Right or Left arrow keys and select “Show_Negative=NO”.
- Use the Up or Down key to toggle from NO to YES.
- Press the *Escape* key twice to return to the analyze mode.

This preference is stored in non-volatile memory, so this configuration is remembered after a power shutdown. If the instrument is cold started, it will go back to default (not showingg negative oxygen readings).

4.4 The *Zero* and *Span* Functions

Zeroing is not required in order to achieve the published accuracy specification of this unit.

Zeroing will eliminate offset error contributed by sensor, electronics, and internal and external sampling system and improve performance beyond published specification limits.

The analyzer is calibrated using zero and span gases.

Any suitable oxygen-free gas can be used for zero gas as long as it is known that it will not react adversely with the sample system.

Although the instrument can be spanned using air, a span gas with a known oxygen concentration in the range of 70–90% of full scale of the range of interest is recommended. Since the oxygen concentration in air is 20.9 % (209,000 ppm), the cell can take longer to recover if the instrument is used for trace or less than 1% full scale oxygen analysis immediately following calibration in air.

Connect the calibration gases to the analyzer according to the instructions given in Section 3.4.1, *Gas Connections*, observing all the prescribed precautions.

Shut off the gas pressure before connecting it to the analyzer, and be sure to limit the pressure to 40 psig or less when turning it back on.

Readjust the gas pressure into the analyzer until the flowrate (as read on the Analysis Unit SLPM flowmeter) settles between 0.5 and 2.4 SLPM (approximately 1-5 scfh).

If you are using password protection, you will need to enter your password to gain access to either of these functions. Follow the instructions in sections 4.3.3.2 or 4.3.3.3 to enter your password. Once you have gained clearance to proceed, you can enter the *Zero* or *Span* function.

4.4.1 Zero Cal

The *Zero* button on the front panel is used to enter the zero calibration function. Zero calibration can be performed in either the automatic or manual mode. In the **automatic** mode, an internal algorithm compares consecutive readings from the sensor to determine when the output is within the acceptable range for zero. In the **manual** mode, the operator determines when the reading is within the acceptable range for zero. Make sure the zero gas is connected to the instrument. If you get a CELL FAILURE message skip to section 4.4.1.3.

4.4.1.1 Auto Mode Zeroing

Press *Zero* to enter the zero function mode. The screen allows you to select whether the zero calibration is to be performed automatically or manually. Use the $\Delta\nabla$ arrow keys to toggle between AUTO and MAN zero settling. Stop when AUTO appears, blinking, on the display.

Zero: Settling: AUTO
<ENT> To Begin

Press *Enter* to begin zeroing.

PPM Zero
Slope=#### ppm/s

The beginning zero level is shown in the upper left corner of the display. As the zero reading settles, the screen displays and updates information on **Slope** (unless the Slope starts within the acceptable zero range and does not need to settle further).

Then, and whenever Slope is less than 0.08 for at least 3 minutes, instead of Slope you will see a countdown: **5 Left**, **4 Left**, and so fourth. These are five steps in the zeroing process that the system must complete, AFTER settling, before it can go back to *Analyze*.

PPM Zero
4 Left=### ppm/s

The zeroing process will automatically conclude when the output is within the acceptable range for a good zero. Then the analyzer automatically returns to the *Analyze* mode.

4.4.1.2 Manual Mode Zeroing

Press *Zero* to enter the *Zero* function. The screen that appears allows you to select between automatic or manual zero calibration. Use the $\Delta\nabla$ keys to toggle between AUTO and MAN zero settling. Stop when MAN appears, blinking, on the display.

**Zero: Settling: Man
<ENT> To Begin**

Press *Enter* to begin the zero calibration. After a few seconds the first of five zeroing screens appears. The number in the upper left hand corner is the first-stage zero offset. The microprocessor samples the output at a predetermined rate. It calculates the differences between successive samplings and displays the rate of change as Slope= a value in parts per million per second (ppm/s).

**#### ppm Zero
Slope=#### ppm/s**

NOTE: It takes several seconds for the true Slope value to display. Wait about 10 seconds. Then, wait until Slope is sufficiently close to zero before pressing *Enter* to finish zeroing. Slope is given in ppm/s.

Generally, you have a good zero when Slope is less than 0.05 ppm/s for about 30 seconds. When Slope is close enough to zero, press *Enter*. In a few seconds, the screen will update.

Once span settling completes, the information is stored in the microprocessor, and the instrument automatically returns to the *Analyze* mode.

4.4.1.3 Cell Failure

Cell failure in the 3010TB is usually associated with inability to zero the instrument down to a satisfactorily low ppm reading, e.g. cell does not fail if it comes below 5PPM . When this occurs, the 3010TB system alarm trips, and the LCD displays a failure message.

**## ppm Anlz
CELL FAIL/ ZERO HIGH**

Before replacing the cell:

- a. Check your span gas to make sure it is within specifications.
- b. Check for leaks downstream from the cell, where oxygen may be leaking into the system.

- c. Check whether more time is needed for readings to drop to a satisfactory level. This might happen when zero was started from very high PPM level

If there are no leaks and the span gas is OK, replace the cell as described in Part II *Analysis Units*, chapter 5 *Maintenance*.

4.4.2 Span Cal

The *Span* button on the front panel is used to span calibrate the analyzer. Span calibration can be performed using the **automatic** mode, where an internal algorithm compares consecutive readings from the sensor to determine when the output matches the span gas concentration. Span calibration can also be performed in **manual** mode, where the operator determines when the span concentration reading is acceptable and manually exits the function.

4.4.2.1 Auto Mode Spanning

Press *Span* to enter the span function. The screen that appears allows you to select whether the span calibration is to be performed automatically or manually. Use the $\Delta\nabla$ arrow keys to toggle between AUTO and MAN span settling. Stop when AUTO appears, blinking, on the display.

Span: Settling: AUTO
<ENT> For Next

Press *Enter* to move to the next screen.

Calib. Holding time
Cal hold: 5 min

This menu allows the operator to set the time the analyzer should be held in the auto span mode. It does not affect anything in Manual Mode. Just press *Enter* to continue.

Press *Enter* to move to the next screen.

Span Val: 000008.00
<ENT>Span <UP>Mod #

Use the $\Delta\nabla$ arrow keys to enter the oxygen-concentration mode. Use the $\langle \rangle$ arrow keys to blink the digit you are going to modify. Use the $\Delta\nabla$ arrow keys again to change the value of the selected digit. When you have finished typing in the concentration of the span gas you are using (209000.00 if you are using air), press *Enter* to begin the Span calibration.

ppm Span
Slope=#### ppm/s

The beginning span value is shown in the upper left corner of the display. As the span reading settles, the screen displays and updates information on **Slope**. Spanning automatically ends when the span output corresponds, within tolerance, to the value of the span gas concentration. Then the instrument automatically returns to the analyze mode.

4.4.2.2 Manual Mode Spanning

Press *Span* to start the *Span* function. The screen that appears allows you to select whether the span calibration is to be performed automatically or manually.

Span: Settling:MAN
<ENT> For Next

Use the $\Delta\nabla$ keys to toggle between **AUTO** and **MAN** span settling. Stop when **MAN** appears, blinking, on the display. Press *Enter* to move to the next screen.

Press *Enter* to move to the next screen.

Calib. Holding time
Cal hold: 5 min

This menu allows the operator to set the time the analyzer should be held in the auto span mode. It does not affect anything in the Manual Mode. Just press *Enter* to continue.

Span Val: 000008.00
<ENT>Span <UP>Mod #

Press Δ (<UP>) to permit modification (Mod #) of span value.

Use the arrow keys to enter the oxygen concentration of the span gas you are using (209000.00 if you are using air). The < > arrows choose the digit, and the $\Delta\nabla$ arrows choose the value of the digit.

Press *Enter* to enter the span value into the system and begin the span calibration.

Once the span has begun, the microprocessor samples the output at a predetermined rate. It calculates the difference between successive samplings and displays this difference as **Slope** on the screen. It takes several seconds for the first **Slope** value to display. **Slope** indicates rate of change of the **Span** reading. It is a sensitive indicator of stability.

% Span
Slope=#### ppm/s

When the Span value displayed on the screen is sufficiently stable, press *Enter*. (Generally, when the Span reading changes by 1 % or less of the full scale of the range being calibrated for a period of ten minutes it is sufficiently stable.) Once *Enter* is pressed, the Span reading changes to the correct value. The instrument then **automatically** enters the *Analyze* function.

4.4.3 Span Failure

The analyzer checks the output of the cell at the end of the span. If the raw output of the cell is less than 0.5 uA/ppm O₂, the span will not be accepted. The analyzer will return to the previous calibration values, trigger the System Alarm, and display in the VFD:

Span Failed!!

This message will be shown for five seconds and the instrument shall return to the Analyze mode. In the upper right hand corner of the VFD display “FCAL” will be shown. This message flag will help the operator troubleshoot in case calibration was initiated remotely. To reset the alarm and the flag message, the unit must be turned off by cycling the standby key . It will not reset if the next span cycle is correct.

A trace cell is unlikely to fail span. As explained before, when the sensor reaches the end of its useful life, the zero offset begins to rise until the analyzer finds the zero unsatisfactory. Nevertheless, feeding the wrong span gas or electronics failure could set this feature off at the end of the span. Consider this before replacing the cell.

4.5 The Alarms Function

The Model 3010TB is equipped with 2 fully adjustable concentration alarms and a system failure alarm. Each alarm has a relay with a set of form C contacts rated for 3 amperes resistive load at 250 V ac. See figure in chapter 3, *Installation* and/or the Interconnection Diagram included at the back of this manual for relay terminal connections.

The system failure alarm has a fixed configuration described in chapter 3 *Installation*.

The concentration alarms can be configured from the front panel as either *high* or *low* alarms by the operator. The alarm modes can be set as

latching or *nonlatching*, and either *failsafe* or *nonfailsafe*, or, they can be *defeated* altogether. The setpoints for the alarms are also established using this function.

Decide how your alarms should be configured. The choice will depend upon your process. Consider the following four points:

1. Which if any of the alarms are to be high alarms and which if any are to be low alarms?

Setting an alarm as HIGH triggers the alarm when the oxygen concentration rises above the setpoint. Setting an alarm as LOW triggers the alarm when the oxygen concentration falls below the setpoint.

Decide whether you want the alarms to be set as:

- Both high (high and high-high) alarms, or
- One high and one low alarm, or
- Both low (low and low-low) alarms.

2. Are either or both of the alarms to be configured as failsafe?

In failsafe mode, the alarm relay de-energizes in an alarm condition. For nonfailsafe operation, the relay is energized in an alarm condition. You can set either or both of the concentration alarms to operate in failsafe or nonfailsafe mode.

3. Are either of the alarms to be latching?

In latching mode, once the alarm or alarms trigger, they will remain in the alarm mode even if process conditions revert back to no-alarm conditions. This mode requires an alarm to be recognized before it can be reset. In the nonlatching mode, the alarm status will terminate when process conditions revert to no-alarm conditions.

4. Are either of the alarms to be defeated?

The defeat alarm mode is incorporated into the alarm circuit so that maintenance can be performed under conditions which would normally activate the alarms.

The defeat function can also be used to reset a latched alarm. (See procedures, below.)

If you are using password protection, you will need to enter your password to access the alarm functions. Follow the instructions in Section 4.3.3 to enter your password. Once you have clearance to proceed, enter the *Alarm* function.

Press the *Alarm* button on the front panel to enter the *Alarm* function. Make sure that AL-1 is blinking.

AL-1 AL-2
Choose Alarm

Set up alarm 1 by moving the blinking over to AL-1 using the < > arrow keys. Then press *Enter* to move to the next screen.

AL-1 1000 ppm HI
Dft-N Fs-N Ltch-N

Five parameters can be changed on this screen:

- Value of the alarm setpoint, AL-1 ##### (ppm or % oxygen)
- Out-of-range direction, HI or LO
- Defeated? Dft-Y/N (Yes/No)
- Failsafe? Fs-Y/N (Yes/No)
- Latching? Ltch-Y/N (Yes/No).
- To define the setpoint, use the < > arrow keys to move the blinking over to AL-1 #####. Then use the $\Delta \nabla$ arrow keys to change the number. Holding down the key speeds up the incrementing or decrementing. (Remember, setpoint units are parts-per-million.)
- To set the other parameters use the < > arrow keys to move the blinking over to the desired parameter. Then use the $\Delta \nabla$ arrow keys to change the parameter.
- Once the parameters for alarm 1 have been set, press *Alarms* again, and repeat this procedure for alarm 2 (AL-2).
- To reset a latched alarm, go to Dft- and then press either Δ two times or ∇ two times. (Toggle it to **Y** and then back to **N**.)

-OR -

Go to Ltch- and then press either Δ two times or ∇ two times.
(Toggle it to **N** and back to **Y**.)

4.6 The *Range* Function

The Range function allows the operator to program up to three concentration ranges to correlate with the DC analog outputs. If no ranges are defined by the user, the instrument defaults to:

Range	Limits
Low	0-100 ppm
Med	0-1,000 ppm
High	0-10,000 ppm.

The Model 3010TB is set at the factory to default to autoranging. In this mode, the microprocessor automatically responds to concentration changes by switching ranges for optimum readout sensitivity. If the current range limits are exceeded, the instrument will automatically shift to the next higher range. If the concentration falls to below 85% of full scale of the next lower range, the instrument will switch to that range. A corresponding shift in the DC percent-of-range output, and in the range ID outputs, will be noticed.

The autoranging feature can be overridden so that analog output stays on a fixed range regardless of the oxygen concentration detected. If the concentration exceeds the upper limit of the range, the DC output will saturate at 1 V dc (20 mA at the current output).

However, the digital readout and the RS-232 output of the concentration are unaffected by the fixed range. They continue to read accurately with full precision. See *Front Panel* description in chapter 1.

The automatic air calibration range is always 0-25 % and is not programmable.

4.6.1 Setting the Analog Output Ranges

To set the ranges, enter the range function mode by pressing the *Range* button on the front panel.

L—### M—####
H—##### Mode—AUTO

Use the <> arrow keys to blink the range to be set: low (L), medium (M), or high (H).

Use the Δ and ∇ arrow keys to enter the upper value of the range (all ranges begin at 0 ppm). Repeat for each range you want to set. Press *Enter* to accept the values and return to *Analyze* mode. (See note below.)

Note: The ranges must be increasing from low to high, for example, if range 1 is set as 0–100 ppm and range 2 is set as 0–1,000 ppm, range 3 cannot be set as 0–500 ppm since it is lower than range 2.

Ranges, alarms, and spans are always set in ppm units (over the entire 0-250,000 ppm range), even though all concentration-data outputs change from ppm units to percent when the concentration is above 10,000 ppm.

4.6.2 Fixed Range Analysis

The autoranging mode of the instrument can be overridden, forcing the analyzer DC outputs to stay in a single predetermined range.

To switch from autoranging to fixed range analysis, enter the range function by pressing the *Range* button on the front panel.

Use the < > arrow keys to move the blinking over AUTO.

Use the $\Delta \nabla$ arrow keys to switch from AUTO to FX/LO, FX/MED, or FX/HI to set the instrument on the desired fixed range (low, medium, or high).

```
L—###  M—####
H—##### Mode—FX/LO
```

or

```
L—###  M—####
H—##### Mode—FX/MED
```

or

```
L—###  M—####
H—##### Mode—FX/HI
```

Press *Escape* to re-enter the *Analyze* mode using the fixed range.

NOTE: When performing analysis on a fixed range, if the oxygen concentration rises above the upper limit (or default value) as established by the operator for that particular range, the output saturates at 1 V dc (or 20 mA). However, the digital readout and the RS-232 output continue to read the true value of the oxygen concentration regardless of the analog output range.

4.7 The *Analyze* Function

When the *Analyze* function is active, the 3010TB is monitoring the sample gas currently flowing in the Analysis Unit cell block. All undefeated alarms are ready to activate should their respective setpoints be crossed.

Press the *Analyze* button to put the analyzer in the *Analyze* mode.

Normally, all of the functions automatically switch back to the *Analyze* function when they have completed their assigned operations. Pressing the *Escape* button in many cases also switches the analyzer back to the *Analyze* function. Alternatively, you can press the *Analyze* button at any time to return to analyzing your sample.

4.8 Signal Output

The standard Model 3010TB Trace Oxygen Analyzer is equipped with two 0-1 V dc analog output terminals accessible on the interface panel (one concentration and one range ID) and two isolated 4-20 mA dc current outputs (one concentration and one range ID).

See *Rear Panel* in chapter 3, *Installation*, for illustration.

The signal output for concentration is linear over the currently selected analysis range. For example, if the analyzer is set on range that was defined as 0–100 ppm O₂, then the output would be:

ppm O ₂	Voltage Signal Output (V dc)	Current Signal Output (mA dc)
0	0.0	4.0
10	0.1	5.6
20	0.2	7.2
30	0.3	8.8
40	0.4	10.4
50	0.5	12.0
60	0.6	13.6
70	0.7	15.2
80	0.8	16.8
90	0.9	18.4
100	1.0	20.0

The analog output signal has a voltage which depends on the oxygen concentration AND the currently activated analysis range. To relate the signal output to the actual concentration, it is necessary to know what range the instrument is currently on, especially when the analyzer is in the autoranging mode.

To provide an indication of the range, a second pair of analog output terminals are used. They generate a steady preset voltage (or current when using the current outputs) to represent a particular range. The following table gives the range ID output for each analysis range:

Range	Voltage (V)	Current (mA)
LO	0.25	8
MED	0.50	12
HI	0.75	16
CAL (0-25%)	1.00	20

IMPORTANT: In the event of loss of flow through the analyzer, if the vent is vented to a location of high oxygen content, oxygen will back diffuse through the vent line and in most cases quickly saturate the cell with oxygen which can then require a quite long purge down time for the sensor when then exposed to low oxygen concentrations. In the event that flow is to be interrupted into the analyzer, it is suggested that the user do one of the following:



1. Bag the sensor in nitrogen during this time
2. Install a shut off valve on the vent port of the analyzer or somewhere within the users sample system.

Maintenance



Aside from normal cleaning and checking for leaks at the gas connections, routine maintenance is limited to replacing Micro-Fuel cells and fuses, and recalibration.

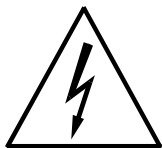

Checking for leaks, replacing Micro-Fuel cells, and replacing fuses in the Analysis Unit are covered in Part II, Chapter 5. For recalibration, see Part I, section 4.4 *Calibration*.

WARNING: SEE WARNINGS ON THE TITLE PAGE OF THIS MANUAL.

5.1 Fuse Replacement

The 3010TB requires two 5 x 20 mm, 1.0 A, T type (Slow Blow) fuses.

The fuses are located inside the main housing on the Electrical Connector Panel, as shown in Figure 5-3. To replace a fuse:

1. Disconnect the Unit from its power source.
2. Place a small screwdriver in the notch in the fuse holder cap, push in, and rotate 1/4 turn. The cap will pop out a few millimeters. Pull out the fuse cap and fuse, as shown in Figure 5-1

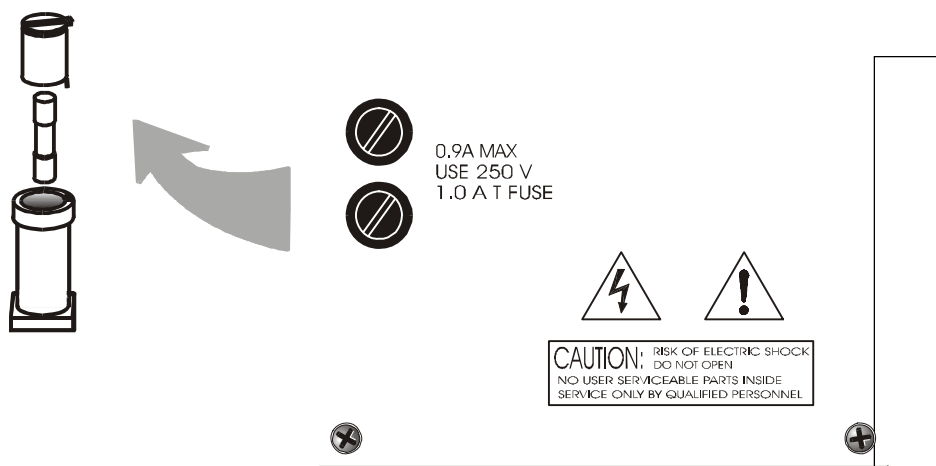

Figure 5-1: Removing Fuse Block Cap and Fuse from Housing

2. Replace fuse by reversing process in step 1.

5.2 System Self Diagnostic Test

1. Press the *System* button to enter the system mode.
2. Use the <> arrow keys to move to More, and press *Enter*.
3. Use the <> arrow keys to move to Self-Test, and press *Enter*.

The following failure codes apply:

Table 5-1: Self Test Failure Codes

Power

0	OK
1	5 V Failure
2	15 V Failures
3	Both Failed

Analog

0	OK
1	DAC A (0–1 V Concentration)
2	DAC B (0–1 V Range ID)
3	Both Failed

Preamp

- 0 OK
- 1 Zero too high
- 2 Amplifier output doesn't match test input
- 3 Both Failed

5.3 Major Internal Components

The major components in the Control Unit are shown in Figure 5-3.

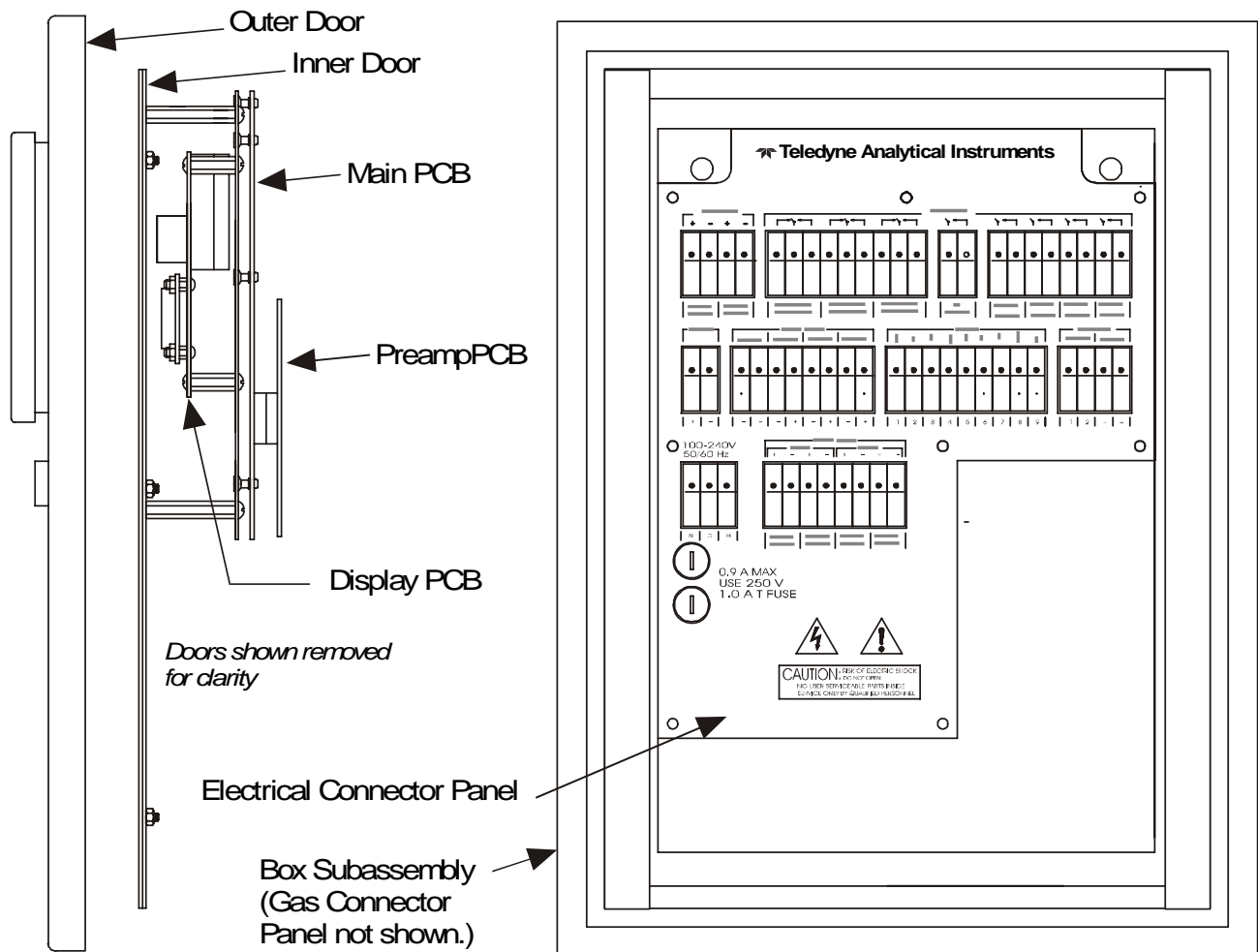

Figure 5-3: Control Unit Major Internal Components

WARNING: HAZARDOUS VOLTAGES EXIST ON CERTAIN COMPONENTS INTERNALLY WHICH MAY PERSIST FOR A TIME EVEN AFTER THE POWER IS TURNED OFF AND DISCONNECTED.

The 3010TB Control Units contain the following major components:

- Power Supply
- Motherboard (with Microprocessor, RS-232 chip, and Preamplifier PCB)
- Front Panel Display Board and Displays—
 - 5 digit LED meter
 - 2 line, 20 character, alphanumeric, VFD display

See the drawings in the Drawings section in back of this manual for details.

OPERATING INSTRUCTIONS

Model 3010TB

Oxygen Analyzer

Part II: Analysis Unit

NEC Type

Part Number D-**65478**

Table of Contents

1 Introduction

1.1 Overview 1-1
1.2 Gas Connector Panel 1-1
1.3 Electrical Connector Panel 1-2

2 Operational Theory

2.1 Introduction 2-1
2.2 Micro-Fuel Cell Sensors 2-1
 2.2.1 Principles of Operation 2-1
 2.2.2 Anatomy of a Micro-Fuel Cell 2-2
 2.2.3 Electrochemical Reactions 2-3
 2.2.4 The Effect of Pressure 2-4
 2.2.5 Calibration Characteristics 2-4
 2.2.6 Micro-Fuel Cell “Class” 2-5
2.3 Sample Systems 2-6

3 Installation

3.1 Unpacking the Analysis Unit 3-1
3.2 Mounting the Analysis Unit 3-1
3.3 Gas Connector Panel Connections 3-3
3.4 Electrical Connector Panel 3-4
3.5 Installing the Micro-Fuel Cell 3-6
3.6 Testing the System 3-6

4 Operation

4.1 Introduction 4-1
4.2 Flowmeter 4-1
4.3 Calibration Gases 4-1
4.4 System Self Diagnostic Test 4-2
4.5 Cell Failure Checks 4-3

5 Maintenance

5.1 Routine Maintenance 5-1

5.2 Major Components 5-1

5.2 Cell Replacement 5-2

 5.2.1 Storing and Handling Replacement Cells 5-2

 5.2.2 When to Replace a Cell 5-3

 5.2.3 Removing the Micro-Fuel Cell 5-4

 5.2.4 Installing a New Micro-Fuel Cell 5-5

 5.2.5 Cell Warranty 5-5

5.3 Fuse Replacement 5-6

5.4 System Self Diagnostic Test 5-6

Introduction

1.1 Overview

The Analytical Instruments Model 3010T Analysis Unit is a versatile remotely controlled instrument for detecting trace amounts of oxygen (0-10 ppm to 0-250 ppm) in a variety of background gases. Details are recorded in *Specifications* in the Appendix to this manual.

Part I of this manual covers the Control Unit. Part II, this part, covers the Model 3010T NEC type explosion proof Analysis Unit only.

1.2 Gas Connector Panel

The standard 3010T Analysis Unit is housed in a NEC type housing with all gas connections accessible from an external connector panel. Figure 1-1 is a cutaway illustration of the Analysis Unit showing the Gas Connector Panel and connectors. The gas connectors are described briefly here and in detail in the *Installation* chapter of this manual.

- **Flowmeter** Monitors the flow of gas past the sensor. Readout is 0.2 to 2.4 standard liters per minute (SLPM).
- **ZERO IN** (On –C Option only) Zero gas inlet. Internally valved. Controlled by Control Unit via Remote Probe connector.
- **SAMPLE IN** Sample gas inlet. Controlled (with –C option) by Control Unit via Remote Probe connector.
- **SPAN IN** (On –C Option only) Span gas inlet. Internally valved. Controlled by Control Unit via Remote Probe connector.
- **EXHAUST** Exhaust gas outlet.

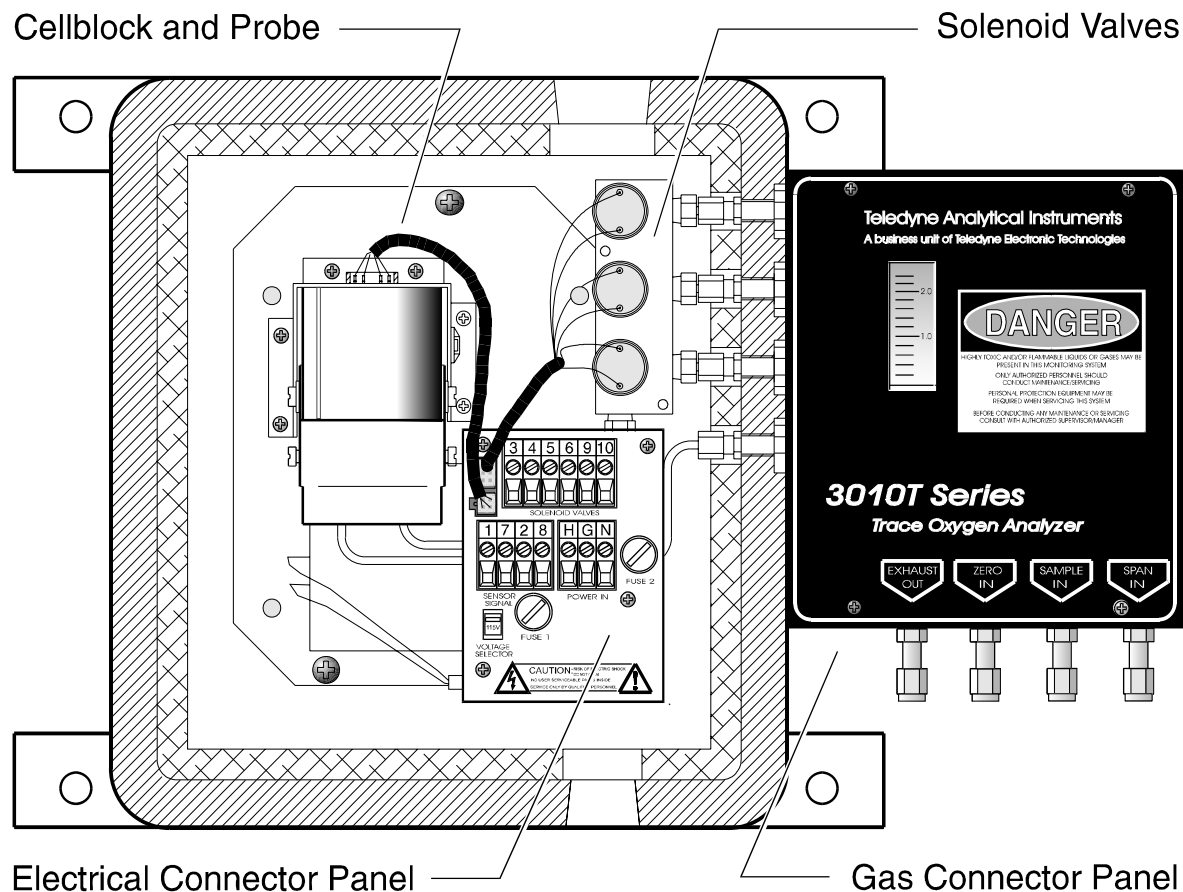

Figure 1-1: Cutaway View of 3010T Analysis Unit

CAUTION: Depending on the user's process, the EXHAUST gas may contain toxic components. In such cases, the exhaust **MUST** vent to a suitably contained area.



1.3 Electrical Connector Panel

Figure 1-2 shows the internal Electrical Connector Panel. Cables enter the housing through access ports (visible in Figure 1-1), and connect to terminals inside the housing. The connectors and controls are described briefly here. They are described in detail in the *Installation*, *Operation*, and *Maintenance* chapters, as appropriate.

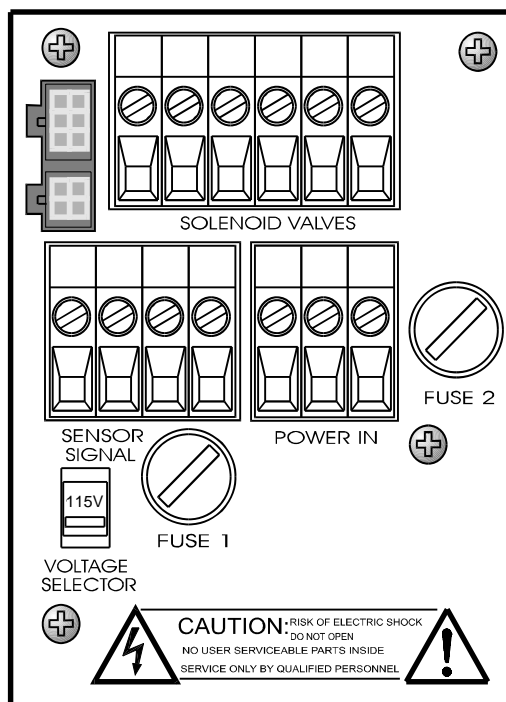

Figure 1-2: Electrical Connector/Control Panel

- Power In** Power input terminals for electric heater. Requires 115 or 230 V ac, depending on position of the Voltage Selector switch. Use 50/60 Hz.

CAUTION: Check the position of the Voltage Selector switch **BEFORE** applying power to the Power Input terminals.

- Voltage Selector** Power input selector switch for electric heater. Adjusts input requirement for 115 or 230 V ac, depending on available source voltage. Use 50/60 Hz.
- Fuses** 1.6 A, 250 V, T type, European size 5 × 20 mm fuses. Fuse 1 is on the neutral side of the line. Fuse 2 is on the hot side of the line.
- Solenoid Valves** Terminals that provide all electrical interconnections from the Control Unit to the gas control valves.
- Sensor Signal** Terminals that provide connections from the Micro-Fuel Cell sensor to the Control Unit.

Operational Theory

2.1 Introduction

The Analysis Unit is composed of two subsystems: the Micro-Fuel Cell sensor and the sample system.

The Micro-Fuel Cell is an electrochemical galvanic device that translates the amount of oxygen present in the sample into an electrical current. The sample system is designed to accept the sample and calibration gasses, select between them (in response to Control Unit signals), and transport the gas through the analyzer—without contaminating or altering its composition before it reaches the sensor.

The electronic signal processing, display, and control systems are housed in the remote Control Unit, covered in Part I of this manual.

2.2 Micro-Fuel Cell Sensor

2.2.1 Principles of Operation

The oxygen sensors used in the Model 3010 series are Micro-Fuel Cells designed and manufactured by Analytical Instruments. They are sealed plastic disposable electrochemical transducers.

The active components of a Micro-Fuel Cell are the cathode, the anode, and the 15% aqueous KOH electrolyte in which they are immersed. The cell converts the energy from a chemical reaction into an electrical current in an external electrical circuit. Its action is similar to that of a battery.

There is, however, an important difference in the operation of a battery as compared to the Micro-Fuel Cell: In the battery, all reactants are stored within the cell, whereas in the Micro-Fuel Cell, one of the reactants (oxygen) comes from outside the device as a constituent of the sample gas being

analyzed. The Micro-Fuel Cell is therefore a hybrid between a battery and a true fuel cell. (All of the reactants are stored externally in a true fuel cell.)

2.2.2 Anatomy of a Micro-Fuel Cell

A Micro-Fuel Cell (MFC) is a cylinder only 1¼ inches in diameter and 1¼ inches thick. It is made of an extremely inert plastic, which can be placed confidently in practically any environment or sample stream. The cell is effectively sealed, although one end is permeable to oxygen in the sample gas. The other end of the cell is a contact plate consisting of two concentric foil rings. The rings mate with spring-loaded contacts in the sensor block assembly and provide the electrical connection to the rest of the analyzer. Figure 2-1 shows the external features of a typical cell.

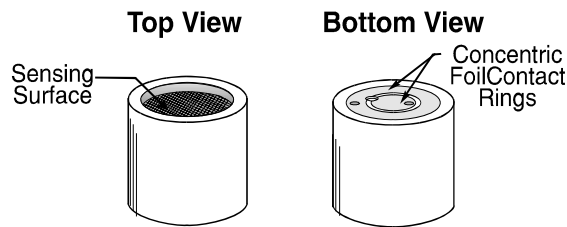

Figure 2-1: Micro-Fuel Cell

Refer to Figure 2-2, *Cross Section of a Micro-Fuel Cell*, which illustrates the following internal description.

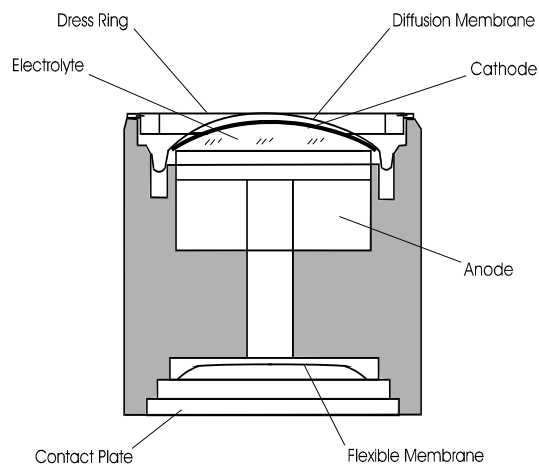

Figure 2-2. Cross Section of a Micro-Fuel Cell (not to scale)

At the top end of the cell is a diffusion membrane of Teflon, whose thickness is very accurately controlled. Beneath the diffusion membrane lies the oxygen sensing element—the cathode—with a surface area almost 4 cm². The cathode has many perforations to ensure sufficient wetting of the upper surface with electrolyte, and it is plated with an inert metal.

The anode structure is below the cathode. It is made of lead and has a proprietary design which is meant to maximize the amount of metal available for chemical reaction.

At the rear of the cell, just below the anode structure, is a flexible membrane designed to accommodate the internal volume changes that occur throughout the life of the cell. This flexibility assures that the sensing membrane remains in its proper position, keeping the electrical output constant.

The entire space between the diffusion membrane, above the cathode, and the flexible rear membrane, beneath the anode, is filled with electrolyte. Cathode and anode are submerged in this common pool. They each have a conductor connecting them to one of the external contact rings on the contact plate, which is on the bottom of the cell.

2.2.3 Electrochemical Reactions

The sample gas diffuses through the Teflon membrane. Any oxygen in the sample gas is reduced on the surface of the cathode by the following HALF REACTION:



(Four electrons combine with one oxygen molecule—in the presence of water from the electrolyte—to produce four hydroxyl ions.)

When the oxygen is reduced at the cathode, lead is simultaneously oxidized at the anode by the following HALF REACTION:

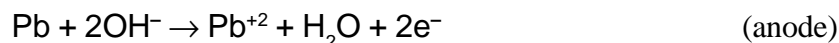

(Two electrons are transferred for each atom of lead that is oxidized. Therefore it takes two of the above anode reactions to balance one cathode reaction and transfer four electrons.)

The electrons released at the surface of the anode flow to the cathode surface when an external electrical path is provided. The current is proportional to the amount of oxygen reaching the cathode. It is measured and used to determine the oxygen concentration in the gas mixture.

The overall reaction for the fuel cell is the SUM of the half reactions above, or:

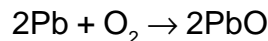

(These reactions will hold as long as no gaseous components capable of oxidizing lead—such as iodine, bromine, chlorine and fluorine—are present in the sample.)

The output of the fuel cell is limited by (1) the amount of oxygen in the cell at the time and (2) the amount of stored anode material.

In the absence of oxygen, no current is generated.

2.2.4 The Effect of Pressure

In order to state the amount of oxygen present in the sample in parts-per-million or a percentage of the gas mixture, it is necessary that the sample diffuse into the cell under constant pressure.

If the total pressure increases, the rate that oxygen reaches the cathode through the diffusing membrane will also increase. The electron transfer, and therefore the external current, will increase, even though the oxygen concentration of the sample has not changed. It is therefore important that the sample pressure at the fuel cell (usually vent pressure) remain relatively constant between calibrations.

2.2.5 Calibration Characteristics

Given that the total pressure of the sample gas on the surface of the Micro-Fuel Cell input is constant, a convenient characteristic of the cell is that the current produced in an external circuit is directly proportional to the rate at which oxygen molecules reach the cathode, and this rate is directly proportional to the concentration of oxygen in the gaseous mixture. In other words it has a linear characteristic curve, as shown in Figure 2-3. Measuring circuits do not have to compensate for nonlinearities.

In addition, since there is almost no output in the absence of oxygen, the characteristic curve has close to an absolute zero—within ± 1 ppm oxygen. (The electronics is zeroed automatically when the instrument power is turned on.)

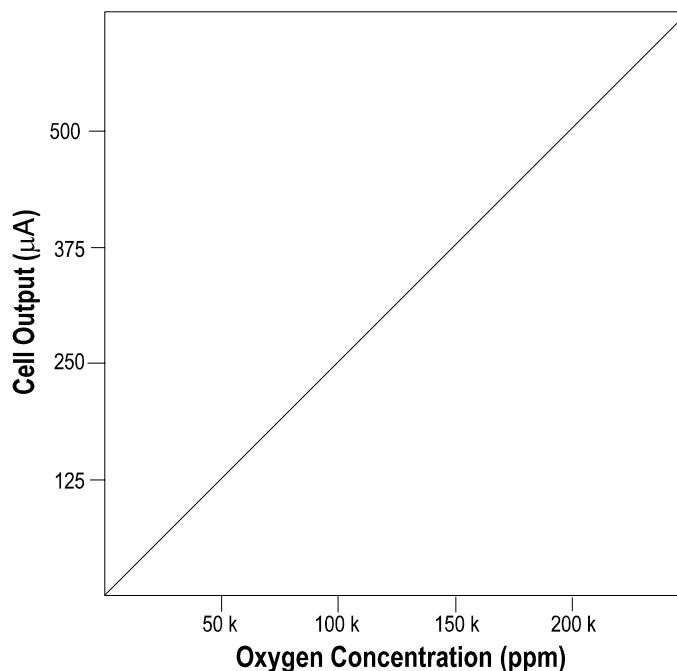

Figure 2-3. Characteristic Input/Output Curve for a Micro-Fuel Cell

2.2.6 Micro-Fuel Cell “Class”

Analytical Instruments manufactures Micro-Fuel Cells with a variety of characteristics to give the best possible performance for any given application. Each unique cell type is given an alphanumeric designation consistent with its application. This designation is its “class.”

2.2.6.1 Hydrogen and/or Helium Service

If the sample gas contains 10 % or more hydrogen and/or helium, only “clamp” cells are used. These Micro-Fuel cells are identified by the suffix -C added to the cell class number.

2.2.6.2 Class L-2C Cell

The class L-2C cell is for general purpose, and hydrogen/helium service, trace oxygen analysis, where the slightly larger size of the cell is acceptable to obtain a longer life than is available with the standard size cell.

Nominal output in air is 0.5 mA, and 90 % response time is 7 s. Expected life is 12 months.

2.3 Sample System

The sample system delivers gases to the Micro-Fuel Cell sensor from the Analysis Unit Gas Control Panel inlets. Depending on the mode of operation either sample or calibration gas is delivered.

Figure 2-4 is a typical flow diagram for the sampling system. The flame arrestors and valves (shaded) are optional.

When the -C option is ordered, the valves are installed inside the 3010 enclosure and are regulated by the remote Control Unit electronics.

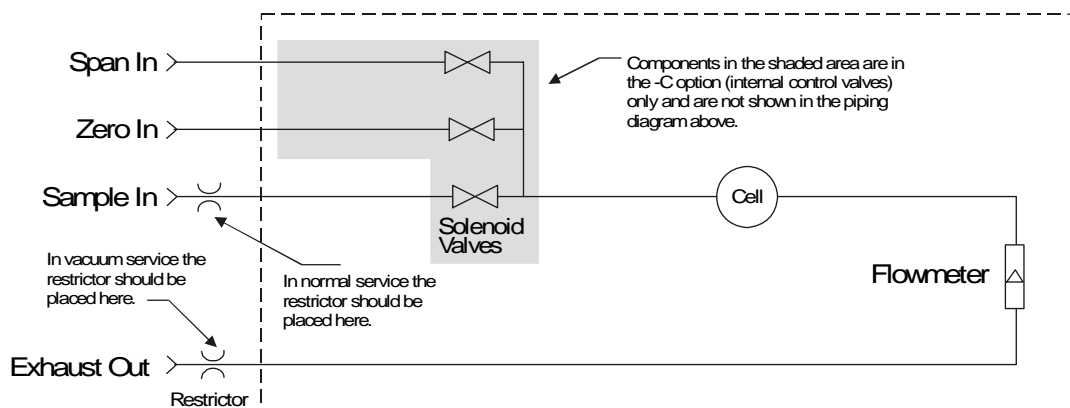

Figure 2-4: Flow Diagram

The Model 3010T sample system is designed and built to ensure that the oxygen concentration of the gas is not altered as it travels through the sample system. The sample encounters almost no dead space. This minimizes residual gas pockets that can interfere with trace analysis.

The metal restrictor upstream from the cell helps manage the flow through the system (1 SLPM at 20 psig for nitrogen). It is corrosion and blockage resistant.

The sample or calibration gas flowing through the system is monitored by a flowmeter downstream from the cell. The sample system for the standard instruments incorporates 1/4 inch tube fittings for sample inlet and outlet connections on the Gas Control Panel. For metric system installations, 6 mm adapters are supplied.

For **-Vacuum Service**, the restrictor is located downstream of the flowmeter. The restrictor is installed in the exhaust port on the gas panel.

Installation

Installation of the Model 3010T Analyzer includes:

1. Unpacking, mounting, and interconnecting the Control Unit and the Analysis Unit
2. Making gas connections to the system
3. Making electrical connections to the system
4. Testing the system.

3.1 Unpacking the Analysis Unit

The analyzer is shipped with all materials needed to install and prepare the system for operation. Carefully unpack the Analysis Unit and inspect it for damage. Immediately report any damage to the shipping agent.

3.2 Mounting the Analysis Unit

The Model 3010T Analysis Unit is for use in Class 1, Division 1, Groups C and D, hazardous environments (group B available).

The standard model is designed for bulkhead mounting. Overall dimensions of the Analysis Unit will vary slightly (less than an inch) due to variations in dimensions of the main explosion-proof enclosure. The maximum footprint will be 19" × 12", and maximum height 9.4". **Outline Drawing D-65478, at the back of this manual, gives the correct mounting dimensions for your unit.**

Note: The housing, including the cover, protrudes 8.6 to 9.4 inches from the base on which it is mounted. Enough clearance is required in front of the cover to allow the cover to be removed and to withdraw the Micro-Fuel Cell for replacement. Cell replacement, with an exploded view of the cell block, is described in chapter 5 *Maintenance*.

Figure 3-1 is a view with the cover removed showing the external Gas Connector Panel and the internal Electrical Connector Panel.

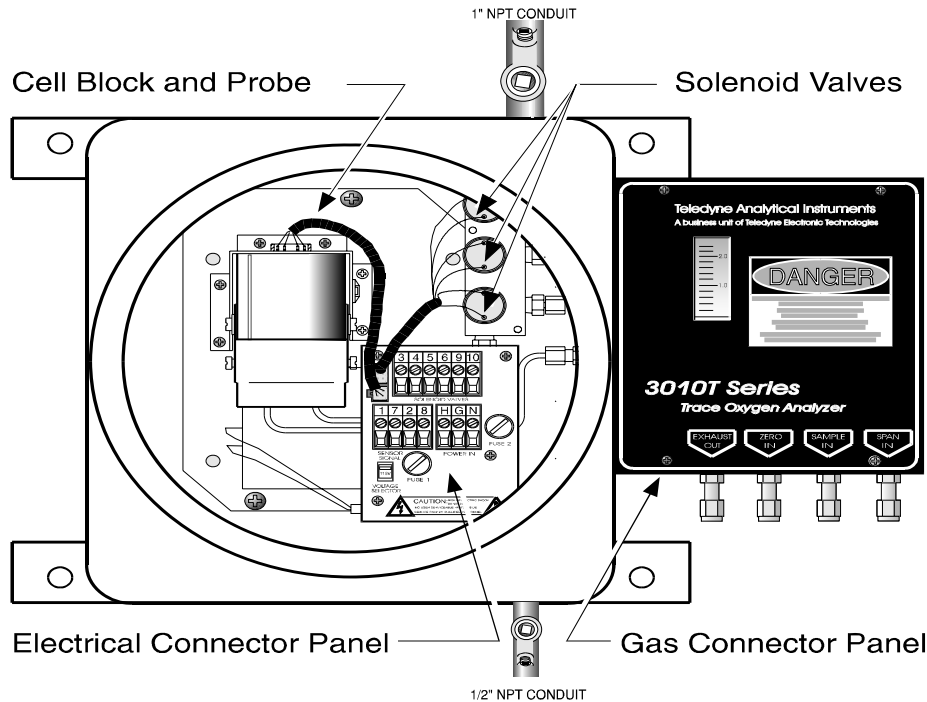

Figure 3-1: View of Analysis Unit Showing Connector Panels

3.3 Gas Connector Panel Connections

Before using this instrument, it should be determined if the unit will be used for pressurized service or vacuum service and low pressure applications. Inspect the restrictor kit that came with the unit. The kit consists of two restrictors and a union for 1/4" diameter tubing. Notice that the two 1 3/4" long, 1/4" diameter tubing are restrictors. It has an open end and a closed end with a small circular orifice. The restrictor without the blue sticker is for low pressure and vacuum service. For high pressure (5 to 50 psig) applications, use the restrictor that has a blue sticker on the body.

For pressurized service, use the restrictor without the blue dot and union from the restrictor kit and attach it to the Sample In port. The small circular orifice should face away from the back of the unit (against the direction of gas flow). Use the restrictor without the blue dot sticker in the same manner for low pressure applications (less than 5 psig).

For vacuum service, use the restrictor without the blue dot sticker and union but attach it to the Exhaust Out port. The small circular orifice should face toward the back of the unit (against the direction of gas flow).

Remove the blue sticker from the restrictor before using.

WARNING: Operating the unit without restrictors can cause damage to the micro-fuel cell.

Figure 3-2 shows the Model 3010T Gas Connector panel. There are inlets for zero, sample and span gas input, and an outlet for exhaust gasses.

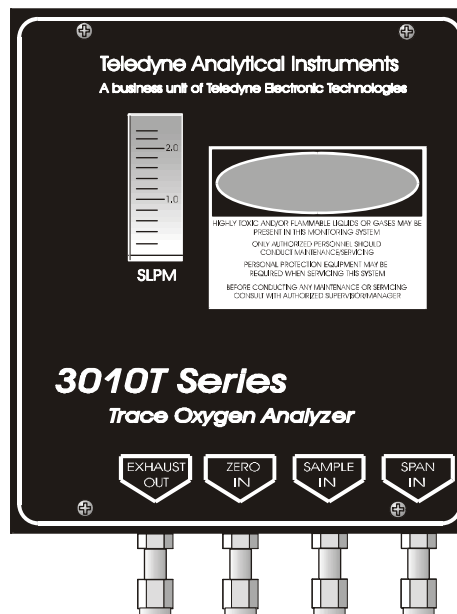

Figure 3-2: Gas Connector Panel

The unit is manufactured with 1/4 inch tube fittings, and 6 mm adapters are supplied for metric system installations. For a safe connection:

1. Insert the tube into the tube fitting, and finger-tighten the nut until the tubing cannot be rotated freely, by hand, in the fitting. (This may require an additional 1/8 turn beyond finger-tight.)

2. Hold the fitting body steady with a backup wrench, and with another wrench rotate the nut another 1¹/₄ turns.

The gas pressure should be reasonably regulated. Pressures between 3 and 40 psig are acceptable as long as the pressure, once established, will keep the flowmeter reading in an acceptable range (0.1 to 2.4 SLPM). Exact figures will depend on your process.

If greater flow is required for improved response time, install a bypass in the sampling system upstream of the analyzer input.

SAMPLE IN: This is the inlet for sample gas. It feeds into an electrically operated valve, inside the housing, that controls the flow of the span gas. The valve is completely under control of the 3010T Control Unit. It can be externally controlled only indirectly through the Remote Cal Inputs, described below under *Electrical Connector/Control Panel*.

ZERO IN and SPAN IN: These are inlets for zero gas and span gas. There are electrically operated valves inside for automatic switching between sample and calibration gases. These valves are completely under control of the 3010 Control Unit. They can be externally controlled only indirectly through the Remote Cal Inputs, described below.

EXHAUST OUT: Exhaust connections must be consistent with the hazard level of the constituent gases. Check local, state, and federal laws, and ensure that the exhaust vents to an appropriately controlled area.

3.4 Electrical Connector Panel

All electrical connections are made on the internal Electrical Connector Panel, inside the explosion-proof enclosure, illustrated in Figure 3-3. The signals are described in the following paragraphs. Wire size and length are given in the Drawings section at the back of this manual. To access the Panel, remove the explosion-proof cover as described in chapter 5, *Maintenance*. NEVER OPEN THE COVER IN A HAZARDOUS ATMOSPHERE. THE AREA MUST BE DECLARED TEMPORARILY SAFE BY THE PROPER AUTHORITY FIRST.

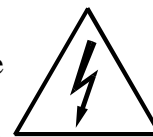

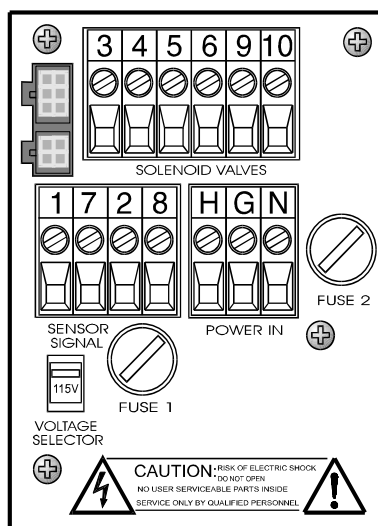

Figure 3-3: Electrical Connector/Control Panel

For safe connections, ensure that uninsulated tips of the wires do not extend beyond the terminal block screws to which they are attached.

Voltage Selector Switch: Set the Voltage Selector switch to the source voltage (115 or 230 V ac) that will be used to power the Analysis Unit internal heater. Make sure the switch is set to the correct voltage **BEFORE** making or energizing the power connections.

Power Connections: 115/230 V ac, 50/ 60 Hz power is required for the heater that keeps the enclosure at a constant temperature. Connect per standard power wiring codes. The connections are—

N Neutral, **G** Ground, **H** Hot.

Fuse Installation: Fuses are not installed at the factory. Be sure to install the proper fuse (5 × 20 mm, 1.6 A) as part of installation. (See *Fuse Replacement* in chapter 5, *Maintenance*.)

Solenoid and Sensor Signal Connections: The Remote Probe connector on the Control Unit (Part I, paragraph 3.3) connects to the Analysis Unit's Solenoid Valves and Sensor Signal terminals. See Figure 3-4. It provides signals to control the solenoid valves which regulate the zero, span and sample gas flow, and accepts the sensor and thermistor signals for processing.

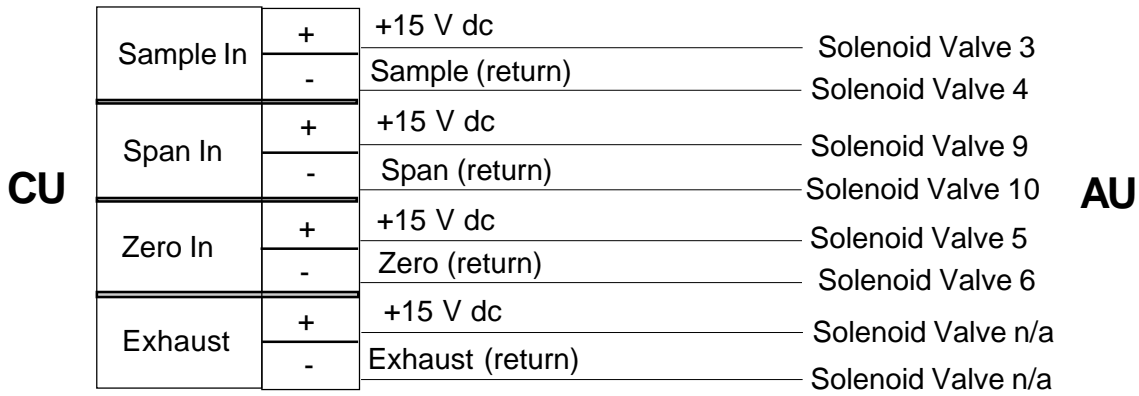

Figure 3-4: Control Unit (CU) to Analysis Unit (AU) Connector Cable

If you use your own gas control valves, use the interconnect diagram in Figure 3-5 for the valves. The sensor and thermistor remain connected as in Figure 3-4, above. (See drawing D-64949 for wire recommendations.)

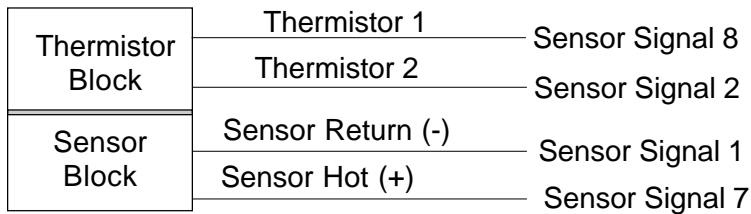

Figure 3-5: Remote Probe Connector Pinouts

The voltage from the solenoid outputs is nominally 0 V for the OFF and 15 V dc for the ON conditions. The maximum combined current that can be pulled from these output lines is 100 mA. (If two lines are ON at the same time, each must be limited to 50 mA, etc.)

If more current and/or a different voltage is required, use a relay, power amplifier, or other matching circuitry to provide the actual driving current. Note that each individual line has a series FET with a nominal ON resistance of 5 ohms (9 ohms worst case). This can limit the obtainable voltage, depending on the load impedance applied. See Figure 3-6.

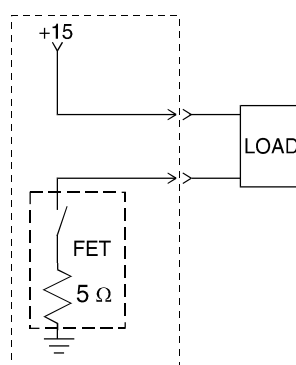

Figure 3-6: FET Series Resistance

3.5 Installing the Micro-Fuel Cell

The Micro-Fuel Cell is not installed in the cell block when the instrument is shipped. It must be installed during initial installation.

Once it is expended, the Micro-Fuel Cell will need to be replaced. The cell could also require replacement if the cell is exposed to air for too long, or if the instrument has been idle for too long.

When the micro-Fuel Cell needs to be installed or replaced, follow the procedures in chapter 5, *Maintenance*, for removing and installing cells.

3.6 Testing the System

After The Control Unit and the Analysis Unit are **both** installed and interconnected, and the system gas and electrical connections are complete, the system is ready to test. **Before** plugging either of the units into their respective power sources:

- Check the integrity and accuracy of the gas connections. Make sure there are no leaks.
- Check the integrity and accuracy of the electrical connections. Make sure there are no exposed conductors
- Check that sample pressure is between 3 and 40 psig, according to the requirements of your process.

Power up the system, and test it as follows:

1. Repeat the Self-Diagnostic Test as described in Part I, chapter 4, section 4.3.5.

Operation

4.1 Introduction

All operation (except observing the **flowmeter**), including testing, and configuring the analyzer to your process/application, is performed from the Control Unit and is described in Part I, Chapter 4 *Operation*, of this manual.

To take advantage of the automatic calibration feature, the proper calibration gases must be connected to Zero and Span ports, and held within the proper pressure range, as described in chapter 3 *Installation*. Calibration gas considerations are reviewed in section 4.3.

Testing consists mostly of running the built-in Self Test, and checking the status of the Micro-Fuel Cell sensor.

4.2 Flowmeter

Although all operation is controlled from the Control Unit, at times during operation or setup it is necessary to observe the flowmeter, which is located on the Analysis Unit. The flowmeter monitors the flow of gas past the Micro-Fuel Cell sensor. The scale on the flowmeter is graduated from 0.2 to 2.4 standard liters per minute (SLPM). Flow readings between 0.1 and 2.4 SLPM are acceptable.

4.3 Calibration Gases

The calibration procedures are described in Part I: Control Units section 4.4, *The Zero and Span Functions*.

The analyzer is calibrated using zero and span gases. Any suitable oxygen-free gas can be used for zero gas as long as it is known to be oxygen free and does not react adversely with the sample system.

Although the instrument can be spanned using air, a span gas with a known oxygen concentration in the range of 70–90% of full scale of the

range of interest is recommended. Since the oxygen concentration in air is 209,000 ppm, the cell can take a long time to recover if the instrument is used for trace oxygen analysis immediately following calibration in air.

Connect the calibration gases to the analyzer according to the instructions given in Section 3.4.1, *Gas Connections*, observing all the prescribed precautions.

Shut off the gas pressure before connecting it to the analyzer, and be sure to limit the pressure to 40 psig or less when turning it back on.

Readjust the gas pressure into the analyzer until the flowrate (as read on the analyzer's SLPM flowmeter) settles between 0.5 and 2.4 SLPM (approximately 1-5 scfh).

Refer to Part I: *Control Units*, section 4.4, *The Zero and Span Functions* for further instructions.

4.4 System Self Diagnostic Test

The self diagnostics are run automatically by the analyzer whenever the instrument is turned on, but the test can also be run by the operator at will. During the test, internal signals are sent through the power supply, output board and sensor circuit automatically. The return signal is analyzed, and at the end of the test the status of each function is displayed on the screen, either as OK or as a number between 1 and 3. (See Table 4-1 for number code.)

Note: Remote Probe connector must be connected to the Analysis Unit, or sensor circuit will not be properly checked.

Instructions for running self diagnostics are repeated here for your convenience:

1. Press the *System* button to enter the system mode.
2. Use the < > arrow keys to move to More, and press *Enter*.
3. Use the < > arrow keys to move to Self-Test, and press *Enter*.

During preamp testing there is a countdown in the lower right corner of the screen. When the testing is complete, the results are displayed.

**Power: OK Analog: OK
Preamp: 3**

The following failure codes apply:

Table 4-1: Self Test Failure Codes**Power**

0	OK
1	5 V Failure
2	15 V Failure
3	Both Failed

Analog

0	OK
1	DAC A (0–1 V Concentration)
2	DAC B (0–1 V Range ID)
3	Both Failed

Preamp

0	OK
1	Zero too high
2	Amplifier output doesn't match test input
3	Both Failed

The results screen alternates for a time with:

**Press Any Key
To Continue...**

Then the analyzer returns to the initial System screen.

4.5 Cell Failure Checks

Cell failure is covered in detail in Part I: *Control Units*, section 4.4.1.3, *Cell Failure*. Cell replacement is covered Part II: *Analysis Units* chapter 5, *Maintenance*.

Cell failure in the 3010T is usually associated with inability to zero the instrument down to a satisfactorily below 5PPM reading. When this occurs, the 3010 system alarm trips, and the VFD displays a failure message.

ppm Anlz

CELL FAIL/ ZERO HIGH

Before replacing the cell:

- Check your span gas to make sure it is within specifications.
- Check for leaks downstream from the cell, where oxygen may be leaking into the system.

- c. Check whether more time is needed for PPM readings to drop to an acceptable level. This is true when coming down from high level.

If there are no leaks and the span gas is OK, replace the cell as described in Part II: *Analysis Units* chapter 5, *Maintenance*.

Maintenance

5.1 Routine Maintenance



Aside from normal cleaning and checking for leaks at the gas connections, routine maintenance is limited to replacing Micro-Fuel cells and fuses, and recalibration.



Self-diagnostic testing of the system and fuse replacement in the Control Unit are covered in Part I, chapter 5 of this manual. For recalibration, see Part I, section 4.4 *Calibration*.

WARNING: SEE WARNINGS ON THE TITLE PAGE OF THIS MANUAL.

5.2 Major Components

The internal components are accessed by rotating the explosion-proof housing cover counterclockwise several turns until free. See Figure 5-1, below. The sampling system gas piping is illustrated in Figure 2-4.

WARNING: SEE WARNINGS ON THE TITLE PAGE OF THIS MANUAL.

The 3010T Analysis Unit contains the following major components:

- Micro Fuel Cell
- Cell block
- Sample system
- Electrical Connector Panel
- Gas Connector Panel (external)

See the drawings in the Drawings section in back of this manual for details.

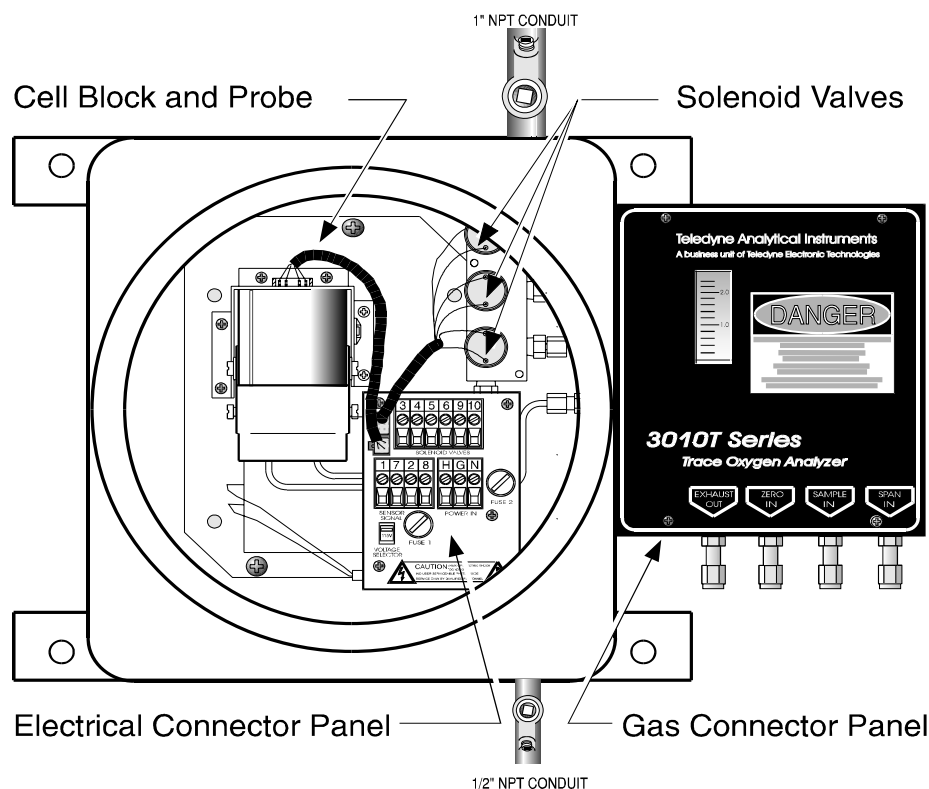

Figure 5-1: Major Components

5.2 Cell Replacement

The Micro-Fuel Cell is a sealed electrochemical transducer with no electrolyte to change or electrodes to clean. When the cell reaches the end of its useful life, it is replaced. The spent fuel cell should be discarded according to local regulations. This section describes storage and handling of the fuel cell, and when and how to replace it.

5.2.1 Storing and Handling Replacement Cells

To have a replacement cell available when it is needed, it is recommended that one spare cell be purchased shortly before the end of the cell's one year warranty period. (Check *Specific Model Information* in The front matter of this manual for which class of cell you purchased.)

CAUTION: Do not stockpile cells. The warranty period starts on the day of shipment.

The spare cell should be carefully stored in an area that is not subject to large variations in ambient temperature (75 °F nominal) or to rough handling.

WARNING: THE SENSORS USED IN THE MODELS 3010T OXYGEN ANALYZERS USE ELECTROLYTES WHICH CONTAIN TOXIC SUBSTANCES, MAINLY LEAD AND POTASSIUM HYDROXIDE, THAT CAN BE HARMFUL IF TOUCHED, SWALLOWED, OR INHALED. AVOID CONTACT WITH ANY FLUID OR POWDER IN OR AROUND THE UNIT. WHAT MAY APPEAR TO BE PLAIN WATER COULD CONTAIN ONE OF THESE TOXIC SUBSTANCES. IN CASE OF EYE CONTACT, IMMEDIATELY FLUSH EYES WITH WATER FOR AT LEAST 15 MINUTES. CALL PHYSICIAN. (SEE APPENDIX, MATERIAL SAFETY DATA SHEET.)

CAUTION: Do not disturb the integrity of the cell package until the cell is to actually be used. If the cell package is punctured and air is permitted to enter, the cell will require an excessively long time to reach zero after installation (as much as a week or more for the L-2C trace oxygen cell!).

5.2.2 When to Replace a Cell

The characteristics of the Micro-Fuel Cell show an almost constant output throughout its useful life and then fall off sharply towards zero at the end. Cell failure in the 3010T is usually characterized inability to zero the instrument down to a satisfactorily low ppm reading. When this occurs, the 3010T system alarm trips, and the VFD displays a failure message.

ppm Anlz

CELL FAIL/ ZERO HIGH

Before replacing the cell:

- a. Check your span gas to make sure it is within specifications.
- b. Check for leaks downstream from the cell, where oxygen may be leaking into the system.
- c. Check whether more time is needed for the PPM readings to drop to an acceptable level (<5PPM).

If there are no leaks and the span gas is OK, replace the cell.

5.2.3 Removing the Micro-Fuel Cell

WARNING: DO NOT TOUCH THE SENSING SURFACE OF THE CELL. IT IS COVERED WITH A DELICATE TEFLON MEMBRANE THAT CAN LEAK CAUSTIC AND CORROSIVE CHEMICALS WHEN PUNCTURED.

The Micro-Fuel cell is located inside the housing in a stainless steel cell block. (See Figure 5-2.)

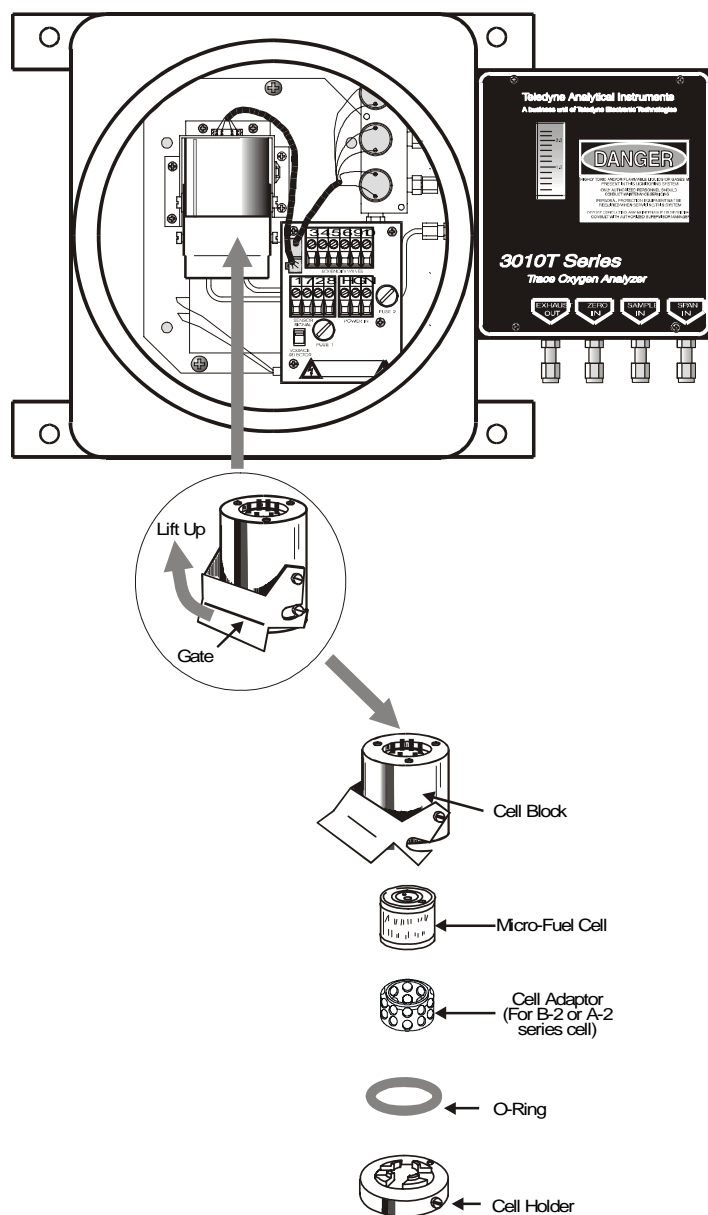

Figure 5-2: Removing or Installing a Trace Micro-Fuel Cell

To remove an existing cell:

1. Remove power to the instrument by unplugging the power cord at the power source.
2. Rotate the housing cover counterclockwise until it is free from the housing, and then removed it.
3. With one hand placed underneath the cell block ready to catch the Micro-Fuel cell, lift up on the stainless steel gate in front of the cell bloc. This releases the cell and cell holder from the block. The cell and holder will fall out in your hand.

5.2.4 Installing a New Micro-Fuel Cell

It is important to minimize the amount of time that a Teledyne Trace Oxygen Sensor is exposed to air during the installation process. The quicker the sensor can be installed into the unit, the faster your TAI O₂ sensor will recover to low O₂ measurement. levels.

CAUTION: Do not touch the sensing surface of the cell. It is covered with a delicate Teflon membrane that can leak when punctured. The sensor must be replaced if the membrane is damaged.



Before installing a new cell, check the O-ring in the base of the cell holder. Replace if worn or damaged.

Place the cell on the holder with the screen side facing down.

Note: There is a small location hole drilled in the holder. This hole mates with a guide pin on the bottom rear of the cell block. The hole in the cell block holder must align with the guide pin on the cell block.

Step 1. Remove power from instrument.

Step 2. Remove the old sensor (if installed) from the analyzer.

Step 3. Purge the analyzer at approximately 1 SCFH flow rate with N₂ (or applicable sample gas with the sensor holder removed).

Step 4. Remove sensor from double bag storage.

Step 5. Remove sensor shorting button.

Step 6. Place sensor on sensor holder so that the gold contact plate of the sensor is facing up towards the sky.

Step 7. Install sensor and sensor holder into cell block.

Step 8. With O-ring in place, align the guide pin with the hole on the cell holder. Then, with the holder, lift cell into the cell block.

Step 9. Push the gate on the cell block down so that the slots on the side of the gate engage the locating screws on the side of the block. This forces the holder into position and forms a gas-tight seal.

Step 10. Purge system with sample or zero gas.

Step 11. Power-up.

If steps 4 through 10 are accomplished quickly (elapsed time less than 15 seconds), recovery to less than 1ppm level should occur in less than 8 hours.

5.2.5 Cell Warranty

The Micro-Fuel cell used in the standard Model 3010T is the L-2C for Trace Analysis. Check *Specific Model Information* in the front matter of this manual for cell class in your unit, if nonstandard, as this will affect cell life and warranty data. Also note any Addenda that may be attached to the front of this manual for special information applying to your instrument.

With regard to spare cells, warranty period begins on the date of shipment. The customer should purchase only one spare cell. Do not attempt to stockpile spare cells.

Note: The L-2C cell is not designed for applications where CO₂ is a major component in the sample, however concentrations of 1,000 ppm or less will not adversely effect the cell performance. Consult TETAI for available options for either intermittent or continuous CO₂ exposure.

If a cell was working satisfactorily, but ceases to function before the warranty period expires, the customer will receive credit toward the purchase of a new cell.

If you have a warranty claim, you must return the cell in question to the factory for evaluation. If it is determined that failure is due to faulty workmanship or material, the cell will be replaced at no cost to you.

Note: Evidence of damage due to tampering or mishandling will render the cell warranty null and void.

5.3 Fuse Replacement

The 3010T Analysis Unit requires two 5 x 20 mm, 1.6 A, T type (Slow Blow) fuses. The fuses are located inside the explosion proof housing on the Electrical Connector Panel, as shown in Figure 5-3. To replace a fuse:

1. Disconnect the Unit from its power source.
2. Place a small screwdriver in the notch in the fuse holder cap, push in, and rotate 1/4 turn. The cap will pop out a few millimeters. Pull out the fuse holder cap and fuse, as shown in Figure 5-3.

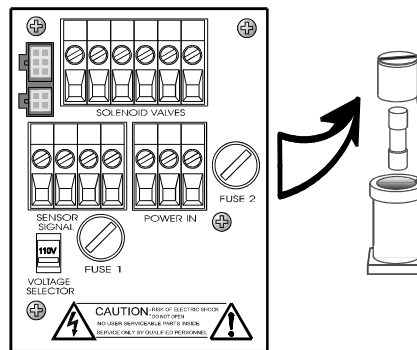

Figure 5-3: Removing Fuse Cap and Fuse from Holder

2. Replace fuse by reversing process in step 1.

5.4 System Self Diagnostic Test

1. Press the *System* button to enter the system mode.
2. Use the <> arrow keys to move to *More*, and press *Enter*.
3. Use the <> arrow keys to move to *Self-Test Diagnostic*, and press *Enter*.
4. Observe the error-code readings on the VFD Display screen, and check Table 5-1, below, to interpret the codes.

Table 5-1: Self Test Failure Codes

Power	
0	OK
1	5 V Failure
2	15 V Failure
3	Both Failed

Analog

- 0 OK
- 1 DAC A (0–1 V Concentration)
- 2 DAC B (0–1 V Range ID)
- 3 Both Failed

Preamp

- 0 OK
- 1 Zero too high
- 2 Amplifier output doesn't match test input
- 3 Both Failed

OPERATING INSTRUCTIONS

Models 3010TB

Oxygen Analyzers

Appendix

NEMA 4 Bulkhead Mount Control Unit PN D66190A
NEC Type Analysis Unit, PN AU**65478**

Contents

A-1 Model 3010TB Specifications A-3
A-2 Recommended 2-Year Spare Parts List A-5
A-3 Drawing List A-6
A-4 Application Notes on Restrictors, Pressures & Flow A-7
A-5 Material Safety Data Sheet A-10

Appendix

A-1 Models 3010TB Specifications

Packaging: General Purpose Control Unit

- Bulkhead Mount NEMA 4 Enclosure

Packaging: Explosion Proof Analysis Unit

Suitable for use in Class 1, Div. 1, Group B, C, & D Hazardous Locations.

NEMA 4 Instrument Enclosure. External gas connector panel with flow indicator (flame arrestors optional).

Sensor: L-2C trace Micro-Fuel Cell.

Cell Block: 316 stainless steel.

Ranges: Three user definable ranges.

0–10 ppm to 0–250,000 ppm.

Air calibration range 0-25 %.

Autoranging with range ID output.

Sample System: Positive pressure service.

Vacuum service (optional).

Auto Cal / Auto Zero with electrically operated valves. (Internal valves optional.)

Alarms: One system-failure alarm-contact to detect power failure.

Two adjustable concentration threshold alarms with fully programmable setpoints.

Diagnostics: Start-up or on-demand, comprehensive, self testing function initiated by keyboard or remote command.

Displays: 2 line by 20 alphanumeric, VFD screen, and one 5 digit LED display. Flowmeter on Analysis Unit.

Digital Interface: Full duplex RS-232 communications port.

Power: General Purpose Control Unit
100-240 VAC
50/60 Hz

Explosion Proof Analysis Unit
115/230 V ac, 50/60 Hz.

Operating Temperature: 0-50 °C

EMF/RFI: Immunity and Emissions designed to meet (but not yet certified to)
EN 50081-1
EN 50082-2.

Accuracy: ±2% of full scale at constant temperature.
±5% of full scale over operating temperature range, on factory default analysis ranges, once thermal equilibrium has been achieved.

Analog outputs: 0-1 V dc percent-of-range
0-1 V dc range ID.
4-20 mA dc percent-of-range
4-20 mA dc range ID.

Password Access: Can be user-configured for password access.

A-2 Recommended 2-Year Spare Parts List

<i>Qty</i>	<i>Part Number</i>	<i>Description</i>
1	D65295B	Customer Interface Board, Control Unit
1	C62371B	Front Panel Board
1	C62368-A	Trace Preamplifier Board
1	C73870-A	Trace Main Computer Board
1	C65407A	Interface Board, Analysis Unit
2	F768	Fuse, 1.6 A, 250 V, 5x20 mm, T—Slow Blow-Analysis Unit
2	F1275	Fuse 1.0A, 5 x 20mm, Slow Blow
1	R1460	Molex Connector for Remote Probe
1	T976	Molex Crimp Terminals for Remote Probe Connector
1	O165	O-ring
1	C6689-L2C	Micro-Fuel Cell

* Order one type only: US or European, as appropriate.

A minimum charge is applicable to spare parts orders.

Note: Orders for replacement parts should include the part number (if available) and the model and serial number of the instrument for which the parts are intended.

Orders should be sent to:

TELEDYNE Analytical Instruments

16830 Chestnut Street
City of Industry, CA 91749-1580

Phone (626) 934-1500, Fax (626) 961-2538
TWX (910) 584-1887 TDYANYL COID

Web: www.teledyne-ai.com

or your local representative.

A-3 Drawing List

D-66190A: Final Assembly, Control Unit.

D-65478: Final Assembly/Outline Drawing, Analysis Unit, Trace Oxygen

D64949: Interconnection Diagram

D64808: Outline Diagram, Control Unit

NOTE: The MSDS on this material is available upon request through the Teledyne Environmental, Health and Safety Coordinator. Contact at (626) 934-1592

A-4**3000 SERIES ANALYZERS
APPLICATION NOTES ON RESTRICTORS,
PRESSURES, AND FLOW RECOMMENDATIONS**

3000 series analyzers require reasonably regulated sample pressures. While the 3000 analyzers are not sensitive to variations of incoming pressure (provided they are properly vented to atmospheric pressure) The pressure must be maintained as to provide a useable flow rate through the analyzer. Any line attached to sample vent should be 1/4 or larger in diameter.

FLOW RATE RECOMMENDATIONS:

A usable flow rate for a 3000 series analyzer is one which can be measured on the flowmeter. This is basically .2 - 2.4 SLPM . The optimum flow rate is 1 SLPM (mid scale). Note: response time is dependent on flow rate, a low flow rate will result in slow response to O₂ changes in the sample stream. The span flow rate should be the approximately same as the sample flow rate.

CELL PRESSURE CONCERNS:

The sensors used in 3000 series analyzers are optimized to function at atmospheric pressure. At pressures other than atmospheric the diffusion rate of O₂ will be different than optimum value. Higher pressures will produce faster O₂ diffusion rates resulting in higher O₂ reading and shorter cell life. To use a 3000 series analyzer at a cell pressure other than atmospheric, the analyzer must be calibrated with a known calibration gas at the new cell pressure to adjust for the different diffusion rate. Cell pressures below 2/3 atmospheric are not recommended because as they tend to cause excessive internal expansion which may result in seal failure.

For operation at cell pressures other than atmospheric care must be taken not to change the sample pressure rapidly or cell damage may occur. For cell pressures above atmospheric, caution must be exercised to avoid over pressuring the cell holder. (percent analyzers will require some type of cell retainer to prevent the cell from being pushed out by the pressure .) For operation at pressures below atmospheric pressure a suffix C (clamped) cell is required.

RESTRICTION DEVICES:

For proper operation, all 3000 series analyzers require a flow restriction device. This device is typically a restrictor or a valve. This restriction device serves two functions in the sample path. The first function is to limit the flow rate of the sample through the analyzer. A restrictor is chosen to operate over a range of pressures and provide a useable flow rate over that range.

The second function that the restriction device provides is a pressure drop. This device is selected to provide the only significant pressure drop in the sample path.

RESTRICTOR KIT

The current revision of the 3000 series analyzers are supplied with a kit containing two restrictors and a union which are user installed. These parts supplied to give the end user more flexibility when installing the analyzer. The restrictor kit is suitable for high and low positive pressure applications as well as vacuum service (atmospheric pressure sample) applications (see manual for installation instructions). The standard restrictor (BLUE DOT) is recommended for pressures between 5 PSIG and 50 PSIG. For positive low pressure application (5 psig or less) the un-marked restrictor is better suited. For non-pressurized sample applications the marked restrictor should be used and configured for vacuum service. Note: for extremely low positive pressure applications (less than 2 psig) the vacuum service configuration should provide higher performance (higher flow rates). For vacuum service the end user must supply a vacuum pump and a by-pass valve for the pump. A vacuum level of 5-10 inches of mercury should provide the optimum flow rate. **CAUTION: flow restrictors have very small orifices and may be plugged by small particles (.005" dia or larger) A sample filter must be included in the sample line prior to the restrictor! (a 60 micron filter is recommended)**

3010TB EXAMPLES:

Example 1, with an incoming pressure of 10 psig the std restrictor (blue dot) will provide a flow rate of .76 SLPM. Up-stream of the restrictor the sample line pressure will be 10 psig, while down stream (including the cell) the pressure will be at atmospheric pressure. (analyzer vented to atmospheric pressure) Note, all other pressure drops in the sample path are insignificant at these flow rates. This insures that the cell operates at atmospheric pressure. At very high flow rates (off scale of flow-meter), pressure drops other than the restriction device could become significant, and result in pressurizing the cell.

Example 2, A 3010TB is configured for vacuum service as follows. The un-marked restrictor is placed in the sample vent port. The down stream end of the restrictor is then connected to a vacuum pump and by-pass valve. The by-pass valve is adjusted to provide a flow rate of 1 SLPM. The sample pressure between the pump and the restrictor will be approximately -7 inches of mercury, while the pressure in the balance of the sample system including the cell will be approximately at atmospheric pressure. (provided the sample flow into the analyzer is not blocked.)

BY-PASS:

To improve the system response, a by-pass can be added to increase the sample flow rate to the analyzer by a factor of ten. A by-pass provides a sample flow path around the analyzer of 2 - 18 SCFH, typically.

CALIBRATION GAS:

3000 series analyzer requirements for units with Auto-Cal options. The customer must supply a control valves (or restrictors) for any SPAN or ZERO gas source which is attached to the Auto-Cal ports. The valve should be adjusted to the same flow rate as the sample gas. When restrictors are used, the gas pressure must be adjusted to achieve the proper flow rate.

OPERATION WITHOUT A RESTRICTOR DEVICE:

Operation without a restrictor device is not recommend as mentioned above. A 3010TB without any flow restrictor device was tested on 11-19-97. This results in a flow rate of 2.4 SLPM @ 1 PSIG. This is a cv of 0.023 for the standard sample sys.

REFERENCE: FLOW_1.XLS & FLOW_2.XLS for information on flow rates at various pressures.

TAI PART NUMBERS

RESTRICTOR KIT:	A68729	
UNION (SS)	U11	
LP.RESTRICTOR	R2323 (LOW PRESSURE / VAC. SERVICE)	
STD..RESTRICTOR	R2324	BLUE DOT
NUT	N73	
FERRULE	F73	
FERRULE	F74	BOTH FERRULES ARE REQUIRED

CONVERSIONS:

1 PSI	=	2.04 INCHES OF MERCURY (in. hg.)
1 SCFH	=	0.476 SLPM

A-4 Material Safety Data Sheet

Section I – Product Identification

Product Name: Micro-Fuel Cells and Super Cells, all classes except A-2C, A-3, and A-5.

Electrochemical Oxygen Sensors, all classes except R-19.

Mini-Micro-Fuel Cells, all classes.

Manufacturer: Teledyne Analytical Instruments

Address: 16830 Chestnut Street, City of Industry, CA 91749

Phone: (818) 961-9221

Customer Service: Extension 222

Environmental Health

and Safety: Extension 230

Date Prepared : 04/26/95

Section II – Hazardous Ingredients/Composition

Material or Component TLV	C.A.S. #	Quantity	OSHA PEL	ACGIH
Lead (Pb)	7439-92-1	3–20 gms	0.05 mg/m ³	0.15 mg/m ³
Potassium Hydroxide Solution 15% (KOH)	1310-58-3	1–5 ml	None	2 mg/m ³

Section III – Physical/Chemical Characteristics

Material Appearance or Component	Boiling Point (°C)	Specific Gravity	Vapor Pressure	Melting Point (°C)	Density	Evap. Rate	Solubility in Water	Odor
Lead	1744	11.34	na	328	na	na	Insoluble	Solid, silver gray, odorless
Potassium Hydroxide	1320	2.04	na	360	na	na	Complete	White or slightly yellow, no odor

Section IV – Fire and Explosion Hazard Data

Flash Point:	na	Flammable Limits:	na	LEL:	na	UEL:	na
Extinguishing Media:	Use extinguishing media appropriate to surrounding fire conditions. No specific agents recommended.						
Special Fire Fighting Equipment:	Wear NIOSH/OSHA approved self-contained breathing apparatus and protective clothing to prevent contact with skin and eyes.						
Unusual Fire and Explosion Hazards:	Emits toxic fumes under fire conditions.						

Section V – Reactivity Data

Stability:	Stable
Incompatibilities:	Aluminum, organic materials, acid chlorides, acid anhydrides, magnesium, copper. Avoid contact with acids and hydrogen peroxide > 52%.
Hazardous Decomposition of Byproducts:	Toxic fumes
Hazardous Polymerization:	Will not occur.
Conditions to Avoid:	

Section VI – Health Hazard Data

Routes of Entry:	Inhalation: Highly unlikely Ingestion: May be fatal if swallowed.
Skin:	The electrolyte (potassium hydroxide) is corrosive; skin contact may cause irritation or chemical burns.
Eyes:	The electrolyte (potassium hydroxide) is corrosive; eye contact may cause irritation or severe chemical burns.
Acute Effects:	The electrolyte is harmful if swallowed, inhaled or adsorbed through the skin. It is extremely destructive to tissue of the mucous membranes, stomach, mouth, upper respiratory tract, eyes and skin.
Chronic Effects:	Prolonged exposure with the electrolyte has a destructive effect on tissue. Chronic exposure to lead may cause disease of the blood and blood forming organs, kidneys and liver, damage to the reproductive systems and decrease in fertility in men and women, and damage to the fetus of a pregnant woman. Chronic exposure from the lead contained in this product is extremely unlikely.

Signs and Symptoms of Exposure:	Contact of electrolyte with skin or eyes will cause a burning sensation and/or feel soapy or slippery to touch. Other symptoms of exposure to lead include loss of sleep, loss of appetite, metallic taste and fatigue.
Carcinogenicity:	Lead is classified by the IARC as a class 2B carcinogen (possibly carcinogenic to humans)
OSHA:	Where airborne lead exposures exceed the OSHA action level, refer to <i>OSHA Lead Standard 1910.1025</i> .
NTP:	na
Medical Conditions Generally Aggravated by Exposure:	Lead exposure may aggravate disease of the blood and blood forming organs, hypertension, kidneys, nervous and possibly reproductive systems. Those with preexisting skin disorders or eye problems may be more susceptible to the effects of the electrolyte.
Emergency First Aid Procedures:	In case of contact with the skin or eyes, immediately flush with plenty of water for at least 15 minutes and remove all contaminated clothing. Get medical attention immediately. If ingested, give large amounts of water and DO NOT INDUCE VOMITING. Obtain medical attention immediately. If inhaled, remove to fresh air and obtain medical attention immediately.

Section VII – Precautions for Safe Handling and Use

NOTE: The oxygen sensors are sealed, and under normal circumstances, the contents of the sensors do not present a health hazard. The following information is given as a guide in the event that a cell leaks.

Protective measures during cell replacement:	Before opening the bag containing the sensor cell, check the sensor cell for leakage. If the sensor cell leaks, do not open the bag. If there is liquid around the cell while in the instrument, wear eye and hand protection.
Cleanup Procedures:	Wipe down the area several times with a wet paper towel. Use a fresh towel each time. Contaminated paper towels are considered hazardous waste.

Section VIII – Control Measures

Eye Protection:	Chemical splash goggles
Hand Protection:	Rubber gloves
Other Protective Clothing:	Apron, face shield
Ventilation:	na

Section IX – Disposal

Both lead and potassium hydroxide are considered poisonous substances and are regulated under TSCA and SARA Title III.

EPA Waste Number:	D008
California Waste Number:	181
DOT Information:	RQ Hazardous Waste Solid N.O.S. (Lead) Class 9 NA3077 PG III
	Follow all Federal, State and Local regulations.

Section X – References

Material Safety Data Sheets from J.T. Baker Chemical, Aldrich, Malinckrodt, ASARCO
U.S. Department of Labor form OMB No. 1218-0072
Title 8 California Code of Regulations
TSCA
SARA Title III
CFR 49
CFR 29
CFR 40

NOTE: The above information is believed to be correct and is offered for your information, consideration, and investigation. It should be used as a guide. Teledyne Analytical Instruments shall not be held liable for any damage resulting from handling or from contact with the above product.