OPERATING INSTRUCTIONS

Model 3010MA

Paramagnetic Oxygen Purity Analyzer



P/N M3010MA
7/01/10

DANGER

Toxic gases and or flammable liquids may be present in this monitoring system.

Personal protective equipment may be required when servicing this instrument.

Hazardous voltages exist on certain components internally which may persist for a time even after the power is turned off and disconnected.

Only authorized personnel should conduct maintenance and/or servicing. Before conducting any maintenance or servicing, consult with authorized supervisor/manager.

Copyright © 2010 TELEDYNE Analytical Instruments

All Rights Reserved. No part of this manual may be reproduced, transmitted, transcribed, stored in a retrieval system, or translated into any other language or computer language in whole or in part, in any form or by any means, whether it be electronic, mechanical, magnetic, optical, manual, or otherwise, without the prior written consent of Teledyne Analytical Instruments, 16830 Chestnut Street, City of Industry, CA 91749-1580.

Warranty

This equipment is sold subject to the mutual agreement that it is warranted by us free from defects of material and of construction, and that our liability shall be limited to replacing or repairing at our factory (without charge, except for transportation), or at customer plant at our option, any material or construction in which defects become apparent within one year from the date of shipment, except in cases where quotations or acknowledgments provide for a shorter period. Components manufactured by others bear the warranty of their manufacturer. This warranty does not cover defects caused by wear, accident, misuse, neglect or repairs other than those performed by Teledyne or an authorized service center. We assume no liability for direct or indirect damages of any kind and the purchaser by the acceptance of the equipment will assume all liability for any damage which may result from its use or misuse.

We reserve the right to employ any suitable material in the manufacture of our apparatus, and to make any alterations in the dimensions, shape or weight of any parts, in so far as such alterations do not adversely affect our warranty.

Important Notice

This instrument provides measurement readings to its user, and serves as a tool by which valuable data can be gathered. The information provided by the instrument may assist the user in eliminating potential hazards caused by his process; however, it is essential that all personnel involved in the use of the instrument or its interface, with the process being measured, be properly trained in the process itself, as well as all instrumentation related to it.

The safety of personnel is ultimately the responsibility of those who control process conditions. While this instrument may be able to provide early warning of imminent danger, it has no control over process conditions, and it can be misused. In particular, any alarm or control systems installed must be tested and understood, both as to how they operate and as to how they can be defeated. Any safeguards required such as locks, labels, or redundancy, must be provided by the user or specifically requested of Teledyne at the time the order is placed.

Therefore, the purchaser must be aware of the hazardous process conditions. The purchaser is responsible for the training of personnel, for providing hazard warning methods and instrumentation per the appropriate standards, and for ensuring that hazard warning devices and instrumentation are maintained and operated properly.

Teledyne Analytical Instruments (TAI) cannot accept responsibility for conditions beyond its knowledge and control. No statement expressed or implied by this document or any information disseminated by the manufacturer or its agents, is to be construed as a warranty of adequate safety control under the user's process conditions.

Safety Messages

Your safety and the safety of others is very important. We have provided many important safety messages in this manual. Please read these messages carefully.

A safety message alerts you to potential hazards that could hurt you or others. Each safety message is associated with a safety alert symbol. These symbols are found in the manual and inside the instrument. The definition of these symbols is described below:



GENERAL WARNING/CAUTION: Refer to the instructions for details on the specific danger. These cautions warn of specific procedures which if not followed could cause bodily injury and/or damage the instrument.



CAUTION: HOT SURFACE WARNING: This warning is specific to heated components within the instrument. Failure to heed the warning could result in serious burns to skin and underlying tissue.



WARNING: ELECTRICAL SHOCK HAZARD: Dangerous voltages appear within this instrument. This warning is specific to an electrical hazard existing at or nearby the component or procedure under discussion. Failure to heed this warning could result in injury and/or death from electrocution.



Technician Symbol: All operations marked with this symbol are to be performed by qualified maintenance personnel only.

NOTE: Additional information and comments regarding a specific component or procedure are highlighted in the form of a note.

CAUTION: THE ANALYZER SHOULD ONLY BE USED FOR THE PURPOSE AND IN THE MANNER DESCRIBED IN THIS MANUAL.



IF YOU USE THE ANALYZER IN A MANNER OTHER THAN THAT FOR WHICH IT WAS INTENDED, UNPREDICTABLE BEHAVIOR COULD RESULT

**POSSIBLY ACCOMPANIED WITH HAZARDOUS
CONSEQUENCES.**

This manual provides information designed to guide you through the installation, calibration and operation of your new analyzer. Please read this manual and keep it available.

Occasionally, some instruments are customized for a particular application or features and/or options added per customer requests. Please check the front of this manual for any additional information in the form of an Addendum which discusses specific information, procedures, cautions and warnings that may be peculiar to your instrument.

Manuals do get lost. Additional manuals can be obtained from Teledyne at the address given in the Appendix. Some of our manuals are available in electronic form via the internet. Please visit our website at: www.teledyne-ai.com.

Table of Contents

Safety Messages	iii
Tables	viii
Figures	ix
Preface	11
Overview	11
Introduction	15
1.1 Overview	15
1.2 Front Panel (Operator Interface)	15
1.3 Rear Panel (Equipment Interface)	17
Operational Theory	19
2.1 Introduction	19
2.2 Electronics and Signal Processing	21
2.5 Temperature Control	22
Installation	25
3.1 Unpacking the Analyzer	25
3.2 Mounting the Analyzer	25
3.3 Rear Panel Connections—Control Unit	28
3.3.1 Gas Connections—Control Unit	28
3.3.2 Electrical Connections—Control Unit	29
3.3.2.1 Primary Input Power	29
3.3.2.2 Fuse Installation	29
3.3.2.3 50-Pin D-Equipment Interface Connector	29
3.3.2.4 RS-232 Port	36
3.4 Installing the Analysis Unit	37
3.5 Rear Panel Connections—Analysis Unit	38
3.5.1 Gas Connections—Analysis Unit	39
3.6 Testing the System	39
Operation	41

4.1	Introduction	41
4.2	Using the Data Entry and Function Buttons	41
4.3	The <i>System</i> Function	43
4.3.1	Setting the Display	44
4.3.2	Setting up an Auto-Cal	44
4.3.3	Password Protection	45
4.3.3.1	Entering the Password	46
4.3.3.2	Installing or Changing the Password	47
4.3.4	Logout	48
4.3.5	System Self-Diagnostic Test	49
4.3.6	Version Screen	50
4.3.7	Display Sensor Output	50
4.4	The <i>Zero</i> and <i>Span</i> Functions	50
4.4.1	Span Cal	51
4.4.1.1	Auto Mode Spanning	51
4.4.1.2	Manual Mode Spanning	52
4.5	The <i>Alarms</i> Function	53
4.6	The <i>Range</i> Function	55
4.6.1	Setting the Analog Output Ranges	56
4.6.2	Autoranging Analysis	56
4.6.3	Fixed Range Analysis	56
4.7	The <i>Analyze</i> Function	57
4.8	Signal Output	57
	Maintenance.....	59
5.1	Routine Maintenance	59
5.2	Fuse Replacement	59
5.3	System Self Diagnostic Test	60
5.4	Major Internal Components	61
5.5	Cleaning	63
	Analysis Unit.....	67
6.1	Overview	67
6.2	Paramagnetic Sensor	68
6.2.1	Principles of Operation	68

Paramagnetic O2 Purity Analyzer

6.2.2 Cross Interference	71
6.3 Oven and Temperature Controller	74
6.4 Sample System	75
6.5 Leak Checking the Analysis Unit	78
6.6 Initial Sensor Calibration	78
Appendix	81
A-1 Model 3010MA Specifications	81
A-2 Recommended 2-Year Spare Parts List	83
A-3 Drawing List	84
A.4 Programmable Pressure Compensation Adjustment	85



Tables

Table 3-1: Analog Output Connections.....	30
Table 3-2: Alarm Relay Contact Pins.....	31
Table 3-3: Remote Calibration Connections.....	32
Table 3-4: Range ID Relay Connections	33
Table 3-5: 50-Pin Equipment Interface Connector	35
Table 3-6: Commands via RS-232 Input	37
Table 3-7: Required RS-232 Options	37
Table 4.1: Linear Analog Output.....	57
Table 4-2: Range ID Output	58
Table 5-1: Self-Test Failure Codes.....	60
Table 6-1: Sensor Cable Pin Configuration	70
Table 6-2: Cross Sensitivity of Various Gases	73
Table 6-3: Pressure Ranges of Available Restrictors	75

Figures

Figure 1-1: Model 3010MA Control Unit Front Panel.....	16
Figure 1-2 Rear Panel of Model 3010MA Control Unit	18
Figure 2-1: Block Diagram for Model 3010MA Control Unit.....	20
Figure 2-2: Block Diagram for Model 3010MA Analysis Unit	20
Figure 2-3: Location of Electronic Components in Control Unit	21
Figure 2-4: Block Diagram of the Model 3010MA Electronics	23
Figure 3-1: Rack Mountable Control and Analysis Units	26
Figure 3-2: Front Panel of the Model 3010MA.....	27
Figure 3-3: Required Front Door Clearance	27
Figure 3-4: Rear Panel of the Model 3010MA Control Unit	28
Figure 3-5: Equipment Interface Connector Pin Arrangement.....	30
Figure 3-6: Remote Valve Connections.....	34
Figure 3-7: FET Series Resistance.....	35
Figure 3-8: Analysis Unit Rear Panel.....	38
Figure 4-1: Hierarchy of Functions Available on the Model 3010MA42	
Figure 5-1: Removing Fuse Block from Housing	59
Figure 5-2: Installing Fuses	60
Figure 5-3: Internal Components of the Control Unit	61
Figure 5-4: Rear-Panel Screws	63
Figure 6-1: Side view of Paramagnetic Sensor	69
Figure 6-2: Front View of the Paramagnetic Sensor.....	69
Figure 6-3: Sensor and Trimpot Identification.....	70
Figure 6-4: 15-Pin Sensor Cable and Pin Identification.....	72
Figure 6-5: Access to Temperature Controller in Control Unit	74
Figure 6-6: Piping Diagram for Model 3010MA	77
Figure 6-7: Analysis Unit Front Panel.....	77

Preface

Overview

The Teledyne Analytical Instruments Model 3010MA Paramagnetic Oxygen Purity Analyzer is a versatile microprocessor-based instrument for analyzing the purity of an oxygen bearing gas stream. It is a “split architecture” instrument designed for indoor use in non-hazardous areas. The Control Unit contains the operator interface, electronics and display. The Analysis Unit is a separate insulated and temperature controlled enclosure which contains the oven, sensor, sample system and flowmeter. The analyzer has three user settable ranges that encompass the complete range of 0-100% oxygen. The ranges can be set to any convenient level between 0 and 100% in one percent increments.

Note: The upper value of every range is non-adjustable and is fixed at 100%. The lower value can be adjusted anywhere from 99% to 0%.

Part I of this manual covers the Model 3010MA flush-panel and/or rack-mount Control Unit. The Analysis Unit is covered in Part II of this manual.

Typical Applications

A few typical applications of the Model 3010MA are:

- Monitoring inert gas blanketing
- Air separation and liquefaction
- Chemical reaction monitoring
- Semiconductor manufacturing
- Petrochemical process control
- Quality assurance
- Gas analysis certification.



Main Features of the Analyzer

The Model 3010MA series Paramagnetic Oxygen Analyzers are sophisticated yet simple to use. The main features of these analyzers include:

- A 2-line alphanumeric display screen, driven by microprocessor electronics, that continuously prompts and informs the operator.
- High resolution, accurate readings of oxygen content
- Paramagnetic oxygen sensor
- Microprocessor based electronics: 8-bit CMOS microprocessor with 32 kB RAM and 128 kB ROM.
- Three user settable analysis ranges allow best match to users process and equipment. Default setting are: 0-100%, 95-100%, and 98-100% oxygen.
- Auto Ranging allows analyzer to automatically select the proper preset range within the 0-100% range of the sensor. Manual override allows the user to lock onto a specific range of interest.
- Two user-adjustable concentration alarms and a system failure alarm.
- Self-diagnostic testing, at startup and on demand, with continuous power-supply monitoring.
- Two way RFI protection.
- RS-232 serial digital port for use with a computer or other digital communications device.
- Analog outputs for Concentration and Analysis Range: 0–1VDC standard. Isolated 4–20 mA dc standard.
- Compact and versatile design—flush-panel, or rack-mountable

OPERATING INSTRUCTIONS

Model 3010MA

Paramagnetic Oxygen Purity Analyzer

Part I: Control Unit

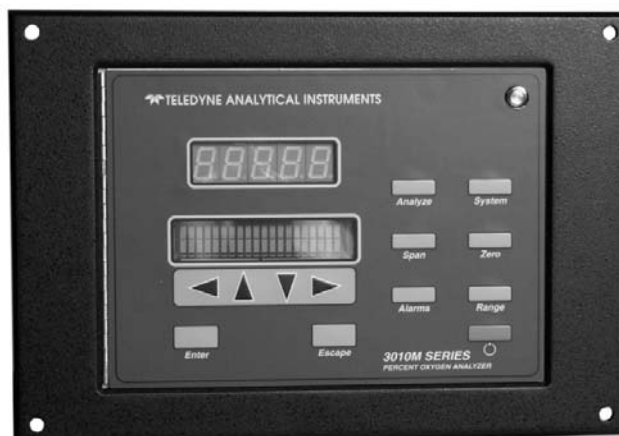

Introduction

1.1 Overview

The Teledyne Analytical Instruments Model 3010MA Paramagnetic Oxygen Purity Analyzer is a versatile microprocessor-based instrument for detecting the percentage of oxygen in a gas stream. This part of the manual covers the Model 3010MA flush-panel and/or rack-mount Control Unit. These units are for indoor use in a nonhazardous environment.

In addition to supplying the interface for operating and controlling the analyzer, the Control Unit also houses:

- Main circuit board
- PID temperature controller
- Pressure compensation circuitry
- 24VDC power supply for driving the Analysis Unit
- Digital meter readout and display circuit board
- Interface screen and circuit board

1.2 Front Panel (Operator Interface)

The standard 3010MA is housed in a rugged metal case with all controls and displays accessible from the front panel. See Figure 1-1. The front panel has thirteen buttons for operating the analyzer, a digital meter, and an alphanumeric display.

Function Keys:

Six touch-sensitive membrane switches are used to change the specific function performed by the analyzer:

- **Analyze**—Perform analysis for oxygen content of a sample gas.
- **System**—Perform system-related tasks (described in detail in chapter 4, *Operation*).
- **Span**—Span calibrate the analyzer.
- **Zero**—Zero calibrate the analyzer.

- **Alarms**—Set the alarm setpoints and attributes.
- **Range**— Set up the 3 user definable ranges for the instrument.

Data Entry Keys:

Six touch-sensitive membrane switches are used to input data to the instrument via the alphanumeric VFD display:

- **Left & Right Arrows**—Select between functions currently displayed on the VFD screen.
- **Up & Down Arrows**—Increment or decrement values of functions currently displayed.
- **Enter**—Moves VFD display on to the next screen in a series. If none remains, returns to the *Analyze* screen.
- **Escape**—Moves VFD display back to the previous screen in a series. If none remains, returns to the *Analyze* screen.

Digital Meter Display:

The meter display is a LED device that produces large, bright, 7-segment numbers that are legible in any lighting environment. It produces a continuous readout of oxygen concentration. It is accurate across all ranges without the discontinuity inherent in analog range switching.

Alphanumeric Interface Screen:

The VFD screen is an easy-to-use interface from operator to analyzer. It displays values, options, and messages that give the operator immediate feedback.

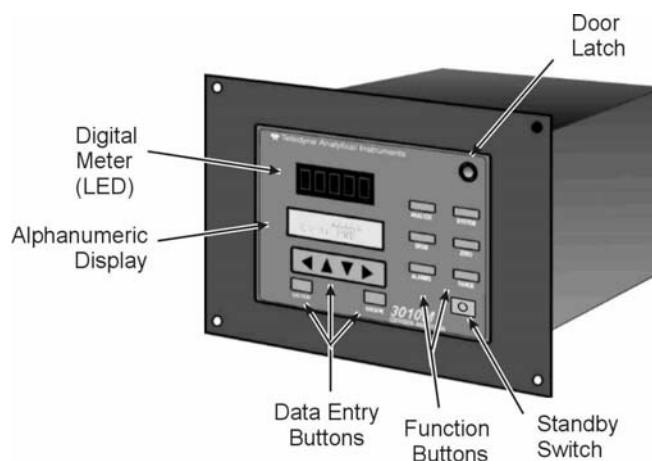

Figure 1-1: Model 3010MA Control Unit Front Panel

Standby Button:

The Standby feature turns off the display and outputs, but circuitry is still operating. It is useful for power saving as well as prolonging the life of the display elements.

WARNING: THE INSTRUMENT IS STILL ENERGIZED WHEN THE STANDBY BUTTON IS PRESSED.



THE POWER CABLE MUST BE UNPLUGGED TO DISCONNECT POWER FROM THE INSTRUMENT. WHEN CHASSIS IS EXPOSED OR WHEN ACCESS DOOR IS OPEN AND POWER CABLE IS CONNECTED, USE EXTRA CARE TO AVOID CONTACT WITH LIVE ELECTRICAL CIRCUITS.

Access Door:

To provide access to the display circuitry, the PID temperature controller or pressure compensation circuitry, the front panel swings open when the latch in the upper right corner of the panel is pressed all the way in with a narrow gauge tool. Accessing the main circuit board requires unfastening the rear panel screws and sliding the unit out of the case.

1.3 Rear Panel (Equipment Interface)

The rear panel of the Model 3010MA Control Unit is shown in Figure 1-2. Connections are made at this panel for power, RS-232 communication, equipment interfacing and connections to the Analysis Unit. The connectors are described briefly here and in detail in the *Installation* chapter of this manual.

- **Power Connection**— AC power source.
- **Pressure In**—1/8" Gas line input to pressure compensation circuit from Analysis Unit.
- **Line voltage**—Selector switch for line voltage 115/230.
- **RS-232 Port**—Serial digital concentration signal output and control input.
- **Sensor In Connector**—15 pin D-connector sensor cable from Analysis Unit, (includes 24VDC power)
- **Heater Out**— 7 pin CPC connector, Power to heater in Analysis Unit

- **Network**—For future expansion. Not implemented at this printing.
- **50-Pin Equipment Interface Connector**—provides access for:
 - **Alarms**—2 concentration and 1 system alarm
 - **Analog Outputs**—0-1VDC concentration and 0-1VDC range ID. 4-20 mA concentration and optional 4-20 mA range ID.
- **Remote Span/Zero**—Digital inputs for external control of analyzer calibration
- **Calibration Contact**—Special contacts to signal that the instrument is being calibrated and not monitoring sample
- **Range ID Contacts**—Separate, dedicated range relay contacts for low medium and high ranges



Figure 1-2 Rear Panel of Model 3010MA Control Unit

Operational Theory

2.1 Introduction

The analyzer is composed of three subsystems:

1. Paramagnetic Sensor
2. Sample System
3. Electronic Signal Processing, Display and Control

The paramagnetic sensor and the sample system are located in the Analysis Unit while the Electronic Signal Processing, Display and Control systems are housed in the Control Unit.

The sample system is designed to accept the sample gas and transport it through the analyzer without contaminating or altering the sample prior to analysis. It is described in detail in Part II Section 6.4 of this manual.

The Analysis Unit is separate from the Control Unit in order to provide critical temperature stability. The paramagnetic sensor is an electromechanical device that translates the amount of oxygen present in the sample into an electrical signal. It is a partial pressure device sensitive to both operating pressure (vent pressure) and temperature fluctuations. The output from the sensor is compensated for pressure variation using a baseline pressure initially set during calibration. Temperature at the sensor is held constant using an 80 Watt heater controlled by a PID temperature controller located in the Control Unit. Feedback from the sensor to the PID controller is supplied by an RTD installed in the Analysis Unit. The paramagnetic sensor is described in Part II Section 6.2.

The electronic signal processing, display and control subsystem simplifies operation of the analyzer and accurately processes the sampled data. The microprocessor controls all signal processing, input/output and display functions for the analyzer. Figure 2-1 is a block diagram for the Control Unit and Figure 2-2 is a block diagram for the Analysis Unit. These diagrams indicate the functionality of each unit and the interaction between them.

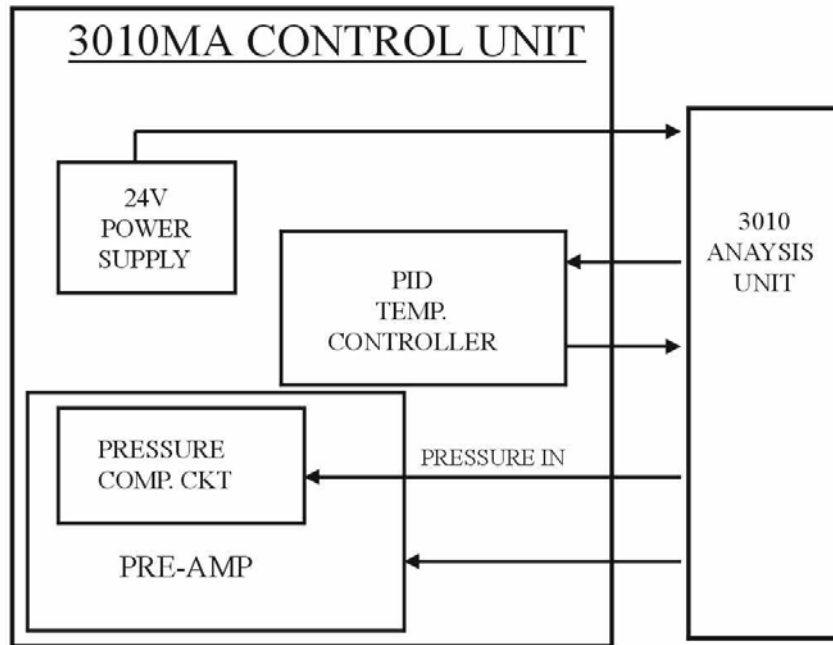

Figure 2-1: Block Diagram for Model 3010MA Control Unit

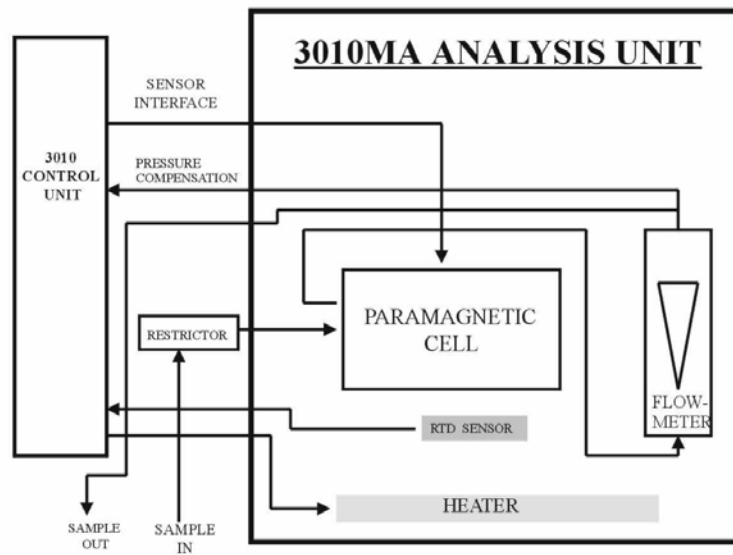

Figure 2-2: Block Diagram for Model 3010MA Analysis Unit

2.2 Electronics and Signal Processing

The Model 3010MA Paramagnetic Oxygen Purity Analyzer uses an 8031 microcontroller with 32 kB of RAM and 128 kB of ROM to control all signal processing, input/output, and display functions for the analyzer. System power is supplied from a universal power supply module designed to be compatible with any international power source (**Note: the heating system for the analysis must be set to 115V or 230V with the line voltage selector switch located on the rear Control unit**). With the exception of the paramagnetic sensor, all of the system electronics are located in the Control Unit. Figure 2-3 shows the location of the temperature controller and the main electronic PC boards.

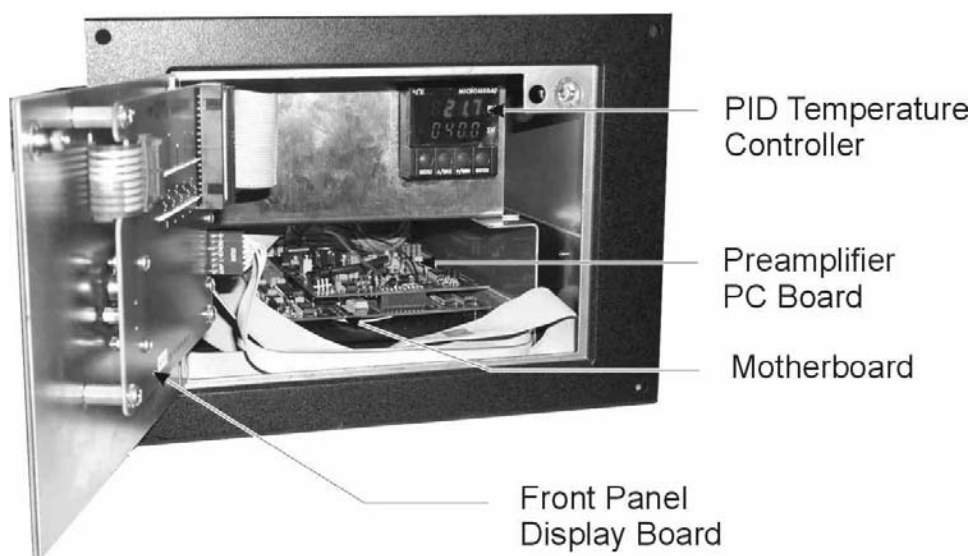

Figure 2-3: Location of Electronic Components in Control Unit

The universal power supply is located behind the temperature controller and is accessible after removing the rear panel.

The signal processing electronics including the microprocessor, analog to digital, and digital to analog converters are located on the motherboard at the bottom of the case. The preamplifier board is mounted on top of the motherboard as shown in the above figure. These boards are accessible after removing the rear panel. Figure 2-4 is a block diagram of the analyzer electronics.

When an oxygen level is present, the paramagnetic sensor in the Analysis Unit generates a voltage in the range of 0 to 1VDC. The voltage is passed to the Control Unit via the sensor cable between the Analysis Unit and the Control Unit. A voltage amplifier in the Control Unit conditions the signal and passes it to the 18-bit analog to digital (A/D) converter which is controlled by the microprocessor.

The sensor's vent pressure from the Analysis unit is received via a 1/8 inch gas connection on the rear of the control unit. The vent pressure is then routed to the pressure transducer located on the pre-amp PCB. The output from the sensor is condition by a two-stage amplifier and passed to the A/D converter.

The concentration signal, pressure signal, and the input from the control panel are processed by the microprocessor, and appropriate control signals are directed to the display, alarms and communications port.

The same digital information is also sent to a 12 bit digital to analog converter that produces the 4-20 mA dc and the 0-1VDC analog concentration signal outputs, and the analog range ID outputs.

The microprocessor monitors the power supply, and activates the system failure alarm if a malfunction is detected.

2.5 Temperature Control

For accurate analysis this instrument is temperature controlled to provide a thermally stable environment. The analyzer must be brought to thermal equilibrium prior to analyzing any sample gas. The paramagnetic sensor is sensitive to operating temperature variations. The sensor module used in the Model 3010MA includes a pre-amp and an internal temperature controller set to 55°C. The sensor module is also housed in an insulated temperature controlled oven within the Analysis Unit to improve thermal stability and isolate the system from any external temperature fluctuation. The oven temperature is maintained at a constant 40°C by the PID temperature controller located in the Control Unit (see Figure 2-3). Feedback to the temperature controller is by an RTD on the sensor mounting block. The oven is capable of providing a maximum of 80 Watts.

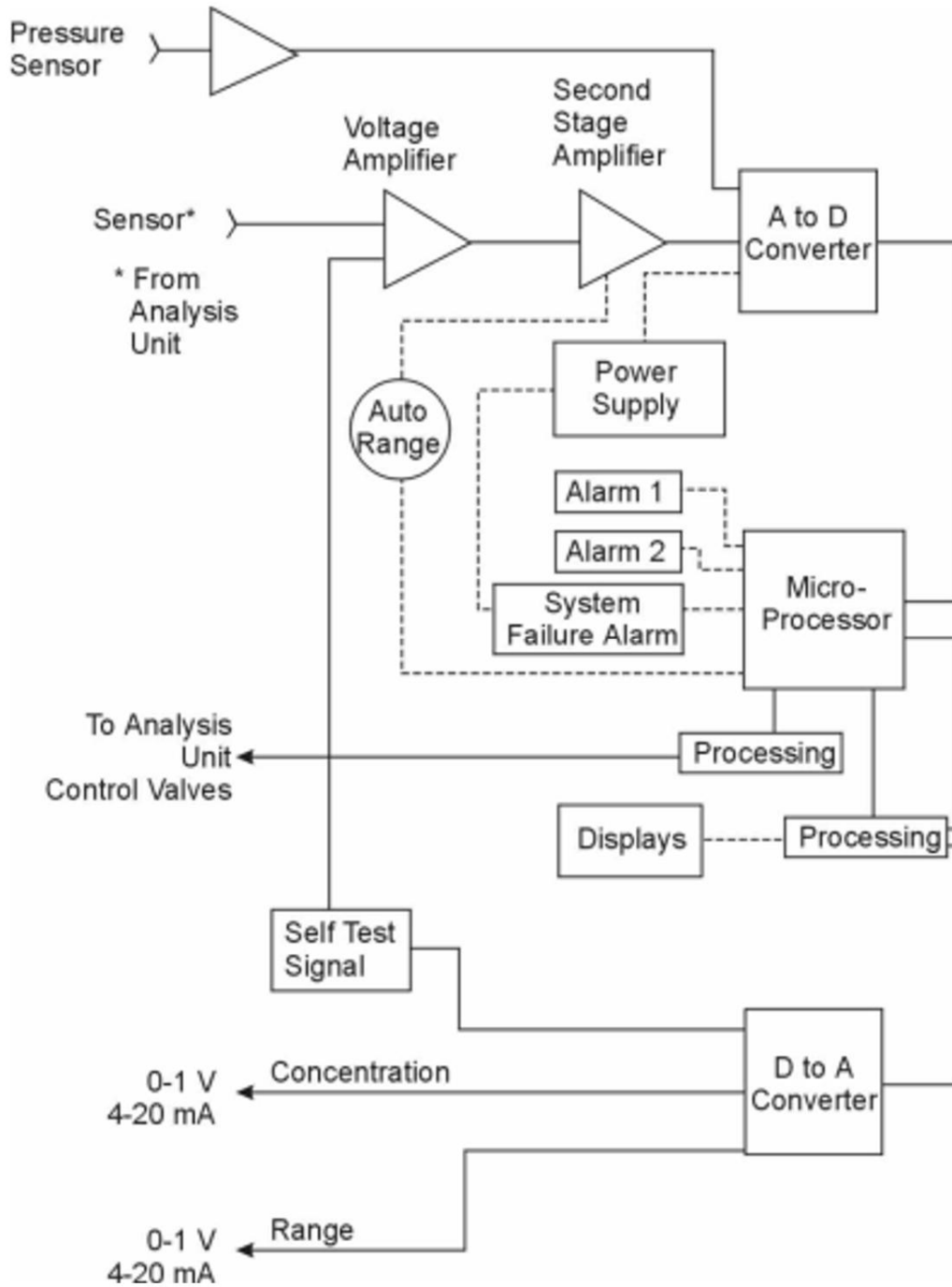

Figure 2-4: Block Diagram of the Model 3010MA Electronics

Installation

Installation of the Model 3010MA Analyzer includes:

1. Unpacking
2. Mounting
3. Gas connections
4. Electrical connections
5. Testing the system.
6. Initial Sensor Calibration

This chapter covers installation of the Control Unit. The Analysis Unit installation is covered in Part II of this manual. Procedures for the Initial Sensor Calibration is given in Part II Section 6.6.

3.1 Unpacking the Analyzer

The analyzer is shipped with all the materials you need to install and prepare the system for operation. Carefully unpack the analyzer and inspect it for damage. Immediately report any damage to the shipping agent.

3.2 Mounting the Analyzer

The Model 3010MA is for indoor use in a general purpose area. It is NOT for use in hazardous environments of any type.

The standard model is designed for flush panel mounting. There are four mounting holes—one in each corner of the rigid frame. An outline drawing D73635, is included in the Drawings section in the rear of this manual which contains a panel cutout diagram.

On special order, a 19" rack-mounting version can be provided. For rack mounting, the 3010MA Control Unit and Analysis Unit are flush-panel mounted side by side on the rack panel. Figure 3-1 is a drawing for a typical 19 inch rack mounted Model 3010 MA.

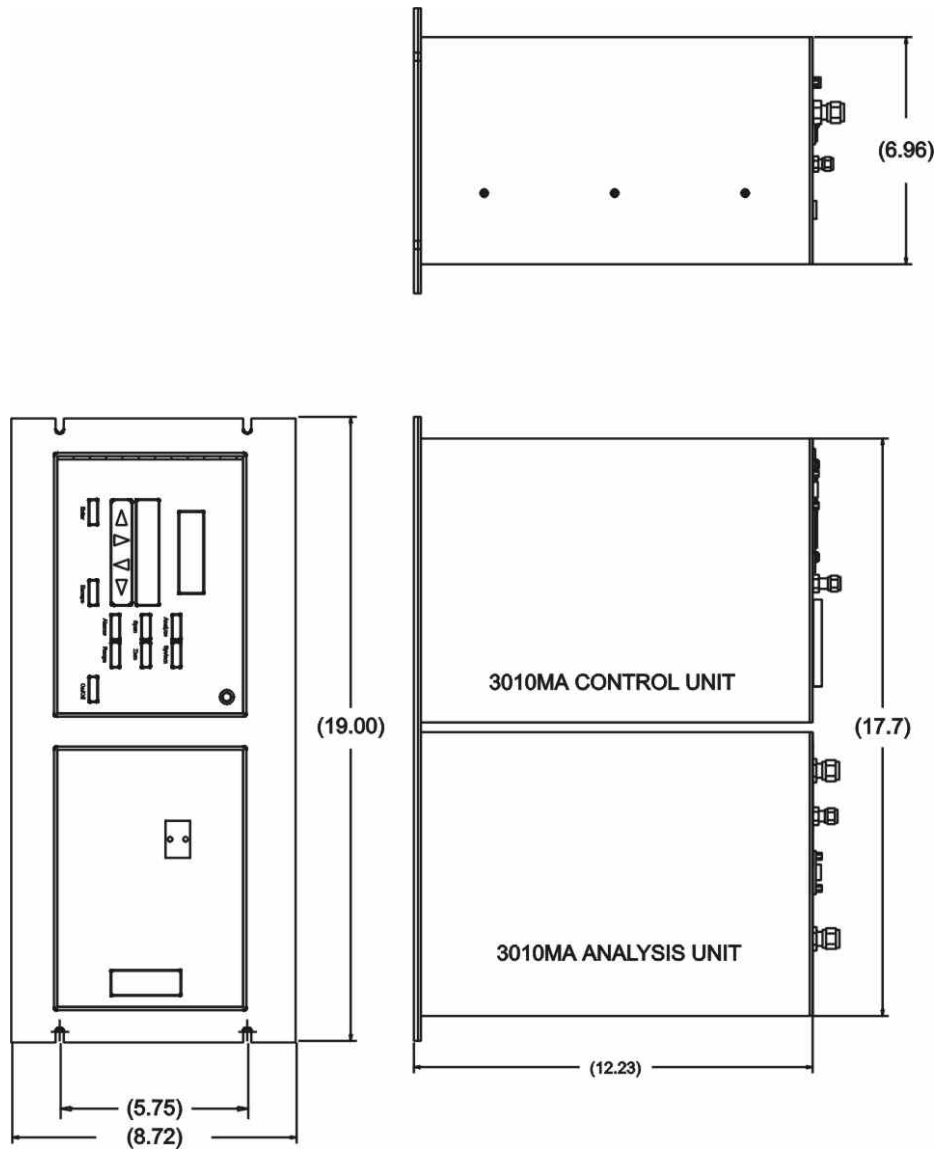

Figure 3-1: Rack Mountable Control and Analysis Units

All operator controls are mounted on the control panel which is shown in Figure 3-2. The panel is hinged on the left edge and doubles as a door to provide access to the display electronics, PCB's and temperature controller inside the instrument. The door is spring loaded and will swing open when the button in the center of the latch (upper right corner) is pressed all the way in with a narrow gauge tool (less than 0.18 inch wide), such as a small hex wrench or screwdriver. Allow clearance for the door to open in a 90-degree arc of radius 7.125 inches. See Figure 3-2.



Figure 3-2: Front Panel of the Model 3010MA

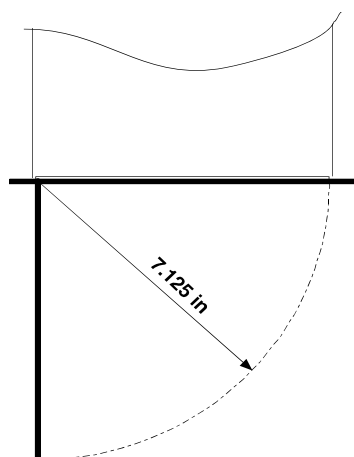

Figure 3-3: Required Front Door Clearance

3.3 Rear Panel Connections—Control Unit

Figure 3-4 shows the Model 3010MA rear panel. On this panel are connectors for interfacing with the Analysis Unit, RS-232 communication, power cord, line voltage switch, input/output connections via the 50-pin equipment interface connector and a gas inlet port for the pressure compensation circuit.

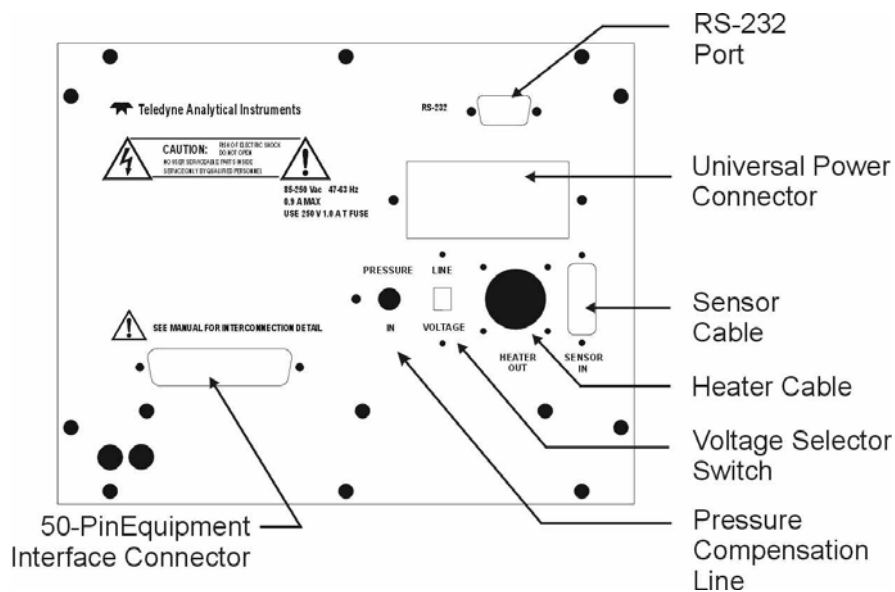

Figure 3-4: Rear Panel of the Model 3010MA Control Unit

3.3.1 Gas Connections—Control Unit

The only gas connection made to the Control Unit is the pressure compensation line extending between the Analysis unit and the Control Unit. A 1/8 inch tube fitting is installed on the rear panel for this purpose.

To connect the pressure compensation line:

1. Insert the 1/8 inch tube into the fitting and finger-tighten the nut where the tube cannot be rotated freely. Tighten the nut an additional 1/8 turn beyond finger-tight.
2. Use a wrench to hold the fitting body and keep it from turning while you tighten the nut using another wrench. When assembling new fittings for the first time: Tighten the nut 1 1/4 turns.

3.3.2 Electrical Connections—Control Unit

CAUTION: FOR SAFE CONNECTIONS, MAKE SURE THAT THERE IS NO UNINSULATED WIRE EXTENDING OUTSIDE OF THE CONNECTORS.



ALL CABLES AND CONNECTORS MUST BE IN GOOD CONDITION WITHOUT ANY BROKEN WIRES OR BENT PINS.

3.3.2.1 PRIMARY INPUT POWER

The power cord receptacle and fuse block are located in the same assembly. Insert the female plug end of the power cord into the power cord receptacle. Use only the power cord supplied with this instrument.

WARNING: POWER IS APPLIED TO THE INSTRUMENT'S CIRCUITRY WHENEVER THE INSTRUMENT IS CONNECTED TO THE POWER SOURCE. THERE IS NO ON/OFF SWITCH THAT DISCONNECTS POWER TO THE INTERNAL BOARDS, TEMPERATURE CONTROLLER AND OTHER COMPONENTS.



THE STANDBY SWITCH  ON THE FRONT PANEL IS FOR SWITCHING POWER ON OR OFF TO THE DISPLAYS AND OUTPUTS ONLY.

The analyzer requires a 90 - 130, or 200 - 240 VAC, 47/63 Hz power source. A switch on the rear panel is used to select the proper input power.

3.3.2.2 FUSE INSTALLATION

The fuse block, at the right of the power cord receptacle, includes US 3 AG and European 5-20mm size fuses. A jumper replaces the fuse in the neutral line when the fuse block is installed in the US mode. Be sure to install the fuse block in the proper mode as part of installation. (See *Fuse Replacement* in Chapter 5, *Maintenance*.)

3.3.2.3 50-PIN D-EQUIPMENT INTERFACE CONNECTOR

The large 50-pin connector on the back of the panel is the access point for all alarm relays and analog outputs. Use a 50-wire shielded cable for this interface.

Figure 3-5 shows the pin layout of the Equipment Interface connector. The arrangement is shown as seen when the viewer faces the rear panel of the analyzer. The pin numbers for each input/output function

are given where each function is described in the paragraphs below. At the end of this section is a complete pin-out description.

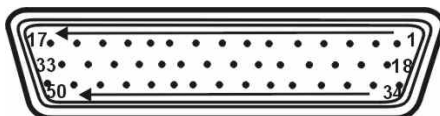

Figure 3-5: Equipment Interface Connector Pin Arrangement

Analog Outputs: There are four dc output signal pins—two pins per output. For polarity, see Table 3-1. The outputs are:

1. **0–1VDC % of Range:** Voltage rises linearly with increasing oxygen. For 95-100% range, from 0 V at 95% O₂ to 1 V at full scale 100% O₂. (Full scale is 100% O₂ for all ranges.)
2. **0–1VDC Range ID:** 0.25 V = Low Range, 0.5 V = Medium Range, 0.75 V = High Range.
3. **4–20 mA dc % Range:** (M option only) Current increases linearly with increasing oxygen, from 4 mA at 0 ppm to 20 mA at full scale. (Full scale = 100% O₂ for all ranges.)
4. **4–20 mA dc Range ID:** (This option is not included unless otherwise noted) 8 mA = Low Range, 12 mA = Medium Range, 16 mA = High Range.

Table 3-1: Analog Output Connections

Pin	Function
3	(+) Range ID, 4-20 mA, floating (special option)
4	(-) Range ID, 4-20 mA, floating (special option)
5	(+) % Range, 4-20 mA, floating
6	(-) % Range, 4-20 mA, floating
8	(+) Range ID, 0-1VDC
23	(-) Range ID, 0-1VDC, negative ground
24	(+) % Range, 0-1VDC
7	(-) % Range, 0-1VDC, negative ground

Alarm Relays: There are nine pins dedicated to the internal alarm relay contacts. Each set of three pins provides one set of Form C relay contacts. Each relay has both normally open and normally closed

contact connections. The contact connections are shown in Table 3-2. They are capable of switching up to 3 amperes at 250 V ac into a resistive load.

Threshold Alarm 1 can be configured as:

- High (actuates when concentration is above threshold) or low (actuates when concentration is below threshold).
- Failsafe or Non-failsafe.
- Latching or Non-latching.
- Out (defeated).

Threshold Alarm 2 can be configured as :

- High (actuates when concentration is above threshold), or Low (actuates when concentration is below threshold).
- Failsafe or non-failsafe
- Latching or non-latching
- Out (defeated).

System Alarm: Actuates when DC power supplied to circuits is unacceptable in one or more parameters. Permanently configured as failsafe and latching. Cannot be defeated. Actuates if self test fails.

(Reset by pressing Standby button  to shut-down the analyzer. Then press  again and any other button EXCEPT System to resume.

Further detail can be found in Chapter 4, Section 4-5.

Table 3-2: Alarm Relay Contact Pins

Pin	Contact
45	Threshold Alarm 1, normally closed contact
28	Threshold Alarm 1, moving contact
46	Threshold Alarm 1, normally open contact
42	Threshold Alarm 2, normally closed contact
44	Threshold Alarm 2, moving contact
43	Threshold Alarm 2, normally open contact

- 36 System Alarm, normally closed contact
- 20 System Alarm, moving contact
- 37 System Alarm, normally open contact

Digital Remote Cal Inputs: Accept 0 V (off) or 24 V (on) inputs for remote control of calibration. (See *Remote Calibration Protocol* below.) See Table 3-3 for pin connections.

Zero: Floating input. 5 to 24 V input across the + and – pins puts the analyzer into the *Zero* mode. Either side may be grounded at the source of the signal. 0 to 1 volt across the terminals allows *Zero* mode to terminate when done. A synchronous signal must open and close the external zero valve appropriately.

Span: Floating input. 5 to 24 V input across the + and – pins puts the analyzer into the *Span* mode. Either side may be grounded at the source of the signal. 0 to 1 volt across the terminals allows *Span* mode to terminate when done. A synchronous signal must open and close external span valve appropriately. See Figure 3-5 *Remote Probe Connector*. (The –C option internal valves operate automatically.)

Cal Contact: This relay contact is closed while analyzer is spanning and/or zeroing. (See *Remote Calibration Protocol* below.)

Table 3-3: *Remote Calibration Connections*

Pin	Function
9	+ Remote Zero
11	– Remote Zero
10	+ Remote Span
12	– Remote Span
40	Cal Contact
41	Cal Contact

Remote Calibration Protocol: To properly time the Digital Remote Cal Inputs to the Model 3010MA Analyzer, the customer's controller must monitor the Cal Relay Contact.

When the contact is OPEN, the analyzer is analyzing, the Remote Cal Inputs are being polled, and a zero or span command can be sent.

When the contact is CLOSED, the analyzer is already calibrating. It will ignore your request to calibrate, and it will not remember that request.

Once a zero or span command is sent, and acknowledged (contact closes), release it. If the command is continued until after the zero or span is complete, the calibration will repeat and the Cal Relay Contact (CRC) will close again.

For example:

1. Test the CRC. When the CRC is open, Send a zero command until the CRC closes (The CRC will quickly close.)
2. When the CRC closes, remove the zero command.
3. When CRC opens again, send a span command until the CRC closes. (The CRC will quickly close.)
4. When the CRC closes, remove the span command.
5. When CRC opens again, zero and span are done, and the sample is being analyzed.

NOTE: The Remote Valve connections (described below) provides signals to ensure that the zero and span gas valves will be controlled synchronously.

Range ID Relays: Three dedicated Range ID relay contacts. The first three ranges are assigned to relays in ascending order—Low range is assigned to Range 1 ID, Medium range is assigned to Range 2 ID, and High range is assigned to Range 3 ID. Table 3-4 lists the pin connections.

Table 3-4: Range ID Relay Connections

Pin	Function
21	Range 1 ID Contact
38	Range 1 ID Contact
22	Range 2 ID Contact

39	Range 2 ID Contact
19	Range 3 ID Contact
18	Range 3 ID Contact
34	Not used in 3010MA
35	Not used in 3010MA

Network I/O: A serial digital input/output for local network protocol. At this printing, this port is not yet functional. It is to be used for future options to the instrument. Pins 13 (+) and 29 (-).

Remote Valve Connections: The 3010MA is not equipped with remote valves for controlling sample or calibration gases however these valves can be added by the user. The instrument is capable of driving up to 4 remote solenoid valves as detailed below. The remote valve connections are used as a method for directly controlling external sample/zero/span gas valves. See Figure 3-6.

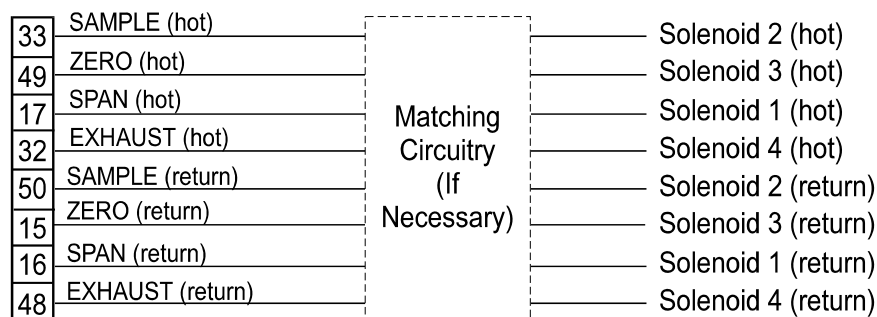

Figure 3-6: Remote Valve Connections

The voltage from these outputs is nominally 0 V for the OFF and 15VDC for the ON conditions. The maximum combined current that can be pulled from these output lines is 100 mA. (If two lines are ON at the same time, each must be limited to 50 mA, etc.) If more current and/or a different voltage is required, use a relay, power amplifier, or other matching circuitry to provide the actual driving current.

In addition, each individual line has a series FET with a nominal ON resistance of 5 ohms (9 ohms worst case). This can limit the obtainable voltage, depending on the load impedance applied. See Figure 3-7.

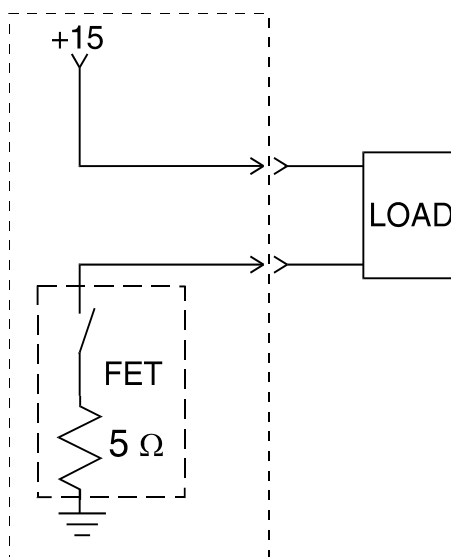

Figure 3-7: FET Series Resistance

Below is a table of the complete pin-out connections of the 50-pin equipment interface connector.

Table 3-5: 50-Pin Equipment Interface Connector

Pin	Function	Pin	Function
1		26	
2		27	
3	(+) Range ID, 4-20 mA floating *	28	Threshold Alarm 1 Mov. Contact
4	(-) Range ID, 4-20 mA floating *	29	
5	(+) %Range, 4-20 mA floating	30	
6	(-) %Range, 4-20 mA floating	31	
7	(-) %Range, 0-1VDC neg gnd	32	Remote EXHAUST valve (hot)
8	(+) Range ID, 0-1VDC	33	Remote SAMPLE valve (hot)
9	(+) Remote Zero	34	
10	(+) Remote Span	35	
11	(-) Remote Zero	36	System Alarm, NC Contact

12	(-) Remote Span	37	System Alarm, NO Contact
13		38	Range 1 ID Contact
14		39	Range 2 ID Contact
15	Remote ZERO valve (return)	40	Cal Contact
16	Remote SPAN valve (return)	41	Cal Contact
17	Remote SPAN valve (hot)	42	
18	Range 3 ID Contact	43	
19	Range 3 ID Contact	44	
20	System Alarm Moving Contact	45	
21	Range 1 ID Contact	46	
22	Range 2 ID Contact	47	
23	(-) Range ID, 0-1VDC neg gnd	48	Remote EXHAUST valve (return)
24	(+) % Range, 0-1VDC	49	Remote ZERO valve (hot)
25		50	Remote SAMPLE valve (return)

* Available by special option only.

3.3.2.4 RS-232 PORT

The digital signal output is a standard RS-232 serial communications port used to connect the analyzer to a computer, terminal, or other digital device. It requires a standard 9-pin D connector.

The data is status information, in digital form, updated every two seconds. Status is reported in the following order:

- The concentration in percent
- The range in use (HI, MED, LO)
- The span of the range (95-100%, etc)
- Which alarms—if any—are disabled (AL-x DISABLED)
- Which alarms—if any—are tripped (AL-x ON).

Each status output is followed by a carriage return and line feed.

Four input functions using RS-232 have been implemented to date. They are described in Table 3-1.

Table 3-6: Commands via RS-232 Input

Command	Description
as <enter>	Immediately starts an autospan
az <enter>	Immediately starts an autozero.
co <enter>	Reports "Sensor Output" (voltage output of the sensor itself) inVDC For example— Raw Sensor Output: 1.000 volts
st <enter>	Toggling input. Stops/Starts any status message output from the RS-232, until st <enter> is sent again.

The RS-232 protocol allows some flexibility in its implementation. Table 3-2 lists certain RS-232 values that are required by the 3010MA implementation.

Table 3-7: Required RS-232 Options

Parameter	Setting
Baud	2400*
Byte	8 bits
Parity	None
Stop Bits	1
Message Interval	2 seconds

*2400 is the standard baud rate, but if unit is to be coupled to TAI's Valve Box, the baud rate required is 9600 and set at the factory by customer order.

3.4 Installing the Analysis Unit

Installing the Analysis unit involves:

- Mounting the Analysis Unit
- Making gas connections to rear panel
- Making electrical connections to rear panel

The Analysis Unit is installed adjacent to the Control Unit usually on the same panel. Refer to Section 3.2 for mounting instructions. An outline drawing D73635, is included in the Drawings section in the rear of this manual which contains a panel cutout diagram.

3.5 Rear Panel Connections—Analysis Unit

The Rear Panel of the Analysis Unit is shown in Figure 3-8. The following connections to the Analysis Unit are made at the rear panel:

- Gas connections
 - Sample In
 - Sample Vent
 - Pressure Vent (pressure compensation line to Control Unit)
- Electrical
 - Signal Output
 - Heater Power



Figure 3-8: Analysis Unit Rear Panel

3.5.1 Gas Connections—Analysis Unit

When making gas connections to the fittings on the rear panel of the Analysis Unit:

1. Insert the 1/4 or 1/8 inch tube into the fitting and finger-tighten the nut where the tube cannot be rotated freely. Tighten the nut an additional 1/8 turn beyond finger-tight.
2. When assembling new fittings for the first time: Use a wrench to hold the fitting body and keep it from turning while you tighten the nut using another wrench. Tighten the nut 1 ¼ turns.

NOTE: The analyzer requires the use of a flow limiting device installed in the sample in line to prevent damage to the sensor. The analyzer is shipped with an appropriate flow restrictor which should be installed in the sample line upstream of the Analysis Unit.

It is also recommended that a 50 micron filter be installed in the sample line upstream from the restrictor to remove particulate matter that could otherwise clog the narrow passageways in the restrictor or sensor. The sample system is described in Part II Section 6.4.

NOTE: If a bypass loop is used to increase the system response, this loop must be external to the analyzer.

1. Install flow restrictor or valve
2. Connect the 1/4 inch Sample In line
2. Connect the 1/4 inch Sample Vent line
3. Connect the 1/8 inch Pressure Vent line from the Control Unit

The Analysis Unit is now installed and ready for leak checking. Refer to Section 6.5 for leak checking procedures.

3.6 Testing the System

Before plugging the instrument into the power source:

1. Install the Analysis Unit. Refer to Section 3.4 for information on installing the Analysis Unit.
2. Check the integrity and accuracy of the gas connections. Make sure there are no leaks.
3. Check the integrity and accuracy of the electrical connections. Make sure there are no exposed conductors.

4. Check that sample flow rate is between 300 and 1000 SCCM.

CAUTION: FLOW RATES ABOVE 1000 SCCM CAN DAMAGE THE SENSOR!



5. Power up the system, and test it by repeating the Self-Diagnostic Test as described in Chapter 4, Section 4.3.5

Note: To achieve the stated accuracy, this unit must be allowed to reach thermal equilibrium and the sensor must be purged to remove all traces of water vapor.

6. Purge the sensor for a minimum of 24 hours to remove any residual water vapor or contaminants.

Note: Purging can be accomplished with sample gas if the gas is dry. If in doubt, use an inert dry gas connected to the sample in port for purging.

Following the Self-diagnostic test and sensor purge, if the instrument is being put into service for the first time or there has been a significant change in the vent line pressure, the instrument will require an initial sensor calibration. This procedure is described in Part II Section 6.6.

If this is not the first time powered up and an initial sensor calibration is not required, read the entire Section 4 to familiarize yourself with the operating interface of the instrument, then proceed to Section 4.4 to calibrate the instrument.

Operation

4.1 Introduction

Once the analyzer has been installed, it can be configured for your application. To do this you will:

1. Set system parameters:
2. Establish a security password, if desired, requiring the operator to log in.
3. Establish and start an automatic calibration cycle, if desired.
4. Calibrate the instrument.
5. Accept the default configuration or define the three user selectable analysis ranges. Then choose autoranging or select a fixed range of analysis, as required.
6. Set alarm setpoints, and modes of alarm operation (latching, failsafe, etc).

Before you configure your 3010MA these default values are in effect:

Ranges: LO = 0-100 %, MED = 95-100 %, HI = 98-100 %

Auto Ranging: ON

Alarm Relays: Defeated, 99%, HI, Not failsafe, Not latching

Zero: Auto, every 0 days at 0 hours, at 0% O₂

Span: Auto, at 100% O₂ every 0 days at 0 hours

If you choose not to use password protection, the default password is automatically displayed on the password screen when you start up, and you simply press *Enter* for access to all functions of the analyzer.

4.2 Using the Data Entry and Function Buttons

Data Entry Buttons: The <> arrow buttons select options from the menu currently displayed on the VFD screen. The selected option will blink.

When the selected option includes a modifiable item, the $\Delta\nabla$ arrow buttons can be used to increment or decrement that modifiable item.

The *Enter* button is used to accept any new entries on the VFD screen. The *Escape* button is used to abort any new entries on the VFD screen that are not yet accepted by use of the *Enter* button.

Figure 4-1 shows the hierarchy of functions available to the operator via the function buttons.

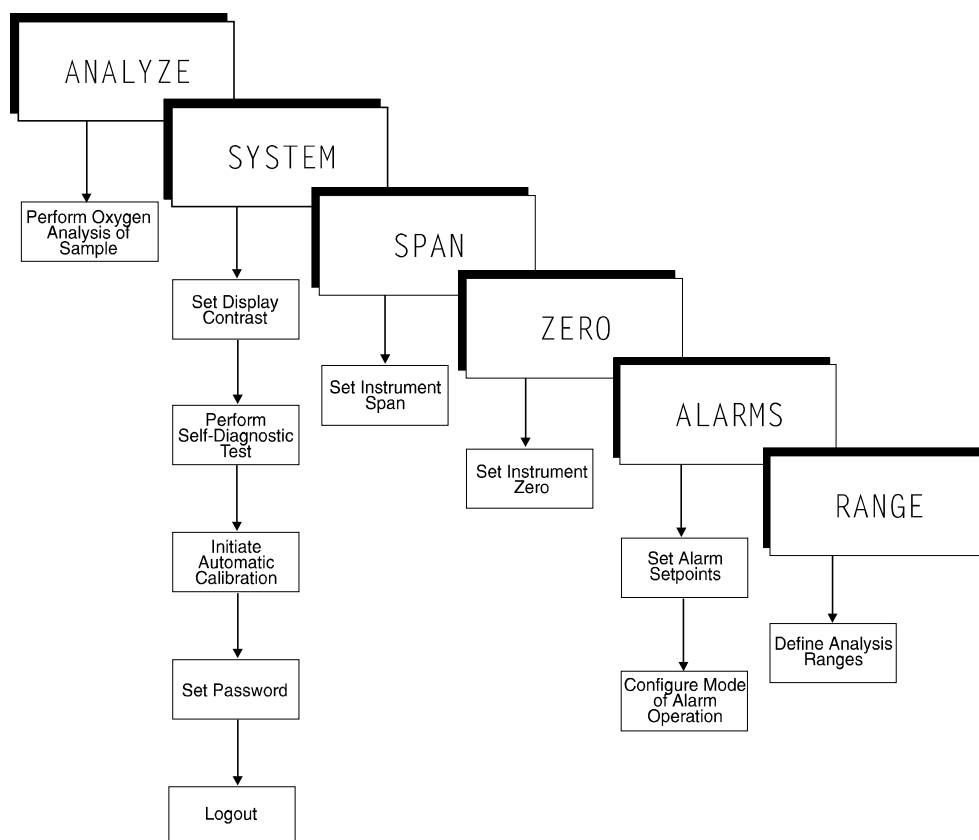

Figure 4-1: Hierarchy of Functions Available on the Model 3010MA

The six function buttons on the analyzer are:

- **Analyze.** This is the normal operating mode. The analyzer monitors the oxygen content of the sample, displays the percent of oxygen, and warns of any alarm conditions.
- **System.** The system function consists of six subfunctions that regulate the internal operations of the analyzer:
 - Set LCD screen contrast

- Setup Auto-Cal
- Assign Password
- Initiate Self-Test
- Check software version
- View sensor output
- Log out.
- *Zero*. Used to set up a zero calibration.
- *Span*. Used to set up a span calibration.
- *Alarms*. Used to set the alarm setpoints and determine whether each alarm will be active or defeated, HI or LO acting, latching, and/or failsafe.
- *Range*. Used to set up three analysis ranges that can be switched automatically with auto-ranging or used as individual fixed ranges.

Any function can be selected at any time by pressing the appropriate button (unless password restrictions apply). The order as presented in this manual is appropriate for an initial setup.

Each of these functions is described in greater detail in the following procedures. The VFD screen text that accompanies each operation is reproduced, at the appropriate point in the procedure, in a **Monospaced** type style. Pushbutton names are printed in *Oblique* type.

4.3 The System Function

The subfunctions of the *System* function are described below. Specific procedures for their use follow the descriptions:

- **Auto-Cal:** Used to define an automatic calibration sequence and/or start an Auto-Cal.
- **PSWD:** Security can be established by choosing a 5 digit password (PSWD) from the standard ASCII character set. (See *Installing or Changing a Password*, below, for a table of ASCII characters available.) Once a unique password is assigned and activated, the operator **MUST** enter the **UNIQUE** password to gain access to set-up functions which alter the instrument's operation, such as setting the instrument span or zero setting, adjusting the alarm setpoints, or defining analysis ranges.

After a password is assigned, the operator must **log out** to activate it. Until then, anyone can continue to operate the instrument without entering the new password.

Only one password can be defined. Before a unique password is assigned, the system assigns TETAI by default. This allows access to anyone. After a unique password is assigned, to defeat the security, the password must be changed back to TETAI.

- **Logout:** Logging out prevents an unauthorized tampering with analyzer settings.
- **More:** Select and enter **More** to get a new screen with additional subfunctions listed. Within this category is an option to display sensor output.
- **Self-Test:** The instrument performs a self-diagnostic test to check the integrity of the power supply, output boards and amplifiers.
- **Version:** Displays Manufacturer, Model, and Software Version of instrument.

4.3.1 Setting the Display

NOTE: Contrast function is disabled.

If you cannot read anything on the display after first powering up:

1. Observe LED readout.
 - a. The LED meter should read all eights and periods.
 - b. If LED meter displays anything else, go to step 2.
2. Press **Standby** button twice to turn Analyzer OFF and ON again. LED meter should now read all eights and periods.

4.3.2 Setting up an Auto-Cal

When proper automatic valving is connected (see Part II Chapter 3, installation), the Analyzer can cycle itself through a sequence of steps that automatically zero and span the instrument.

NOTE: If you require highly accurate Auto-Cal timing, use external Auto-Cal control where possible. The internal clock in the Model 3010MA is accurate to 2-3%. Accordingly, internally scheduled calibrations can vary 2-3% per day.



To setup an Auto-Cal cycle:

Choose *System* from the Function buttons. The VFD will display five subfunctions.

**Contrast Auto-Cal
PSWD Logout More**

Use <> arrows to blink Auto-Cal, and press *Enter*. A new screen for Span/Zero set appears.

**Span OFF Nxt: 0d 0h
Zero OFF Nxt: 0d 0h**

Press <> arrows to blink Span (or Zero), then press *Enter* again. (*You won't be able to set OFF to ON if a zero interval is entered.*) A Span Every ... (or Zero Every ...) screen appears.

**Span Every 0 d
Start 0 h from now**

Use $\Delta\nabla$ arrows to set an interval value, then use <> arrows to move to the start-time value. Use $\Delta\nabla$ arrows to set a start-time value.

To turn ON the Span and/or Zero cycles (to activate Auto-Cal): Press *System* again, choose Auto-Cal, and press *Enter* again. When the Span/Zero screen appears, use the <> arrows to blink the Span (or Zero) OFF / ON field. Use $\Delta\nabla$ arrows to set the OFF / ON field to ON. You can now turn these fields ON because there is a nonzero span interval defined.

4.3.3 Password Protection

If a password is assigned, then setting the following system parameters can be done only after the password is entered: **span** and **zero** settings, **alarm** setpoints, analysis **range** definitions, switching between **autoranging** and manual override, setting up an **auto-cal**, and assigning a new **password**. However, the instrument can still be used for analysis or for initiating a self-test without entering the password.

If you have decided not to employ password security, use the default password TETAI. This password will be displayed automatically by the microprocessor. The operator just presses the Enter key to be allowed total access to the instrument's features.

NOTE: If you use password security, it is advisable to keep a copy of the password in a separate, safe location.

4.3.3.1 ENTERING THE PASSWORD

To install a new password or change a previously installed password, you must key in and *ENTER* the old password first. If the default password is in effect, pressing the *ENTER* button will enter the default TETAI password for you.

Press *System* to enter the *System* mode.

**Contrast Auto-Cal
PSWD Logout More**

Use the <> arrow keys to scroll the blinking over to PSWD, and press *Enter* to select the password function. Either the default TETAI password or AAAAA place holders for an existing password will appear on screen depending on whether or not a password has been previously installed.

**T E T A I
Enter PWD**

or

**A A A A A
Enter PWD**

The screen prompts you to enter the current password. If you are not using password protection, press *Enter* to accept TETAI as the default password. If a password has been previously installed, enter the password using the <> arrow keys to scroll back and forth between letters, and the $\Delta\nabla$ arrow keys to change the letters to the proper password. Press *Enter* to enter the password.

If the password is accepted, the screen will indicate that the password restrictions have been removed and you have clearance to proceed.

**PSWD Restrictions
Removed**

In a few seconds, you will be given the opportunity to change this password or keep it and go on.

**Change Password?
<ENT>=Yes <ESC>=No**

Press *Escape* to move on, or proceed as in *Changing the Password*, below.

4.3.3.2 INSTALLING OR CHANGING THE PASSWORD

If you want to install a password, or change an existing password, proceed as above in *Entering the Password*. When you are given the opportunity to change the password:

Change Password?
 <ENT>=Yes <ESC>=No

Press *Enter* to change the password (either the default TETAI or the previously assigned password), or press *Escape* to keep the existing password and move on.

If you chose *Enter* to change the password, the password assignment screen appears.

T E T A I
 <ENT> To Proceed

or

A A A A A
 <ENT> To Proceed

Enter the password using the <> arrow keys to move back and forth between the existing password letters, and the Δ ∇ arrow keys to change the letters to the new password. The full set of 94 characters available for password use are shown in the table below.

Characters Available for Password Definition:

A	B	C	D	E	F	G	H	I	J
K	L	M	N	O	P	Q	R	S	T
U	V	W	X	Y	Z	[¥]	^
_	`	a	b	c	d	e	f	g	h
i	j	k	l	m	n	o	p	q	r
s	t	u	v	w	x	y	z	{	
}	→	!	"	#	\$	%	&	'	(
)	*	+	'	-	.	/	0	1	2
3	4	5	6	7	8	9	:	;	<
=	>	?	@						

When you have finished typing the new password, press *Enter*. A verification screen appears. The screen will prompt you to retype your password for verification.

A A A A A
Retype PWD To Verify

Wait a moment for the entry screen. You will be given clearance to proceed.

A A A A A
<ENT> TO Proceed

Use the arrow keys to retype your password and press *Enter* when finished. Your password will be stored in the microprocessor and the system will immediately switch to the *Analyze* screen, and you now have access to all instrument functions.

If all alarms are defeated, the *Analyze* screen appears as:

95.00 % Anlz
Range: 95 - 100

If an alarm is tripped, the second line will change to show which alarm it is:

95.00 % Anlz
AL-1

NOTE: If you log off the system using the logout function in the system menu, you will now be required to re-enter the password to gain access to Span, Zero, Alarm, and Range functions.

4.3.4 Logout

The Logout function provides a convenient means of leaving the analyzer in a password protected mode without having to shut the instrument off. By entering Logout, you effectively log off the instrument leaving the system protected against use until the password is reentered. To log out, press the *System* button to enter the *System* function.

Contrast Auto-Cal
PSWD Logout More

Use the < > arrow keys to position the blinking over the Logout function, and press *Enter* to Log out. The screen will display the message:

Protected Until
Password Reentered

4.3.5 System Self-Diagnostic Test

The Model 3010MA has a built-in self-diagnostic testing routine. Pre-programmed signals are sent through the power supply, output board and sensor circuit. The return signal is analyzed, and at the end of the test the status of each function is displayed on the screen, either as OK or as a number between 1 and 3. (See *System Self Diagnostic Test* in Chapter 5 for number code.)

The self diagnostics are run automatically by the analyzer whenever the instrument is turned on, but the test can also be run by the operator at will. To initiate a self diagnostic test during operation:

Press the *System* button to start the *System* function.

```
Contrast Auto-Cal
PSWD Logout More
```

Use the < > arrow keys to blink More, then press *Enter*.

```
Version Self-Test
Sensor Output: ###
```

Use the < > arrow keys again to move the blinking to the Self-Test function. The screen will follow the running of the diagnostic.

```
RUNNING DIAGNOSTIC
Testing Preamp - 83
```

During preamp testing there is a countdown in the lower right corner of the screen. When the testing is complete, the results are displayed.

```
Power: OK   Analog: OK
Preamp: 0
```

The module is functioning properly if it is followed by OK. A number indicates a problem in a specific area of the instrument. Refer to Chapter 5 *Maintenance and Troubleshooting* and Table 5-1 for number-code information. The results screen alternates for a time with:

```
Press Any Key
To Continue...
```

Then the analyzer returns to the initial System screen.

4.3.6 Version Screen

Move the < > arrow key to More and press *Enter*. With Version blinking, press *Enter*. The screen displays the manufacturer, model, and software version information.

4.3.7 Display Sensor Output

The raw output of the sensor can be displayed from the Sensor Output screen. This is useful during initial sensor calibration where the sensor output is adjusted to correspond to zero and span values at ambient (or operating) vent pressure. See Section 6.

To view the sensor output, press the *System* button to start the *System* function.

```
Contrast Auto-Cal
PSWD Logout More
```

Use the < > arrow keys to blink More, then press *Enter*.

```
Version Self-Test
###.## #####
```

The Output of the sensor in volts is the first number shown on the second line. The second number is a raw output of the pressure sensor in A to D counts.

4.4 The Zero and Span Functions

The analyzer can be calibrated using a background gas without Oxygen as zero and Oxygen for span gas.

NOTE: After installation, an initial sensor calibration may be required before the instrument is calibrated in order for the pressure compensation circuitry to work properly. See Section 6.6.

Connect the calibration gases to the analyzer according to the instructions given in Section 3.4.1, *Gas Connections*, and in Part II of this manual observing all the prescribed precautions.



Shut off the gas pressure before connecting it to the analyzer, and be sure to limit the pressure to 15 psig or less when turning it back on.

Readjust the gas pressure into the analyzer until the flowrate (as read on the Analysis Unit flowmeter) settles between 300-1000 SCCM, preferably 500 SCCM.

If you are using password protection, you will need to enter your password to gain access to either of these functions. Follow the instructions in section 4.3.3 to enter your password. Once you have gained clearance to proceed, you can enter the *Zero* or *Span* function.

The procedures that follow can be used for either the zero or span functions. Only the span function is described. Analyzer should always be zeroed first and then spanned for accurate results.

NOTE: Make sure you choose the right function for the calibration gas used, i.e. span gas and span function NOT span gas and zero function!

4.4.1 Span Cal

The *Span* button on the front panel is used to span calibrate the analyzer. Span calibration can be performed using the **automatic** mode, where an internal algorithm compares consecutive readings from the sensor to determine when the output matches the span gas concentration. Span calibration can also be performed **manual** mode, where the operator determines when the span concentration reading is acceptable and then manually exits the function.

4.4.1.1 AUTO MODE SPANNING

Press *Span* to enter the span function. The screen that appears allows you to select whether the span calibration is to be performed automatically or manually. Use the $\Delta\nabla$ arrow keys to toggle between AUTO and MAN span settling. Stop when AUTO appears, blinking, on the display.

Span: Settling: AUTO
<ENT> For Next

Press *Enter* to move to the next screen.

Span Val: 100.00
<ENT>Span <UP>Mod #

Use the $\Delta\nabla$ arrow keys to enter the oxygen-concentration mode. Use the < > arrow keys to blink the digit you are going to modify. Use the $\Delta\nabla$ arrow keys again to change the value of the selected digit. When you have finished typing in the concentration of the span gas you are using, press *Enter* to begin the Span calibration.

% Span
Slope=#### ppm/s

The beginning span value is shown in the upper left corner of the display. As the span reading settles, the screen displays and updates information on Slope. Spanning automatically ends when the slope is less than 1/50 of the displayed value of the oxygen concentration (in ppm) for three minutes. Then the instrument automatically returns to the analyze mode.

4.4.1.2 MANUAL MODE SPANNING

Press *Span* to start the *Span* function. The screen that appears allows you to select whether the span calibration is to be performed automatically or manually.

Span: Settling:MAN
<ENT> For Next

Use the $\Delta\nabla$ keys to toggle between AUTO and MAN span settling. Stop when MAN appears, blinking, on the display. Press *Enter* to move to the next screen.

Span Val: 100.00
<ENT>Span <UP>Mod #

Press Δ (<UP>) to permit modification (Mod #) of span value.

Use the arrow keys to enter the oxygen concentration of the span gas you are using. The < > arrows chose the digit, and the $\Delta\nabla$ arrows choose the value of the digit.

Press *Enter* to enter the span value into the system and begin the span calibration.

Once the span has begun, the microprocessor samples the output at a predetermined rate. It calculates the difference between successive samplings and displays this difference as **Slope** on the screen. It takes several seconds for the first **Slope** value to display. **Slope** indicates rate of change of the Span reading. It is a sensitive indicator of stability.

% Span
Slope=#### ppm/s

When the Span value displayed on the screen is sufficiently stable, press *Enter*. (Generally, when the Span reading changes by 1% or less of the full scale of the range being calibrated for a period of five minutes it is sufficiently stable.) Once *Enter* is pressed, the Span reading changes to the correct value. The instrument then automatically enters the *Analyze* function.

4.5 The Alarms Function

The Model 3010MA is equipped with 2 fully adjustable concentration alarms and a system failure alarm. Each alarm has a relay with a set of form "C" contacts rated for 3 amperes resistive load at 250 V ac. See Figure in Chapter 3, *Installation* and/or the Interconnection Diagram included at the back of this manual for relay terminal connections.

The system failure alarm has a fixed configuration described in chapter 3 *Installation*.

The concentration alarms can be configured from the front panel as either *high* or *low* alarms by the operator. The alarm modes can be set as *latching* or *non-latching*, and either *failsafe* or *non-failsafe*, or, they can be *defeated* altogether. The setpoints for the alarms are also established using this function.

Decide how your alarms should be configured. The choice will depend upon your process. Consider the following four points:

1. Which if any of the alarms are to be high alarms and which if any are to be low alarms?

Setting an alarm as HIGH triggers the alarm when the oxygen concentration rises **above** the setpoint. Setting an alarm as LOW triggers the alarm when the oxygen concentration falls **below** the setpoint.

Decide whether you want the alarms to be set as:

- Both high (high and high-high) alarms, or
- One high and one low alarm, or
- Both low (low and low-low) alarms.

2. Are either or both of the alarms to be configured as failsafe?

In failsafe mode, the alarm relay de-energizes in an alarm condition. For non-failsafe operation, the relay is energized in an alarm condition. You can set either or both of the concentration alarms to operate in failsafe or non-failsafe mode.

3. Are either of the alarms to be latching?



In latching mode, once the alarm or alarms trigger, they will remain in the alarm mode even if process conditions revert to non-alarm conditions. This mode requires an alarm to be recognized before it can be reset. In the non-latching mode, the alarm status will terminate when process conditions revert to non-alarm conditions.

4. Are either of the alarms to be defeated?

The defeat alarm mode is incorporated into the alarm circuit so that maintenance can be performed under conditions which would normally activate the alarms.

The defeat function can also be used to reset a latched alarm. (See procedures, below.)

If you are using password protection, you will need to enter your password to access the alarm functions. Follow the instructions in Section 4.3.3 to enter your password. Once you have clearance to proceed, enter the *Alarm* function.

Press the *Alarm* button on the front panel to enter the *Alarm* function. Make sure that AL-1 is blinking.

```
AL-1    AL-2
Choose Alarm
```

Set up alarm 1 by moving the blinking over to AL-1 using the < > arrow keys. Then press *Enter* to move to the next screen.

```
AL-1 98.00 %    HI
Dft-N Fs-N Ltch-N
```

Five parameters can be changed on this screen:

- Value of the alarm setpoint, AL-1 ##### % (oxygen)
- Out-of-range direction, HI or LO
- Defeated? Dft-Y/N (Yes/No)
- Failsafe? Fs-Y/N (Yes/No)
- Latching? Ltch-Y/N (Yes/No).

To define the setpoint, use the < > arrow keys to move the blinking over to AL-1 #####. Then use the $\Delta \nabla$ arrow keys to change the number. Holding down the key speeds up the incrementing or decrementing. (Remember, the setpoint units are percent-of-oxygen.)

To set the other parameters use the < > arrow keys to move the blinking over to the desired parameter. Then use the Δ ∇ arrow keys to change the parameter.

Once the parameters for alarm 1 have been set, press *Alarms* again, and repeat this procedure for alarm 2 (AL-2).

To reset a latched alarm, go to Dft- and then press either Δ two times or ∇ two times. (Toggle it to Y and then back to N.)

–or –

Go to Ltch- and then press either Δ two times or ∇ two times. (Toggle it to N and back to Y.)

4.6 The *Range* Function

The Range function allows the operator to program up to three concentration ranges from 0 to 100% oxygen in increments of 1%. Only the lower value of the range is adjustable. The upper range value for all three ranges on the Oxygen Purity Analyzer is non-adjustable and fixed at 100%. The lower value can be adjusted anywhere from 99% to 0%. Once set, the ranges will correlate with the DC analog outputs. If no custom ranges are defined by the user, the instrument defaults to:

Low = 0–100 %
Med = 95–100 %
High = 98–100 %.

The ranges must be set for increasing concentration, that is, the lower value on range 1 must be set less than that of range 2. Similarly, the lower value of range 2 must be less than that of range 3.

The Model 3010MA is set at the factory to default to autoranging. In this mode, the microprocessor automatically responds to concentration changes by switching ranges for optimum readout sensitivity. If the current range limits are exceeded, the instrument will automatically shift to the next higher range. If the concentration falls slightly below full scale of the next lower range, the instrument will switch to that range. A corresponding shift in the DC percent-of-range output, and in the range ID outputs, will be noticed.

The autoranging feature can be overridden so that analog output stays on a fixed range regardless of the oxygen concentration detected.

Note: If the concentration exceeds the upper limit of the range, the DC output will saturate at 1VDC.

However, the digital readout and the RS-232 output of the concentration are unaffected by the fixed range. They continue to read accurately with full precision. See *Front Panel* description in Chapter 1.

4.6.1 Setting the Analog Output Ranges

To set the ranges, enter the range function mode by pressing the *Range* button on the front panel.

L-0.00 M-95.00
H-98.00 Mode-AUTO

Use the < > arrow keys to blink the range to be set: low (L), medium (M), or high (H).

Use the $\Delta \nabla$ arrow keys to enter the bottom value of the range (all ranges end at 100 %). Repeat for each range you want to set. Press *Enter* to accept the values and return to *Analyze* mode. (See note below.)

Note: The ranges must be increasing from low to high. For example, if range 1 is set as 95-100 % and range 2 is set as 98-100 %, range 3 cannot be set as 96-100 % since it is lower than range 2.

4.6.2 Autoranging Analysis

Set your analysis ranges as in 4.6.1, above. Leave Mode in Auto, or use the arrow buttons to change back to Auto.

4.6.3 Fixed Range Analysis

The autoranging mode of the instrument can be overridden, forcing the analyzer DC outputs to stay in a single predetermined range.

To switch from autoranging to fixed range analysis, enter the range function by pressing the *Range* button on the front panel.

Use the < > arrow keys to move the blinking over AUTO.

Use the $\Delta \nabla$ arrow keys to switch from AUTO to FX/LO, FX/MED, or FX/HI to set the instrument on the desired fixed range (low, medium, or high).

L-0.00 M-95.00
H-98.00 Mode-FX/LO

or

L-0.00 M-95.00
H-98.00 Mode-FX/MED

or

L-0.00 M-95.00
H-98.00 Mode-FX/HI

Press *Escape* to re-enter the *Analyze* mode using the fixed range.

NOTE: When performing analysis on a fixed range, if the oxygen concentration rises above 100% O₂ upper limit (default value) the output saturates at 1VDC. If the reading goes below the minimum range value the output voltage will drop to zeroVDC. However, the digital readout and the RS-232 output continue to read the true value of the oxygen concentration regardless of the analog output range. Oxygen values below 0% or above 100% should not be considered valid.

4.7 The Analyze Function

Normally, all of the functions automatically switch back to the *Analyze* function when they have completed their assigned operations. Pressing the *Escape* button in many cases also switches the analyzer back to the *Analyze* function. Alternatively, you can press the *Analyze* button at any time to return to analyzing your sample.

4.8 Signal Output

The standard Model 3010MA Paramagnetic Oxygen Purity Analyzer is equipped with two 0–1VDC analog output terminals accessible on the back panel (one concentration and one range ID). The standard model also includes one isolated 4–20 mA dc current outputs for the oxygen concentration.

See *Rear Panel* in Chapter 3, *Installation*, for illustration.

The signal output for concentration is linear over the currently selected analysis range. For example, if the analyzer is set on range that was defined as 98–100% O₂, then the output would be:

Table 4.1: Linear Analog Output

% Oxygen	Voltage Signal Output (V dc)	Current Signal Output (mA dc)
98.0	0	4
98.2	0.1	5.6
98.4	0.2	7.2

98.6	0.3	8.8
98.8	0.4	10.4
99.0	0.5	12
99.2	0.6	13.6
99.4	0.7	15.2
99.6	0.8	16.8
99.8	0.9	18.4
100	1.0	20

The analog output signal has a voltage which depends on the oxygen concentration AND the currently activated analysis range. To relate the signal output to the actual concentration, it is necessary to know what range the instrument is currently on, especially when the analyzer is in the autoranging mode.

To provide an indication of the range, a second pair of analog output terminals are used. They generate a steady preset voltage (or current if you have current outputs) to represent a particular range. The following table gives the range ID output for each analysis range (Note: the 4-20mA Range ID output is a special option):

Table 4-2: Range ID Output

Range	Voltage (V)	Current (mA)
LO	0.25	8
MED	0.5	12
HI	.75	16

Maintenance

5.1 Routine Maintenance

Aside from normal cleaning and checking for leaks at the gas connections, routine maintenance is limited to replacing fuses, and recalibration. For recalibration, see Section 4.4 *The Zero and Span Functions*.

WARNING: SEE WARNINGS ON THE TITLE PAGE OF THIS MANUAL.



5.2 Fuse Replacement

The fuse compartment is located adjacent to the universal power supply on the rear panel of the Control Unit. To remove or replace a fuse:

1. Place small screwdriver in notch, and pry cover off, as shown in Figure 5-1.

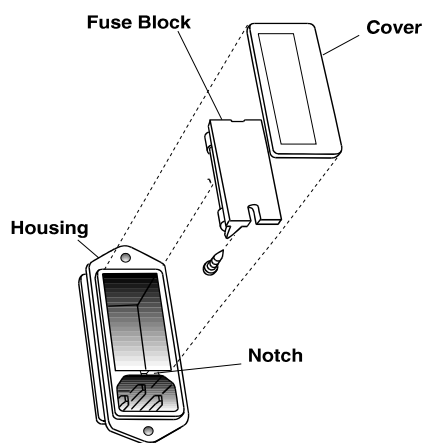

Figure 5-1: Removing Fuse Block from Housing

2. To change between American and European fuses, remove the single retaining screw, flip Fuse Block over 180 degrees, and replace screw.
3. Replace fuse as shown in Figure 5-2.
4. Reassemble Housing as shown in Figure 5-1.

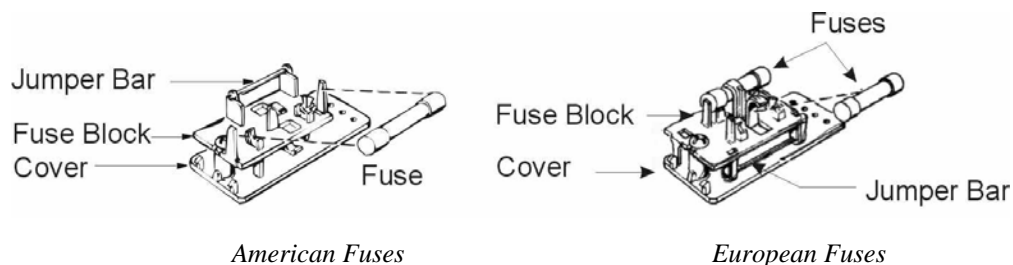

Figure 5-2: Installing Fuses

5.3 System Self Diagnostic Test

1. Press the *System* button to enter the system mode.
2. Use the < > arrow keys to move to More, and press *Enter*.
3. Use the < > arrow keys to move to Self-Test, and press *Enter*.

The following failure codes apply:

Table 5-1: Self-Test Failure Codes

Power	
0	OK
1	5 V Failure
2	15 V Failure
3	Both failed
Analog	
0	OK
1	D/A A (0-1 V Concentration)
2	D/A B (0-1 V Range ID)
3	Both Failed

Preamp

0	OK
1	Zero Too High
2	Amplifier output doesn't match test input
3	Both Failed

5.4 Major Internal Components

WARNINGS: SEE WARNINGS ON THE TITLE PAGE OF THIS MANUAL.



WARNING: UNPLUG THE POWER CORD FROM THE POWER SOURCE PRIOR TO OPENING THE INSTRUMENT FOR MAINTENANCE OR CLEANING.



The 3010MA is comprised of the Control unit and the Analysis Unit. The Control Unit is separate from the Analysis Unit to improve thermal stability and isolate the sensor. Each unit is maintained separately.

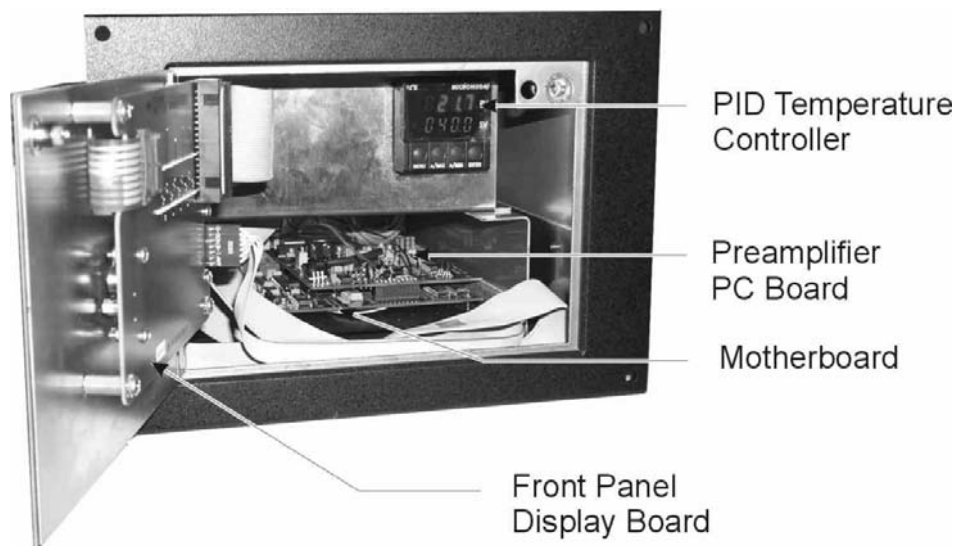

Figure 5-3: Internal Components of the Control Unit

The Control Unit Contains:

- 2 Power Supplies
- Motherboard (with microprocessor, RS-232 chip, preamplifier PCB, and pressure compensation circuitry)
- Front Panel Display Board
- 5 digit LED meter
- 2 line, 20 character, alphanumeric, VFD display
- Temperature Controller

The Analysis Unit contains:

- Paramagnetic sensor
- Sample System with flowmeter
- Oven

The major components of the Control Unit are shown in Figure 5-3. The 24V sensor power supply is located along side of the temperature controller. The control unit power supply is located on the rear panel PCB. These components are not visible in this picture.

See also the drawings located in the Drawings section at the back of this manual.

The Front Panel Display, LED and display PCB as well as the temperature controller are accessible from the front simply by swinging opening the front panel. Use a small screwdriver or other implement less than 0.18 inch wide and press on the button in the center of the latch in the upper right hand corner of the panel. The panel is hinged on the left side and will swing open like a door.

WARNING: HAZARDOUS VOLTAGES EXIST INSIDE THE CONTROL UNIT WHICH MAY PERSIST EVEN AFTER THE POWER HAS BEEN TURNED OFF AND DISCONNECTED.



THE INSTRUMENT REMAINS ENERGIZED EVEN AFTER THE STANDBY BUTTON ON THE LOWER RIGHT OF THE FRONT PANEL IS PRESSED. THIS BUTTON ONLY REMOVES POWER FROM THE DISPLAYS AND THE OUTPUTS. THE REST OF THE INSTRUMENT IS STILL ENERGIZED.

To access the Universal Power Supply and electronic PCB's, the rear panel must be removed. This is accomplished by removing the 10 cross-head screws at the locations shown in Figure 5-4.

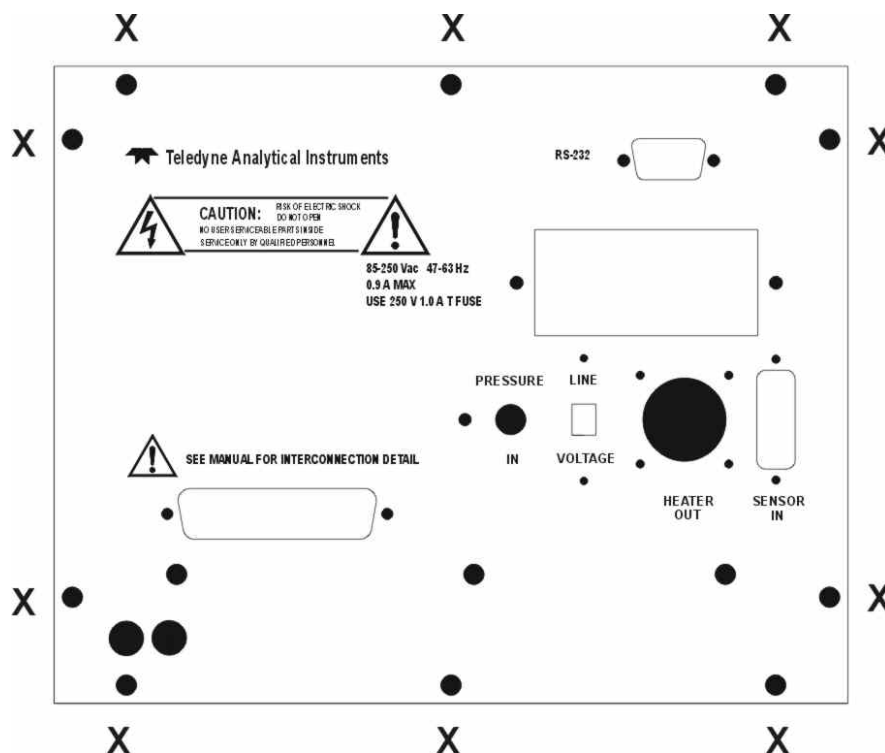

Figure 5-4: Rear-Panel Screws

5.5 Cleaning

If the instrument is unmounted at the time of cleaning, disconnect the instrument from the power source. Close and latch the front-panel access door. Clean outside surfaces with a soft cloth dampened slightly with plain clean water. Do not use any harsh solvents such as paint thinner or benzene.

For panel-mounted instruments, clean the front panel as prescribed in the above paragraph. DO NOT wipe the front panel while the instrument is controlling your process.

OPERATING INSTRUCTIONS

Model 3010MA

Paramagnetic Oxygen Purity Analyzer

Part II: Analysis Unit

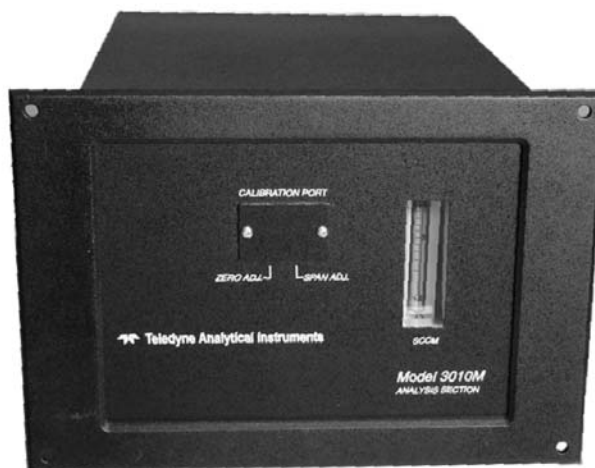

Analysis Unit

6.1 Overview

The Model 3010MA Paramagnetic Oxygen Purity Analyzer is a versatile instrument for accurately measuring percent oxygen concentration in oxygen rich gas sample streams. Three user-definable analysis ranges from 0-100% oxygen are available with auto-ranging and range ID contacts. The analyzer employs a paramagnetic sensor and a “split architecture” design to provide stable analysis across the instrument’s analysis range. The Model 3010MA provides both voltage (0-1VDC) and current (4-20 mA dc) outputs as a standard feature and linear across the entire analysis range.

The Model 3010MA uses a “split architecture” design with the Control Unit physically separate from the Analysis Unit to provide additional stability for the paramagnetic sensor. These units are for indoor use in a nonhazardous environment.

Part I of this manual covers the Control Unit while this part describes the Analysis Unit. Installation of both units is covered in Part I Chapter 3.

The Analysis Unit contains:

- Paramagnetic Cell
- Oven and Temperature Sensor
- Sample System

The Control Unit contains:

- Operator Interface
- Main circuit board
- PID temperature controller
- Pressure compensation circuitry
- 24VDC power supply for driving the Analysis Unit
- Digital meter readout and display circuit board
- Interface screen and circuit board

6.2 Paramagnetic Sensor

The paramagnetic sensor is sensitive to pressure and temperature variations. The sensor used in the model 3010MA includes a preamp and an internal temperature controller set to 55°C. The entire sensor assembly is housed in an oven to further insulate the sensor from thermal fluctuations.

The sensor produces a linear output from 0-1.2VDC, and operates over the range of 0-100% oxygen. The sensor has zero and span trimpots for calibration.

6.2.1 Principles of Operation

The heart of the 3010MA is a paramagnetic type oxygen sensor that is maintenance free and has a long lifetime. Oxygen has a very high magnetic susceptibility compared to other gases and thus takes on a distinct magnetic behavior when influenced by another magnet or positioned in a magnetic field. This is referred to as paramagnetic behavior.

A small glass dumbbell filled with nitrogen and rotating on a taut platinum wire is suspended in an inhomogeneous magnetic field surrounded by sample gas. This glass dumbbell is diamagnetic (does not respond or only weakly responds to a magnetic influence) and tends to rotate out of the magnetic field depending on the magnetic susceptibility of the sample gas. The rotation of the dumbbell produces a torque that is proportional to the magnetic susceptibility of the sample gas. This torque is compensated for by a counter torque induced by an electrically charged platinum coil on the dumbbell.

The zero position of the dumbbell is controlled by means of an optical system consisting of a light source, a mirror at the dumbbell axis and a pair of detectors. The difference between the compensating currents required to bring the dumbbell to the zero position in the presence of zero gas (i.e. no O₂ present) or of sample gas is proportional to the partial pressure of oxygen in the sample gas.

The sensor enclosure is temperature controlled to 55 degrees centigrade to insure that the magnetic susceptibility of oxygen in the sample is not affected by the ambient temperature. The measuring cell has a measuring volume of approximately 3 cm³.

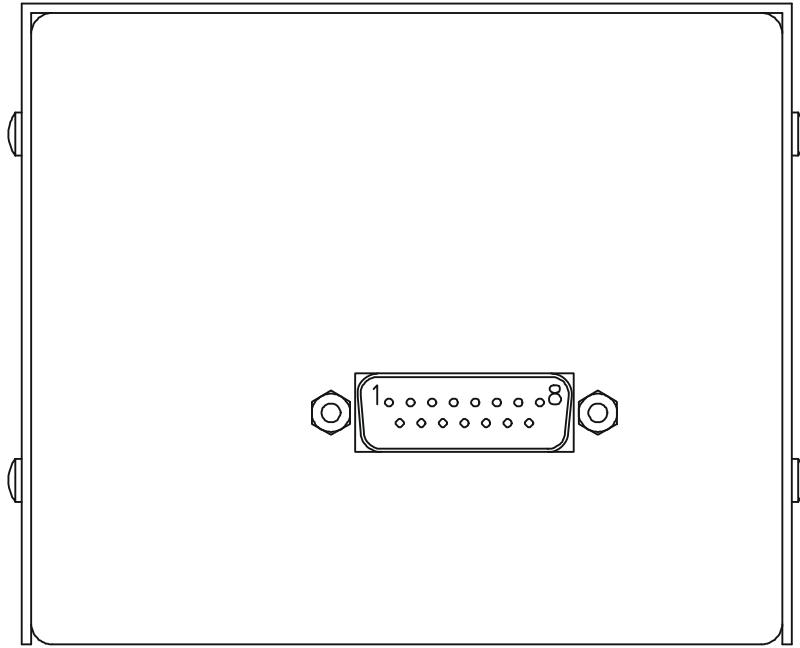

Figure 6-1: Side view of Paramagnetic Sensor



Figure 6-2: Front View of the Paramagnetic Sensor

The Paramagnetic sensor and heating elements are contained within the Analysis Unit but the temperature controller, sensor electronics, preamplifier and compensation circuitry are located in the Control Unit and interfaced to the Analysis Unit via the rear panel cable connections. Figure 6-1 is a drawing showing the front view of the paramagnetic sensor. Note the location of the Zero and Span adjustments on the upper left side of the sensor. Figure 6-2 is a drawing showing the side of the sensor. Figure 6-3 shows the actual sensor and the location of the zero and span trimpots.

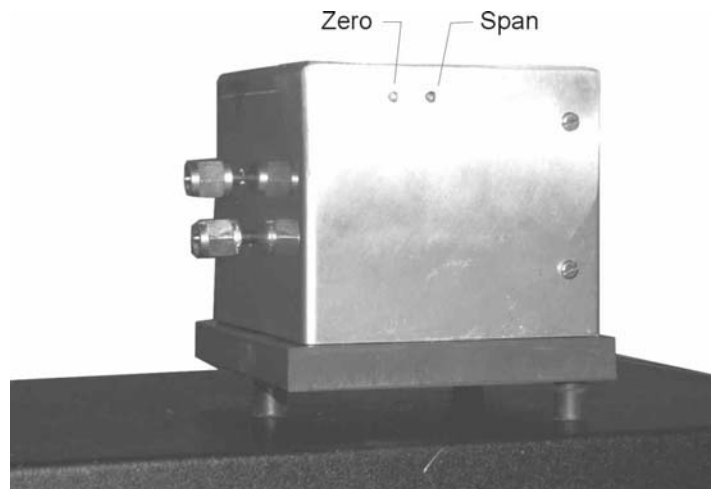

Figure 6-3: Sensor and Trimpot Identification

The electrical interconnections to the sensor are done through a 15-pin D-Sub connector. Some signals from the sensor are not connected. They are only useful for troubleshooting, by trained personnel, as test points. A separate cable is used for heating element power. Table 6-1 indicates the pin connections within the sensor cable while Figure 6-4 shows the sensor cable and identifies the pin locations.

Table 6-1: Sensor Cable Pin Configuration

Pin #	Description
1	-15Vdc test pin (Not connected)
2	+15Vdc test pin (Not connected)
3	Measuring ground

- 4 Not used
- 5 Pre-amplifier output ~0- 1VDC
- 6 Not used
- 7 24VDC return, power ground
- 8 Collector of transistor switching heating element (Not con-
- 9 Fault signal: <0VDC= OK, >4.6VDC = Fault (Not connected)
- 10 Not used
- 11 Negative reference voltage (Not connected)
- 12 Positive reference voltage (Not connected)
- 13 Nominal temperature voltage signal (Not connected)
- 14 Actual temperature voltage signal (Not connected)
- 15 +24VDC power.

The Electronics and heating elements require a separate power supply (also housed in the Control Unit) capable of delivering approximately 1.5 amps at 24 volts dc. The output of the sensor is roughly calibrated to be 0 to 1 volt DC for the range of 0 to 100% O₂. The true calibration of the sensor is carried out by the microprocessor as described in Part I Chapter 4.

6.2.2 Cross Interference

As mentioned previously, the selectivity of the measuring system is based on the extraordinarily high magnetic susceptibility of oxygen compared to other gases. In most cases the presence of other gases can be ignored but significant errors can occur when the sensor is calibrated with a mixture of oxygen and nitrogen and the sample gas consists mainly of other gases with considerable magnetic susceptibility. In this case, the reading shows a measured value even if the sample gas contains no Oxygen. It is actually displaying the cross sensitivity to another gas.

Table 6-2 shows the cross sensitivity of some gases when changing from pure nitrogen to 100% of one of the gases listed.

With gas mixtures the components are weighted according to their proportional volumes.

The cross interference with a gas mixture can be determined in advance if the concentration of the individual background gases is known.

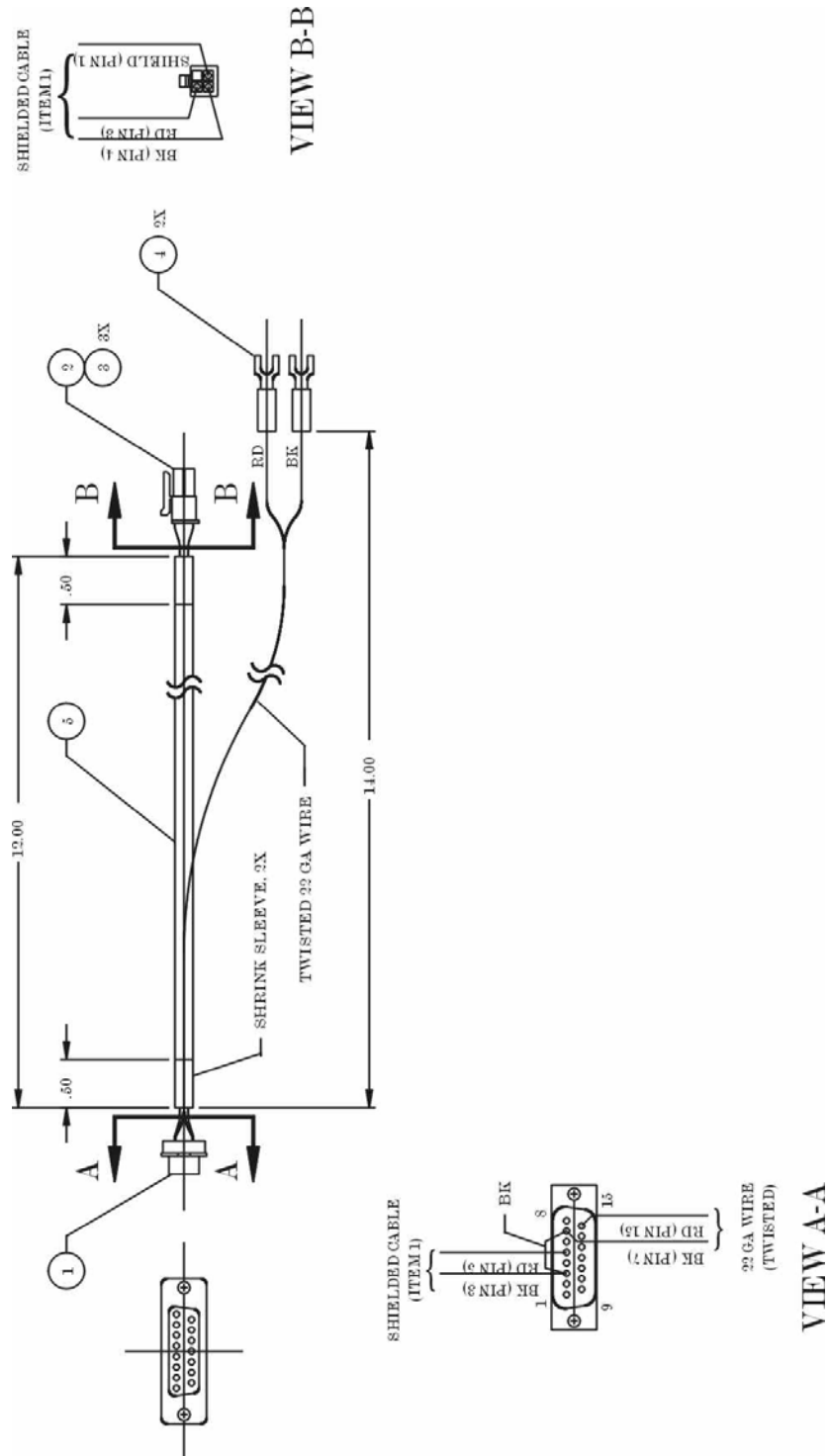

Figure 6-4: 15-Pin Sensor Cable and Pin Identification

Example:

Cross sensitivity calculation for a gas mixture:

The gas to be measured consists of 10 % CO₂, 40 % N₂, and 50% Ar.

$$\text{CO}_2 : 0.27 \times 10\% = -0.027$$

$$\text{Ar} : 0.22 \times 50\% = -0.110$$

$$\text{Total Cross Interference} : = -0.137$$

Calculation of the zero value:

$$0\% \text{ O}_2 - \text{Cross Interference Value} = \text{Zero Point Value}$$

$$0\% - (-0.137) = +0.137$$

Table 6-2: Cross Sensitivity of Various Gases

Gas	Cross Sensitivity in vol. %	Gas	Cross Sensitivity in vol. %
Acetylene C ₂ H ₂	-0.24	Hydrogen chloride HCl	-0.30
Allene C ₃ H ₄	-0.44	Hydrogen Fluoride HF	+0.10
Ammonia NH ₃	-0.26	Hydrogen Iodide HI	-1.10
Argon Ar	-0.22	Hydrogen Sulphide H ₂ S	-0.39
Bromine Br ₂	-1.30	Iodine I ₂	-2.40
1.2 Butadiene C ₄ H ₆	-0.49	Isobutane C ₄ H ₁₀	-1.11
1.3 Butadiene C ₄ H ₆	-0.49	Isopentane C ₅ H ₁₂	-1.49
n-Butane C ₄ H ₁₀	-1.11	Krypton Kr	-0.51
l-Butane C ₄ H ₁₀	-0.85	Laughing gas N ₂ O	-0.20
cis 2- Butene C ₄ H ₈	-0.89	Methane CH ₄	-0.20
trans 2 Butene C ₄ H ₈	-0.92	Neon Ne	+0.13
Carbon dioxide CO ₂	-0.27	Neopentane C ₅ H ₁₂	-1.49
Carbon monoxide CO	+0.06	Nitric acid HNO ₃	+0.43
Chlorine Cl ₂	-0.77	Nitrogen dioxide NO ₂	+28.00

Cyclo hexane C ₆ H ₁₂	-1.56	Nitric oxide NO	+40.00
Ethane C ₂ H ₆	-0.43	n-Octane C ₈ H ₁₈	-2.50
Ethylene C ₂ H ₄	-0.26	n-Pentane C ₅ H ₁₂	-1.45
Helium He	+0.30	Propane C ₃ H ₈	-0.86
n-Heptane C ₇ H ₁₆	-2.10	Propylene C ₃ H ₆	-0.55
n-Hexane C ₆ H ₁₄	-1.70	Vinyl chloride	-0.63
Hydrogen H ₂	+0.24	Water H ₂ O	-0.02
Hydrogen bromide HBr	-0.61	Xenon Xe	-0.95

6.3 Oven and Temperature Controller

The oven in the Analysis Unit is used to provide thermal stability to the sensor assembly is comprised of dual 40 watt heaters powered by 115 or 230 V ac from the Control Unit. The oven temperature is maintained at 40°C by a PID temperature controller housed in the Control Unit. An RTD sensor is mounted in the Analysis Unit to provide feedback to the PID controller. The temperature in the Analysis Unit at any time can be read from the display on the temperature controller after opening the front panel of the Control Unit. See Figure 6-5. This can be done without affecting the thermal environment of the Analysis Unit.

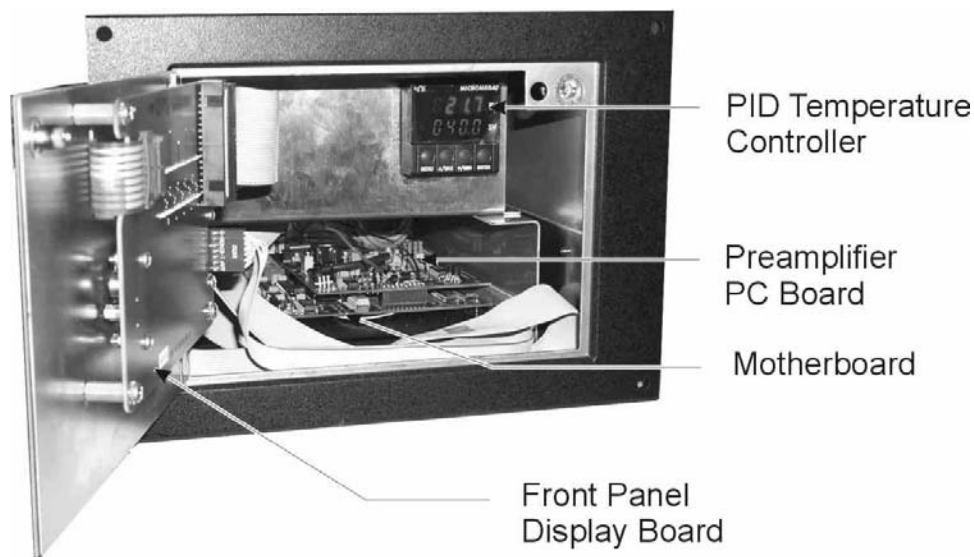

Figure 6-5: Access to Temperature Controller in Control Unit

6.4 Sample System

The paramagnetic sensor used in the Model 3010MA is a partial pressure device and is sensitive to pressure variations both at the point of entry into the system and the sample exit (atmospheric pressure). For example, a 1% change in vent pressure will cause a corresponding 1% variation in the oxygen reading.

For higher accuracy, a pressure compensation circuit is installed to compensate for vent pressure fluctuations. A 1/8 inch line continuously samples the pressure at the sensor outlet in the Analysis unit and delivers it to the pressure compensation circuit within the Control Unit. The raw output from the sensor is corrected for pressure variation using a baseline pressure set during instrument calibration. The output is adjusted electronically based on the pressure differential between the present reading and the baseline set during the last calibration.

The linear range of the uncorrected sensor output is 0-1.2VDC. For proper operation, the raw output must be adjusted to 0VDC at 0% O₂ and 1VDC at 100% O₂. This allows the sensor output to remain linear during minor atmospheric fluctuations. The raw sensor output can be accessed from the alphanumeric display by using the System key.

On the inlet side, the Model 3010MA is supplied with an externally mounted flow restrictor to limit the sample flow to 300-1000 SCCM. The actual restrictor recommended depends on the users sample pressure. Note that the restrictor can be replaced with a metering valve for more flexibility. The standard units are supplied with PN: R2533. Table 6-3 identifies restrictors available for the pressure ranges shown as well as available metering valves.

Table 6-3: Pressure Ranges of Available Restrictors

PRESSURE RANGE	TAI RESTRICTOR
2-5 psig	TAI P/N R2532
5-15 psig	TAI P/N R2533
10-20 psig	TAI P/N R2534
15-30 psig	TAI P/N R2535
Brass metering valve	TAI P/N V744
SS metering valve	TAI P/N V745



The sample system delivers gases to the sensor from the gas inlet located on the rear panel of the Analysis Unit. **Note: There is no flow limiting device inside the analysis unit and the flow rate must not exceed 1000 SCCM.** The Model 3010MA sample system is designed and fabricated to ensure that the oxygen concentration of the gas is not altered as it travels through the sample system. The sample encounters almost no dead space. This minimizes residual gas pockets that can reduce response time. The sample system is shown in Figure 6-6. This figure also shows the user supplied components for selecting and delivering sample and calibration gases to the Analysis Unit. If the auto calibration feature is to be used, additional solenoid valves must be installed to allow automatic sequencing of calibration and sample gases and tied in to the 50-pin equipment interface connector as described in Part I Chapter 3 Section 3.3.2.3.

The rear panel of the Analysis Unit incorporates ¼ inch tube fittings for sample inlet and outlet connections from the user's sample system. For metric system installations, 6 mm adapters are available with each instrument to be used if needed. The sample or calibration gas flowing through the system is monitored by a flowmeter downstream from the sensor. The gases delivered to the instrument should be at constant pressure and have constant flow rates. They must exit freely to the ambient atmosphere. The span, zero and sample gases should be delivered at constant pressures of about 10 psig (Range 5-25 psig.) with standard restrictor. The flow rate must be maintained at about 500 cc/minute (range 300-1000 SCCM) and must exit freely to atmospheric pressure.

Referring to Figure 6-3, in the standard instrument, calibration gases (zero and span) can be connected directly to the Sample In port by teeing to the port with appropriate valves.

Prior to entering the instrument it is recommended that the sample gas be passed through a 50 micron or finer filter. Calibration gases with appropriate valves should be teed into the inlet line upstream of the filter. A flow restrictor is supplied with the instrument and should be installed between the filter and the gas inlet port. This limits the gas flow rate through the paramagnetic cell. A flowmeter is installed on the exit side of the cell which is visible on the Analysis Unit front panel (see Figure 6-7) The flowmeter is used to monitor the flow of gas through the sensor. Readout is 0 to 1000 standard cubic centimeters per minute (SCCM).

Flow should be adjusted within the range 300-1000 SCCM, optimally 500 SCCM and should be stable. A 1/8 inch line is installed on the vent

side of the sensor for the pressure compensation. This line is fed to the pressure compensation circuit in the Control Unit and is vented to atmospheric pressure at the Control Unit.

A bypass loop can be installed around the analysis unit to improve the overall response time of the instrument. If such a loop is used, make sure that the inlet flow at the analyzer is within the 300-1000 SCCM.

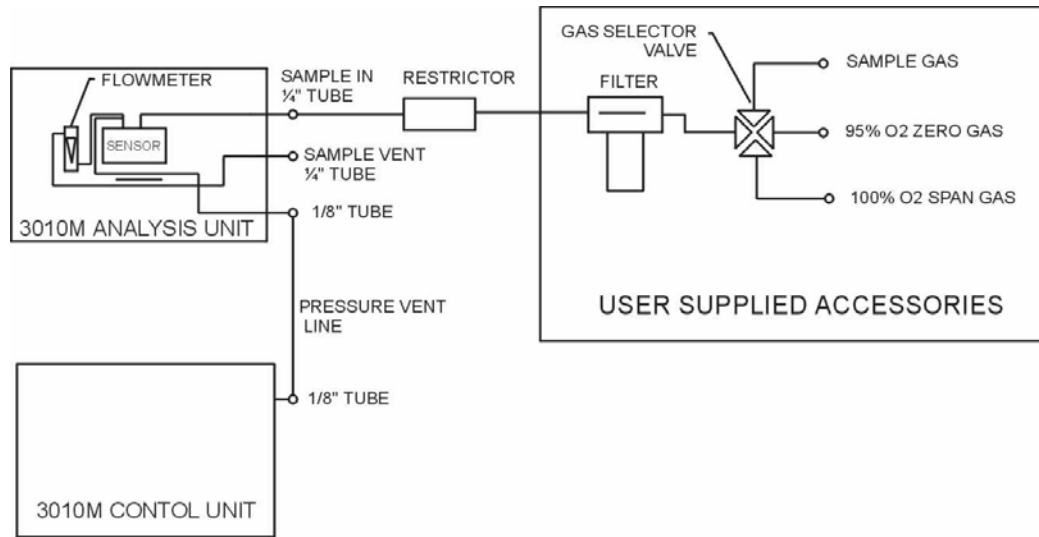

Figure 6-6: Piping Diagram for Model 3010MA

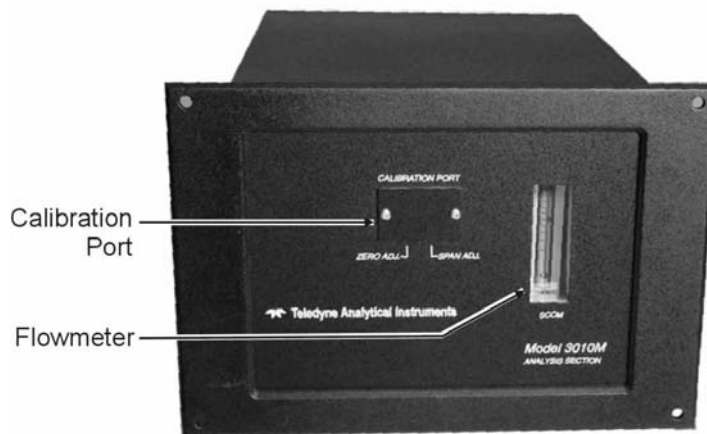

Figure 6-7: Analysis Unit Front Panel

If remote gas selection is desired, the user must supply 3 two-way 24VDC solenoid actuated valves, one for span, zero and sample gas. These valves are tied into the 50-Pin Equipment Interface connector as described in Section 3.3.2.3.

NOTE: The automatic calibration feature of this analyzer can still be used even without remote valve operation however, the appropriate gas (zero, span or sample) must be selected manually. Calibrating this instrument using the wrong gas i.e. zero gas instead of span gas, will result in inaccurate analysis.

6.5 Leak Checking the Analysis Unit

The internal piping in the Analysis Unit has been assembled and leak checked at the factory however it is wise to recheck all lines and fittings to ensure that the system remains leak free.

CAUTION: THE SENSOR MUST NOT BE EXPOSED TO PRESSURE IN EXCESS OF 14 PSIG WHEN LEAK TESTING.



The most expedient way to leak check the system is to use a commercial soap solution and pressurize the system using clean air, nitrogen or other non-toxic, non-flammable gas to 10 psig or less. Apply the soap solution and watch for vigorous bubbling. A certain amount of low intensity bubble activity is normal such as bubbles collapsing under atmospheric pressure. If a leak occurs, it will show as a continuous activity and be much more pronounced than the surrounding bubble activity.

Check each fitting entering and exiting the analyzer including the pressure compensation line at the Control Unit. If a leak occurs at a fitting, tighten the fitting an additional 1/8 to 1/4 turn. If the leak persists after tightening, replace the fitting.

When the system is leak-free, continue flushing with the gas used for leak checking for 15 minutes. Then disconnect the leak check gas and reconnect the sample gas.

6.6 Initial Sensor Calibration

Prior to using the analyzer for the first time, an initial sensor calibration may be required. The sensor must also be purged for 24 hours as described in Part 1 Section 3.6. The specific steps to perform this calibration will be outlined here however, the procedure will be easier to follow after reading Chapter 4, *Operation*.

As mentioned in Chapter 2, the paramagnetic sensor used in this instrument is sensitive to the vent pressure (usually atmospheric). The initial sensor calibration is done at the factory during production testing however, if the users installation sample vent pressure is significantly different from that of our factory, the sensor will need to be recalibrated to ensure that it is operating in it's linear range.

To determine if the sensor needs to be calibrated, the analyzer must be operated on 100% O₂ span gas. Allow the analyzer to stabilize for 2 hours. Select *System* with front panel controls on the Control Unit. Select *More* with the soft key. The sensor output will be displayed on the alphanumeric display. The sensor output should be between 0.98 – 1.02VDC. If not, perform the sensor initial calibration procedure.

For this procedure use a zero gas of 0% oxygen and span gas of 100% oxygen. An appropriate sample system must be installed as outlined above. The flow rate should be set to 500 SCCM or to the users operating flow rate (within 300- 1000 SCCM range). Both the zero gas (0% O₂ balance N₂) and the span gas (100% O₂).

To perform the initial calibration:

1. Assuming that the instrument is installed properly and gas line connections including sample-in, zero and span (although only zero and span gas will be used in this procedure) have been made and leak-checked, turn the system on by plugging the power cord into an appropriate power outlet. It is important that the sample vent from the Analysis Unit is connected at the location that it will be used in and that the pressure vent line is connected between the Analysis Unit and The Control Unit.
2. Allow the Model 3010MA to stabilize for a minimum of 2 hours. This is required for the sensor and the oven in the Analysis Unit to equilibrate at the operating temperature. The temperature controller in the Control Unit has been set to 40°C. You may verify this by opening the Control Unit front panel and looking at the controller display. Both the actual temperature and the setpoint are displayed.
3. During the last hour of stabilization, introduce span gas (100% O₂) by opening the appropriate valve and adjust the flow rate to 500 SCCM. (The flow rate should be set to 500 SCCM or to the users operating flow rate (within 300-1000 SCCM range).
4. After the stabilization period has expired, select press *SYSTEM* on the front panel of the Control Unit. Use the < >

arrow keys to blink More, The voltage output of the cell is displayed on the second screen of the System menu.

5. Remove the Calibration Port cover located on the front panel of the Analysis Unit. (See Figure 6.3). Use a long thin screwdriver, locate and adjust the sensor output to 1.0VDC by turning the **right** trim screw on the front of the sensor. The output on the VFD display should read between 1.0 - 0.98VDC.
6. Close the valve to the span gas and open the valve to the zero gas. Again, adjust the flow to same flow that was used for the span gas. Adjust the **left** trim screw on the sensor until the cell output reads 0VDC (0.00-0.02)VDC. Close the zero gas valve.
7. Repeat steps 2-6 and verify that the sensor is operating within the given limits.

The initial calibration of the sensor is now complete. Only if there is a significant change in vent pressure will this process need to be repeated.

After sensor calibration, the analyzer must be calibrated using the 0% oxygen as a zero gas and 100% oxygen as the span gas. It is convenient to proceed with this now since the analyzer is currently set-up for calibration. Refer to Section 4.4.

Appendix

A-1 Model 3010MA Specifications

Sensor: Paramagnetic

Range: 3 ranges, user selectable from 0-100% O₂

Alarms: One system-failure alarm contact to detect power failure

Two adjustable concentration threshold alarms with fully programmable setpoints.

Displays: 2 line by 20 character, alphanumeric, VFD screen
One 5 digit LED display

Digital Interface: Full duplex RS-232 communications port.

Power: 100-130, or 200-240 VAC, at 47/63 Hz.
(User selected on rear of control unit)

Operating Temperature: 20-30 °C

Accuracy: ±0.045% O₂ absolute at constant temperature (once thermal equilibrium has been achieved)
±0.05% O₂ over operating temperature range 20-30°C (once thermal equilibrium has been achieved)

Response Time: 10% - 90% in 14 sec @ 600 SCCM

Analog outputs: 0-1VDC percent-of-range (Standard)
0-1VDC range ID (Standard)
4-20 mA dc—isolated— percent-of-range
4-20 mA dc—isolated— range ID (Special option)

Dimensions: 17.7 cm high × 24.9 cm wide × 30.5 cm deep (6.96" × 8.7" × 12.2").

Weight: Analysis: (7.8Kg) 17.2Lbs

Control unit: (8.2 Kg) 18Lbs

Approvals: CE mark

Area Classification: General Purpose

A-2 Recommended 2-Year Spare Parts List

Qty	Part Number	Description
1	C65507A	Rear Panel Board
1	C62371-B	Front Panel Board
1	C73699B	Paramagnetic Preamplifier Board
1	B73539	Heater control cable 24"
1	B73547	Sensor cable 24"
1	C72017	Main Computer Board (4-20 mA)
2	F10	Fuse, 2 A, 250 V, 3 AG, Slow Blow
3	F1296	Fuse, 2 A, 250 V, 5 × 20 mm, Slow Blow
2	F73	Ferrule 1/4" SS
2	F74	Ferrule 1/4" SS
2	N73	Nut 1/4" SS
1	R2533	Restrictor
1	V11	Union SS 1/4"
1	S1307	Screwdriver
6	F1586	Thermal fuse
1	F1584	Blower/fan

NOTE: Orders for replacement parts should include the part number (if available) and the model and serial number of the instrument for which the parts are intended.

Orders should be sent to:

TELEDYNE Analytical Instruments

16830 Chestnut Street
City of Industry, CA 91749-1580

Phone (626) 934-1500, Fax (626) 961-2538
TWX (910) 584-1887 TDYANYL COID

Web: www.teledyne-ai.com

or your local representative.

A-3 Drawing List

D-73635 Outline Drawing

B-73695 Piping Diagram

A.4 Programmable Pressure Compensation Adjustment

The standard model 3010MA software includes pressure compensation of the sensor in a 1 to 1 relation with atmospheric pressure change. While this is adequate for most applications, sometimes small errors in the O₂ reading are observed when pressure compensation is slightly off. The latest version of the 3010M software provides a pressure compensation factor to allow the user to fine tune compensation.

PROCEDURE:

By default, the 3010M's uses a 1:1 compensation ratio. That is, if the atmospheric pressure increases by 1%, the software will reduce the O₂ reading by 1%. To find the optimum pressure compensation factor, the analyzer should be set up as follows and the procedure followed carefully.

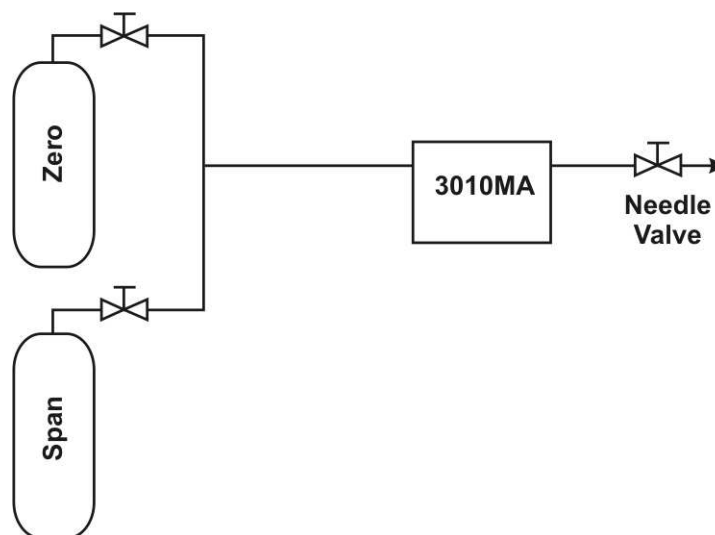

1. Verify the pressure compensation factor is set to 1.00.

- While the analyzer is in the Analyze mode
- Press the *System* key
- Find and select the 'PressureAdj' function
- Press the *Enter* key
- Verify that the compensation factor is set to 1.00, adjust if required
- Press the *Escape* key

2. **Zero (with N₂ gas) the analyzer with no restriction on vent (needle valve fully open)**
3. **Span (with O₂ gas) the analyzer with no restriction on vent (needle valve fully open)**
4. **Change pressure compensation factor to 0.00**
 - Press the *System* key
 - select the 'PressureAdj' function
 - Then press *Enter*
 - Verify that the compensation factor is set to 0.00, adjust if required
 - Press the *Escape* key
5. **Record the oxygen reading with the span gas flowing, (100% O₂) and needle valve on the vent fully open.**
 - Press the *System* key
 - Select the 'More' function
 - On the second System screen, record the A to D pressure counts. The A to D pressure counts are shown on the second line of the VFD. The example below would be typical for a 3010M analyzer with Valve Box compatible software. The first number in the second line is the paramagnetic sensor voltage output (0.993VDC) and the second number is the A to D pressure counts (112210).

```
Ver Test Ser# Stream
0.993 112210 More
```

6. **Record the oxygen reading with the span gas flowing, (100% O₂) and needle valve on the vent slightly closed.**
 - While still on the second System screen, slowly begin to close the needle valve. Observe the A to D pressure counts as they rise, stop once the counts are approximately 1000 counts over the value you recorded in step 5 (the increase does not have to be exactly 1000 counts).
 - Wait for stability, about three to five minutes.
 - Return to the Analyze screen by pressing the *Analyze* key, record the oxygen reading.
7. **Compute the pressure compensation factor. See Example 1 shown below.**



Example 1:

With pressure compensation factor set to 0.00 and the vent needle valve fully open:

Oxygen: 100.01 Pressure: 122210

With pressure compensation factor set to 0.00 and the vent needle valve not fully open:

Oxygen: 101.15 Pressure: 123554

Percent change of oxygen:

$$100 \times \frac{100.15 - 100.01}{100.01} = 1.14$$

Percent change of pressure:

$$100 \times \frac{123554 - 122210}{122210} = 1.10$$

New Pressure compensation factor:

$$1.14 / 1.10 = 1.04$$

8. Input the New Pressure Compensation Factor calculated from your test data.

- Press the *System* key
- Select the 'PressureAdj' function
- Press the *Enter* key
- Adjust the value with Up/Down arrow keys to value you calculated (In Example 1 above, the New Pressure Compensation Factor would be set to '1.04')
- Press the *Enter* key.

The compensation is now set. The factor can still be tuned further, by repeating steps 5 through 8. The pressure compensation factor entered at the end of step 8 is now your starting factor. On the second, and further iterations, you will find less and less change in the O₂ reading. A change of 0.02 % O₂ or less would be acceptable. If it is more than that, go back

to the pressure compensation factor and change the value by 0.01, then repeat the test till the results are acceptable.