

---

OPERATING INSTRUCTIONS FOR

# Model 2120

## Trace Nitrogen in Argon Analyzer



P/N MXXXX

ECO:



**DANGER**



This instrument is for analyzing nitrogen in argon only.

Do not introduce any flammable or toxic gases into this instrument.

Hazardous voltages exist on certain components internally which may be lethal. Disconnect power before servicing.

Only authorized personnel should conduct maintenance and/or servicing. Before conducting any maintenance or servicing, consult with authorized supervisor/manager.

**Copyright © 2006 Teledyne Analytical Instruments**

All Rights Reserved. No part of this manual may be reproduced, transmitted, transcribed, stored in a retrieval system, or translated into any other language or computer language in whole or in part, in any form or by any means, whether it be electronic, mechanical, magnetic, optical, manual, or otherwise, without the prior written consent of Teledyne Analytical Instruments, 16830 Chestnut Street, City of Industry, CA 91749-1580.

**Warranty**

This equipment is sold subject to the mutual agreement that it is warranted by us free from defects of material and of construction, and that our liability shall be limited to replacing or repairing at our factory (without charge, except for transportation), or at customer plant at our option, any material or construction in which defects become apparent within one year from the date of shipment, except in cases where quotations or acknowledgements provide for a shorter period. Components manufactured by others bear the warranty of their manufacturer. This warranty does not cover defects caused by wear, accident, misuse, neglect or repairs other than those performed by Teledyne or an authorized service center. We assume no liability for direct or indirect damages of any kind and the purchaser by the acceptance of the equipment will assume all liability for any damage which may result from its use or misuse.

We reserve the right to employ any suitable material in the manufacture of our apparatus, and to make any alterations in the dimensions, shape or weight of any parts, in so far as such alterations do not adversely affect our warranty.

**Important Notice**

This instrument provides measurement readings to its user, and serves as a tool by which valuable data can be gathered. The information provided by the instrument may assist the user in eliminating potential hazards caused by his process; however, it is essential that all personnel involved in the use of the instrument or its interface, with the process being measured, be properly trained in the process itself, as well as all instrumentation related to it.

The safety of personnel is ultimately the responsibility of those who control process conditions. While this instrument may be able to provide early warning of imminent danger, it has no control over process conditions, and it can be misused. In particular, any alarm or control systems installed must be tested and understood, both as to how they operate and as to how they can be defeated. Any safeguards required such as locks, labels, or redundancy, must be provided by the user or specifically requested of Teledyne at the time the order is placed.

Therefore, the purchaser must be aware of the hazardous process conditions. The purchaser is responsible for the training of personnel, for providing hazard warning methods and instrumentation per the appropriate standards, and for ensuring that hazard warning devices and instrumentation are maintained and operated properly.

Teledyne Analytical Instruments, the manufacturer of this instrument, cannot accept responsibility for conditions beyond its knowledge and control. No statement expressed or implied by this document or any information disseminated by the manufacturer or its agents, is to be construed as a warranty of adequate safety control under the user's process conditions.

### Safety Messages

---

Your safety and the safety of others is very important. We have provided many important safety messages in this manual. Please read these messages carefully.

A safety message alerts you to potential hazards that could hurt you or others. Each safety message is associated with a safety alert symbol. These symbols are found in the manual and inside the instrument. The definition of these symbols is described below:



**GENERAL WARNING/CAUTION:** Refer to the instructions for details on the specific danger. These cautions warn of specific procedures which if not followed could cause bodily injury and/or damage the instrument.



**CAUTION: HOT SURFACE WARNING:** This warning is specific to heated components within the instrument. Failure to heed the warning could result in serious burns to skin and underlying tissue.



**WARNING: ELECTRICAL SHOCK HAZARD:** Dangerous voltages appear within this instrument. This warning is specific to an electrical hazard existing at or nearby the component or procedure under discussion. Failure to heed this warning could result in injury and/or death from electrocution.



*Technician Symbol:* All operations marked with this symbol are to be performed by qualified maintenance personnel only.

No  
Symbol

*NOTE:* Additional information and comments regarding a specific component or procedure are highlighted in the form of a note.

**CAUTION: THE ANALYZER SHOULD ONLY BE USED ONLY FOR THE PURPOSE AND IN THE MANNER DESCRIBED IN THIS MANUAL.**



**IF YOU USE THE ANALYZER IN A MANNER OTHER THAN THAT FOR WHICH IT WAS INTENDED, UNPREDICTABLE BEHAVIOR COULD RESULT POSSIBLY ACCOMPANIED WITH HAZARDOUS CONSEQUENCES.**

This manual provides information designed to guide you through the installation, calibration operation and maintenance of your new analyzer. Please read this manual and keep it available.

Occasionally, some instruments are customized for a particular application or features and/or options added per customer requests. Please check the front of this manual for any additional information in the form of an Addendum which discusses specific information, procedures, cautions and warnings that may be peculiar to your instrument.

Manuals do get lost. Additional manuals can be obtained from Teledyne at the address given in the Appendix. Some of our manuals are available in electronic form via the internet. Please visit our website at: [www.teledyne-ai.com](http://www.teledyne-ai.com).



## Table of Contents

---

<b>List of Figures</b> .....	<b>viii</b>
<b>List of Tables</b> .....	<b>ix</b>
<b>Introduction</b> .....	<b>1</b>
1.1 Overview	1
1.2 Typical Applications	1
1.3 Features	2
1.4 Front Panel	3
1.5 Rear Panel	4
1.6 Internal Components	6
1.7 Additional Safety Information	8
1.7.1 Emergency Procedures	9
1.7.2 Basic Safety Requirements	10
1.7.3 Precautionary Labels	10
1.7.4 Summary of Known Hazards	11
1.7.4.1 Electrocution	11
1.7.4.2 Pressure	11
1.7.4.3 Purging	12
1.7.4.4 Safe Repair Procedures	12
1.7.4.5 General Precautions for Handling and Storing High Pressure Gas Cylinders	13
<b>Operational Theory</b> .....	<b>15</b>
2.1 The Analyzer	15
2.2 Overrange Protection	16
2.3 Sample System	16
<b>Installation</b> .....	<b>19</b>
3.1 Unpacking the Instrument	19

3.2	Choosing a Location	20
3.3	Mounting	20
3.4	Electrical Connections	21
3.5	Gas Connections	22
3.5.1	Typical Sample System	23
3.5.2	Gas Connections to the Instrument	25
3.6	Purging	25
3.7	Calibration	26
3.8	Installation Checklist	27
<b>Operation .....</b>		<b>29</b>
4.1	Powering Up the Analyzer	30
4.2	Zero and Span Calibration	31
4.2.1	Before Calibration	31
4.2.2	Recommended Calibration Gases	31
4.2.3	Calibration Steps	32
4.3	Reading and Recording Data	33
4.4	Overrange Protection Circuit	34
<b>Maintenance .....</b>		<b>37</b>
5.1	Routine Maintenance	37
5.2	Routine Maintenance Schedule	37
5.3	Troubleshooting	38
5.4	Parts Replacement and Testing Guide	41
5.4.1	Voltage Selection and Fuse Changing	42
5.4.2	Optical Filter	43
5.4.3	Low Flow Switch	44
5.4.4	Control Relay	44
5.4.5	Analytical Cell	45
5.4.6	Photomultiplier Tube	46
5.4.7	High Voltage Plate Adjustment	47
5.4.8	High Voltage Transformer	47
5.4.9	Amplifier Board	48
5.4.10	Hamamatsu PMT High Voltage Supply	48

## Trace Nitrogen in Argon Analyzer

---

5.4.11 Low Voltage DC Supply Board	49
5.4.12 Regulated 255 Hz Power Supply	49
5.4.13 Digital Panel Meter	49
5.4.14 Zero and Span Potentiometers	50
<b>Appendix</b> .....	<b>51</b>
A.1 Specifications	51
A.2 Recommended Replacement Parts List	52
A.3 Sample Equipment Calibration Log Form	53
<b>Index</b> .....	<b>55</b>

## List of Figures

---

Figure 1-1 Model 2120 Front Panel.....	3
Figure 1-2: Model 2120 Rear Panel .....	5
Figure 1-3: Internal Component Identification .....	6
Figure 1-4: Internal Components in Card Cage.....	8
Figure 2-1 Block Diagram for the Model 2120 Analyzer .....	16
Figure 3-1: Analyzer Dimensions .....	21
Figure 3-2: Electrical Connections .....	22
Figure 3-3: Suggested Sample System.....	23
Figure 5-1: Power Entry Module.....	42
Figure 5-2: The Analytical Cell .....	45



### List of Tables

---

Table 5-1: Routine Maintenance Schedule.....	38
Table 5-2: Troubleshooting.....	39



This is a general purpose instrument designed for use in a non-hazardous area. It is the customer's responsibility to ensure safety especially when combustible gases are present since the potential of gas leaks always exist.

Never introduce gases other than argon into the analyzer. If explosive, flammable, or corrosive gases or gas mixtures are allowed to flow into the analyzer, fire or explosion can result.

To avoid serious injury, read all precautionary labels attached to equipment, cylinders, containers, and boxes prior to start-up.

Labels attached in appropriate areas of the analyzer warn you of inherent hazards associated with the system. For personal safety, read the labels and perform directed precautions before handling the equipment.

The customer should ensure that the principles of operating this equipment are well understood by the user. Misuse of this product in any manner, tampering with its components, or unauthorized substitution of any component may adversely affect the safety of this instrument.

Since the use of this instrument is beyond the control of Teledyne Instruments/ Analytical Instruments, referred as TI/AI, no responsibility by TI/AI, its affiliates, and agents for damage or injury from misuse or neglect of this equipment is implied or assumed.

## Introduction

---

### 1.1 Overview

This manual describes installation, operation and maintenance for the Model 2120 Trace Nitrogen in Argon Gas Analyzer. Section 1 describes the analyzer in general terms and provides additional safety information pertinent to the proper operation of the instrument.

The Teledyne Model 2120 Trace Nitrogen in Argon Gas Analyzer is a robust analytical tool for measuring trace amounts of nitrogen in argon. There are two separate instruments in the 2120 series to cover different analytical ranges:

Series 2120-A (115 V)      0-2 and 0-20 ppm

Series 2120-B (115 V)      0-20 and 0-200 ppm

For enhanced sensitivity extending to 10 ppb, the Model 2120 employs a photomultiplier tube (PMT) to optically distinguish the spectrum generated from an ionized sample gas oscillating at a specific frequency in the analytical cell. Using precise optical filtering, single line emission characteristic of nitrogen is produced with an intensity proportional to the nitrogen concentration. The nitrogen concentration is displayed on the front panel display meter and an analog output signal is available at the rear panel.

The system is easy to operate with all controls and indicators mounted on the front panel. Overrange protection alarm, low flow alarm, convenient test jack panel are just a few of the many features included on the standard Model 2120 instrument.

### 1.2 Typical Applications

The Model 2120 Trace Nitrogen in Argon Gas Analyzer is used in a wide range of applications including:

- Air separation plants
- Argon Purification Plants

- Specialty Gas Laboratories
- Specialty Steel Manufacturing
- Gas Management/Monitoring Systems
- Quality Control for Truck Fills & Gas Cylinders
- Process Control
- New Line Certification
- Chemical Plants
- Welding Gas Management
- Semiconductor Manufacturing

### 1.3 Features

The Model 2120 comes equipped with the following standard features:

- Digital Panel Meter—convenient and immediate display of the current sample analysis.
- Indicator lights—front panel mounted LEDs provide instrument status information at a glance.
- Overrange Protection—alarm contacts and LED.
- Range ID Contacts—outputs for range identification.
- Range Switch—allows for convenient switching between analysis ranges from the front panel.
- Zero and Span Controls—front panel mounted controls for calibration.
- PMT Voltage Adjustment Potentiometer—voltage adjustment for photomultiplier tube.
- Sample Flow Rotameter—for monitoring sample flow through the analytical cell.
- VCR Fitting—sample-in port connection fitting designed for leak-free sample delivery and analysis at trace levels.
- Optical Filter—optical filters for wavelength of impurity emission.



- Low Flow Switch—cuts power to the ionizer if the sample flow falls below a setpoint.

## 1.4 Front Panel

Operator controls and displays are located on the front panel as shown in Figure 1-1.

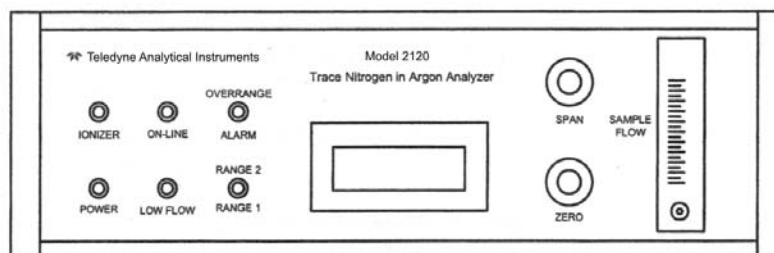

Figure 1-1 Model 2120 Front Panel

- **Status Indicator Lights:**
  - Ionizer Light —Illuminates when the 255 Hz power supply is operational and its output is being supplied to the switching relay.
  - Power Light— Illuminates when main power switch is on and the fuse is good. Switch and fuse are both located in the power entry module on the back of the analyzer.
  - On-Line Light—Illuminates when ionizing voltage is applied to the analytical cell. The analyzer requires a sample flow of at least 0.2 cfh (100 ccpm) for the analytical cell to come on line.
  - Low Flow Light— Illuminates when flow to the analyzer is less than 0.2 cfh (100 ccpm). When this occurs the ON-LINE light will be off indicating that no ionizing voltage is being applied to the analytical cell.
  - Overrange Alarm Light— Illuminates when discharge brightness deteriorates due to an unusually high level of impurity in the sample gas.

**CAUTION:** THE DISPLAY METER INDICATES A LOW LEVEL IMPURITY ANALYSIS WHILE IN THIS MODE. THIS IS NOT THE ACTUAL NITROGEN CONCENTRATION.



- **Range Switch:** Used to select the measurement range maximum ppm.
- **Digital Panel Meter (DPM)** — Displays the nitrogen content of the sample stream in ppm.

*Note: When there is no sample flow or there is a loss of ionization voltage, or when the impurities are out of range (i.e. , > 2 ppm in the 2 range, > 20 ppm in the 20 range, and > 200 ppm in the 200 range), the DPM displays "1" (the number one with a decimal point and no additional digits). The maximum number the meter reads before it goes to "1" is 1.999 in the 2 ppm range, 19.99 in the 20 ppm range, or 199.99 in the 200 ppm range.*

- **Zero Potentiometer:** Used for calibration with zero gas.
- **Span Potentiometer:** Used for calibration with span gas.
- **Sample Flow Rotameter:** Monitors flow rate of gas to the analytical cell.

## 1.5 Rear Panel

Connections and other controls are located on the rear panel of the analyzer, as shown in Figure 1-2. This includes:

- **Power Entry Module** — Main power on/off function, connector for input power cable, and fuse holder for the analyzer. This module protects the analyzer from input power surges and the power supply from short circuits.
- **Sample Input Port** — 1/4-in (0.64 cm) VCR fitting marked INPUT. This fitting is used to connect the sample inlet line to the analyzer.



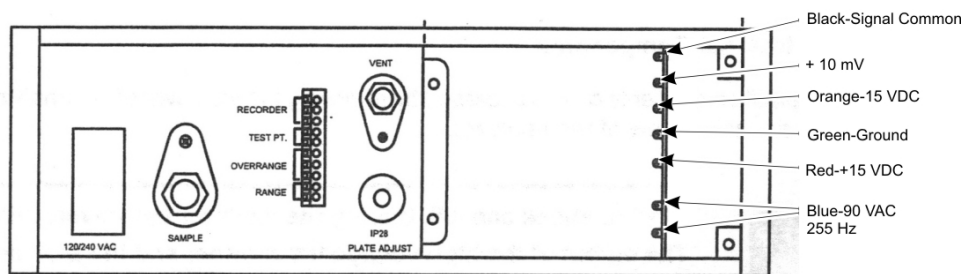

Figure 1-2: Model 2120 Rear Panel

- **Recorder Contacts** — A standard barrier terminal connection is installed for connecting a recorder or other external meter to the analyzer.
- **Test Point Contacts** — Provides an mVDC output signal connector for a DC multimeter and is used during calibration.
- **Ovrrange Alarm Contacts\*** — Normally open and normally closed dry contacts for indication of impurities at levels too high for analyzer's range of detection. Rated for 0.5 A at 30 VAC.
- **Range Identification Contacts\*** — These contacts are closed when the lower range is selected on the front panel of the analyzer and open for the high range. Rated for 2 A at 30 VAC.
- **Sample Vent Port** — 1/4-in (0.64 cm) Swagelok compression fitting marked VENT. Used to connect the sample outlet line to the vent system.
- **1 P28 Plate Adjustment** — A 10-turn, 10 K variable plate voltage adjustment for the high voltage applied to the plates of the PMT by the high-voltage DC power supply.
- **Identification Plate** — This plate identifies the model #, serial #, range, etc.
- **Test Points** — Test jacks are installed to test the voltage outputs of the amplifier board, the low-voltage power supply, and the 255 Hz power supply.

*\*Note: A fuse must be used for any circuit attached to the overrange alarm or range indication contacts.*

## 1.6 Internal Components

The internal components can be accessed by removing the top cover of the analyzer. Figure 1-3 shows an inside view of the analyzer and identifies specific components of the analyzer. See also Figure 1-4 for internal components inside the card cage.

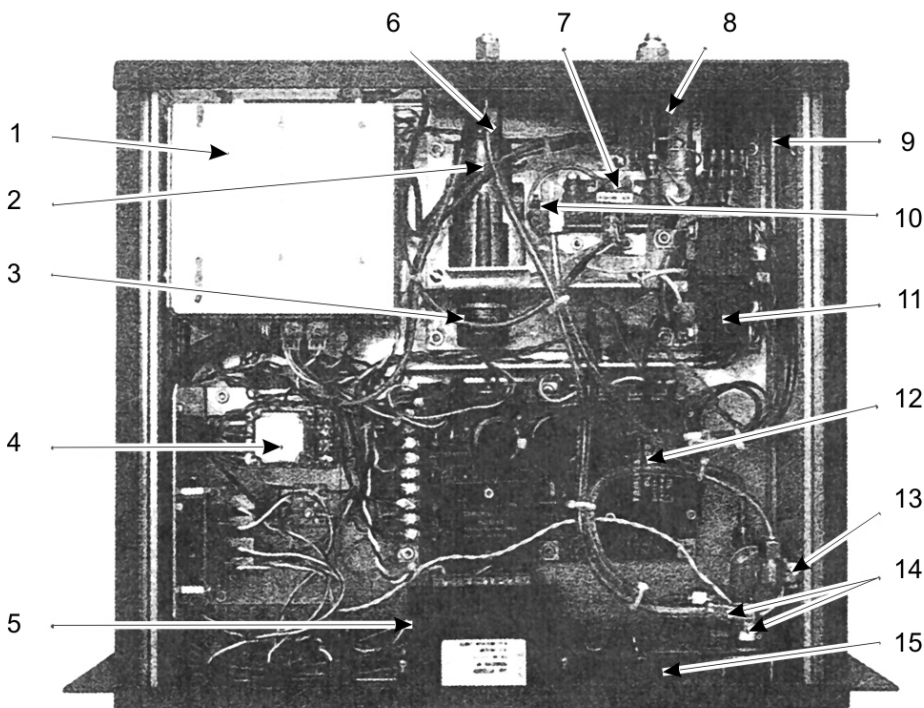

*Figure 1-3: Internal Component Identification*

**WARNING:**



**HIGH VOLTAGE. ELECTROCUTION HAZARD. UNPLUG THE ANALYZER BEFORE REMOVING THE COVER. THE OUTPUT OF THE HIGH-VOLTAGE TRANSFORMER AND THE ANALYTICAL CELL ELECTRODES CAN APPROACH VOLTAGES OF 10,000 VAC. THE ANALYZER SHOULD BE SERVICED ONLY BY A QUALIFIED SERVICE TECHNICIAN.**

The following list is keyed to Figure 1-3 and serves to identify and briefly describe the function of various internal components of the Model 2120 analyzer.

1. **Card Cage for PCB's** — Contains the amplifier board, 4-20 mA conversion board, test point jacks. The interface board is on rear of cage.
2. **PMT Cover** — Shields the PMT for noise reduction and protects it from atmospheric impurities.
3. **Hamamatsu PMT Socket** — The socket contains the high voltage supply for the PMT, the resistor ladder for the intermediate dynodes in the PMT, and a 1.22 VDC reference voltage generator.
4. **Control Relay** — Controls the high voltage transformer.
5. **Digital Panel Meter** — Displays the nitrogen content of the sample stream in parts-per-million (ppm).
6. **Sample Vent Port** — 1/4-in (0.64-cm) Swagelok compression fitting marked VENT. Used to connect the sample outlet line to the vent system.
7. **Analytical Cell** — Cell through which an argon sample stream passes at flow rate.
8. **Sample Input Port With Flow Control Orifice** — 1/4-in (0.64-cm) VCR fitting marked INPUT Used to connect the sample inlet line to the analyzer. Sample flow is controlled by an internal orifice at this input.
9. **Power Entry Module** — Main power on/off function, connector for input power cable, and fuse holder for the analyzer. Protects analyzer from input power surges and power supply from shorts.
10. **Optical Filter** — Optically filters for wavelength of impurity emission.
11. **High Voltage Transformer** — Supplies ionization voltage to the analytical cell causing the sample gas to glow. The transformer is powered by the AC line voltage.
12. **Regulated 255-Hz Power Supply** — A crystal-controlled power supply with an adjustable output. The output is set to supply a modulated 90 VAC output to the high voltage transformer to ionize the sample gas in the analytical cell.

13. **Low-Flow Switch** — Works by magnetic levitation. When sample flow drops below the flow switch setpoint, the switch makes and pulls in the double-pole relay.
14. **Rotameter Inlet and Outlet Connections** — 1/4-in (0.64-cm) Swagelok compression fittings used to connect the sampling lines to the rotameter.
15. **Zero and Span Potentiometers** — Used for calibration with zero and span gas.
16. **Test Jack Panel** — Used to check the 255 Hz power supply, the +15 and -15 VDC power supply, and the 0-10 mV input to the 4-20 mA output module.
17. **4 - 20 mA Module** — Provides a fully isolated DC output in proportion to impurity level.
18. **Amplifier Board** — Conditions the electrical impurity signal from the PMT and contains overrange alarm circuit.

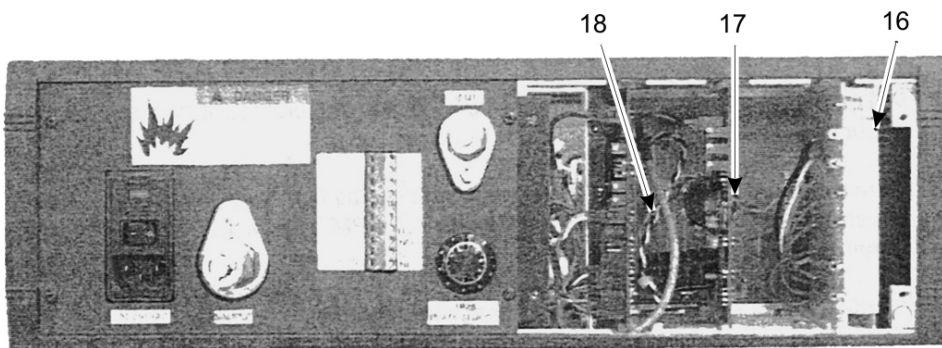

Figure 1-4: Internal Components in Card Cage

## 1.7 Additional Safety Information

*Note: The material provided in this section contains information to promote safety in the operation and maintenance of this equipment. It is not intended to supersede, replicate, or replace any safety documentation or procedures provided from or established by official safety sources.*

**Do NOT operate the Model 2120 Trace Nitrogen in Argon Gas Analyzer until you read and understand the operating,**

**maintenance, and safety instructions included in this manual.**

Anyone involved with the operation of this equipment including plant engineering, operations, and management, must understand the potential hazards involved, and know and observe all required safety precautions.

Your safety and the safety of equipment, nearby facilities, and personnel require a proper safety attitude and emphasis on safe work procedures. This is the essence of any good safety program. If at any time you identify safety deficiencies, immediately correct them and bring them to the attention of management.

Before an accident can be prevented, it must be anticipated. Use pre-job discussions with your coworkers and supervisors to identify hazards and the means to avoid them. At your facility, various gases may exist in liquid and/or gaseous states. Familiarize yourself with the hazards associated with each gas found at your facility.

Read and understand the Material Safety Data Sheets (MSDS) for the materials used with this equipment. All personnel who work in the vicinity of this equipment should read, understand, and follow all safety information contained in the MSDSs, in addition to following all government and facility safety regulations.

**CAUTION:**  **NEVER INTRODUCE GASES OTHER THAN ARGON INTO THE ANALYZER. IF EXPLOSIVE, FLAMMABLE, OR CORROSIVE GASES OR GAS MIXTURES ARE ALLOWED TO FLOW INTO THE ANALYZER, FIRE OR EXPLOSION CAN RESULT. THIS ANALYZER IS NOT DESIGNED TO BE USED IN HAZARDOUS AREAS.**

**1.7.1 Emergency Procedures**

This analyzer is designed to operate safely, efficiently, and reliably. However, as with any analytical equipment involving gases, an emergency can occur at any time. The emergency response could involve calling for medical assistance, management notification, fire assistance, or evacuation from the vicinity of the analyzer. Obtain the following phone numbers and post them at the site telephone locations. Periodically review the numbers and update them as required.

Ambulance: \_\_\_\_\_  
Fire Department: \_\_\_\_\_  
Sheriff or Police Department: \_\_\_\_\_  
On-Site Operations Representative: \_\_\_\_\_

Training and education are the most important parts of any safety program. For every possible emergency, establish an Emergency Response Plan and maintain it for immediate use.

### **1.7.2 Basic Safety Requirements**

The following safety guidelines apply at all times when working with the Model 2120 analyzer:

Prevent electrical shock — Unplug and remove the AC power cord from the rear panel before opening and working on the analyzer. Use tools designed for work on electrical equipment.

Prevent injury — Always wear safety glasses and appropriate safety protection. Ensure that all tools and instruments used during installation and maintenance are in good condition. Be aware that high-velocity gas may be released at vents and safety relief valves.

Follow posted precautions — Read all precautionary labels attached to the equipment. Be sure to read all cylinder labels and warnings. Comply with all precautions before handling the equipment.

Situations may develop for which no written procedures exist. Think carefully before acting. Know the function of each valve and switch, and its effect on the equipment. Carefully review all operating procedures before starting up this equipment to ensure knowledge and understanding.

### **1.7.3 Precautionary Labels**

**WARNING:** TO AVOID SERIOUS INJURY, READ ALL PRECAUTIONARY LABELS ATTACHED TO EQUIPMENT, CYLINDERS, CONTAINERS, AND BOXES PRIOR TO START-UP.



Labels attached in appropriate areas of the analyzer warn you of inherent hazards associated with the system. For personal safety, read the labels and perform directed instructions before handling the equipment.

### 1.7.4 Summary of Known Hazards

This equipment is designed to minimize your exposure to the process gases and other known hazards. Read and thoroughly understand all safety aspects of this system and its operation before operating or maintaining the equipment.

#### 1.7.4.1 ELECTROCUTION

**WARNING:**  **DO NOT OPERATE THE ANALYZER WITHOUT THE COVER SECURED IN PLACE. THE OUTPUT OF THE HIGH-VOLTAGE TRANSFORMER AND THE ANALYTICAL CELL ELECTRODES CAN APPROACH VOLTAGES OF 6,000 VAC OR HIGHER. TO GUARD AGAINST ELECTRICAL SHOCK AND POSSIBLE ELECTROCUTION, THE ANALYZER SHOULD BE SERVICED ONLY BY A QUALIFIED SERVICE TECHNICIAN.**

Adherence to the following guidelines helps guard against electrical shock:

- For safety and proper performance, this analyzer must be connected to a properly grounded three-wire source of electrical power.
- Tampering or unauthorized substitution of components may adversely affect the safety of this instrument. Use only factory-approved components for repair.
- Before checking or replacing any chassis component, turn off the power and remove the AC power cord from the rear panel.

#### 1.7.4.2 PRESSURE

**WARNING:**  **MISHANDLING OF GAS CYLINDERS COULD RESULT IN DEATH, SERIOUS INJURY, OR PROPERTY DAMAGE. HANDLE AND STORE GAS CYLINDERS WITH EXTREME CARE AND IN ACCORDANCE WITH MANUFACTURER'S INSTRUCTIONS.**

Sudden or uncontrolled release of pressurized gas can cause serious injury. The hazards of high pressure can be avoided through careful inspection and handling of cylinders and equipment with proper regulation. Read and understand the MSDSs for the process gases used before operating this analyzer. More detailed information on the precautions and safe practices to follow when handling cylinders can be found in the CGA pamphlet P-1, *Safe Handling of Compressed Gases in Cylinders*.

#### 1.7.4.3 PURGING

**CAUTION:**



**EQUIPMENT DAMAGE MAY RESULT IF THE ANALYTICAL CELL IN THIS UNIT IS EXPOSED TO EXCESSIVE PRESSURE, CAUSING IT TO BREAK OR SHATTER. TO PREVENT THIS, NEVER EXCEED 6 PSIG (41 KPA) ON THE ANALYTICAL CELL.**

**DO NOT REMOVE THE FLOW CONTROL ORIFICE FROM THE SAMPLE INLET OF THE ANALYZER.**

**DO NOT EXCEED 10 PSIG (69 KPA) AT THE SAMPLE INLET.**

**DO NOT BLOCK THE VENT.**

A flow control orifice at the analyzer sample inlet regulates flow and pressure to the analytical cell. With the orifice in place, a maximum inlet pressure of 10 psig (69 kPa) is allowable.

Follow applicable safety precautions to ensure that an oxygen-deficient atmosphere is not created in the work area. Use low parts per million (ppm) nitrogen in argon gas with proper regulation to avoid contaminating the sampling system.

#### 1.7.4.4 SAFE REPAIR PROCEDURES

Any repair work must be performed by a qualified service technician. Use only factory-approved components for repair.

Analyzer manifold purging as well as subsequent repair work must be performed by experienced personnel.

Ventilate working area to prevent any leaking supply gas from accumulating. Vent all gases to the outside.



Vent all pressure relief valves out of enclosed areas. Piping must be properly sized to allow safety devices to operate according to specifications.

De-pressurize supply gas piping before working on it.

#### **1.7.4.5 GENERAL PRECAUTIONS FOR HANDLING AND STORING HIGH PRESSURE GAS CYLINDERS**

Compressed gases have properties that can cause serious accidents, injuries, and even death if proper precautions and safety practices are not followed. Therefore, during handling and use of these gases, be certain to use applicable safety precautions described by your local compressed gas supplier, the Compressed Gas Association, and/or OSHA regulations.

1. Read the label on all cylinders BEFORE using to identify the cylinder contents. If the label is illegible, return the cylinder to the supplier. **DO NOT ASSUME THE CONTENTS.**
2. Secure cylinders in storage and in use to an immovable structure to prevent accidental falling or movement. Read the relevant safety codes.
3. Store or move cylinders **ONLY** in the vertical position. **DO NOT** move or transport cylinders with regulators attached.
4. Store cylinders in a well ventilated area away from heat or ignition sources.
5. When installing tubing, provide **ONLY** approved, adequate pressure reducing regulators and pressure relief devices to prevent over-pressurizing of tubing and equipment.
6. Never drop cylinders or permit them to strike each other violently.
7. Cylinders may be stored in the open but, in such cases, should be protected against extremes of weather and from damp ground (to prevent rusting) in areas where extreme temperatures are prevalent, store cylinders in the shade.
8. The valve protection cap should be left on each cylinder until cylinder has been secured against a wall or bench, or placed in a cylinder stand and is ready for use.
9. Avoid dragging, rolling or sliding cylinders even for a short distance. Move cylinders by using a suitable hand truck.

10. Never tamper with safety devices in valves or cylinders.
11. Do not store full and empty cylinders together. Serious suck-back can occur when an empty cylinder is attached to a pressurized system.
12. No part of a cylinder should be subjected to a temperature higher than 52°C (125°F). Do not permit flame to come in contact with any part of a compressed gas cylinder.



## Operational Theory

---

### 2.1 The Analyzer

The Model 2120 Trace Nitrogen in Argon Gas Analyzer is a rack mountable self-contained unit for measuring trace amounts of nitrogen in an argon gas stream.

A customer supplied sample system directs a stream of refined argon to the instrument at a pressure between 2 and 7 psig (14-48 kPa). The process stream enters at a constant flow rate and passes through a glass analytical cell to which metal electrodes are attached. The electrodes are connected across a high-voltage transformer that provides a silent electrical discharge to ionize the gas in the cell, causing it to glow. A high-voltage transformer takes the signal from a 255 Hz power supply and steps it up to the high-voltage ionization level at 255 Hz. The gas ionizes on both halves of the voltage cycle producing an output frequency of 510 Hz. If nitrogen is present, it adds to the spectrum of light generated. This light is optically filtered so that only a single emission line in the nitrogen spectrum is visible. The resultant light is detected by a photomultiplier. The intensity of the emitted light is proportional to the nitrogen content in the argon gas stream. Figure 2-1 is a block diagram illustrating the general operational principle.

A Hamamatsu high-voltage socket is used for the photomultiplier tube (PMT). It contains the resistor ladder for the intermediate dynodes in the PMT and a 1.22 VDC reference voltage generator. The socket works with a potentiometer, labeled "1 P28 Plate Adjust" on the back of the analyzer, to provide proper plate voltage to the PMT. See Figure 1-2.

The signal from the photomultiplier tube is processed in the amplifier board. The amplifier compensates for the selected measurement range. It filters out line frequency interference and demodulates the signal then converts it to a 0-10 mV output to drive the digital panel meter and the 4 - 20 mA output module.

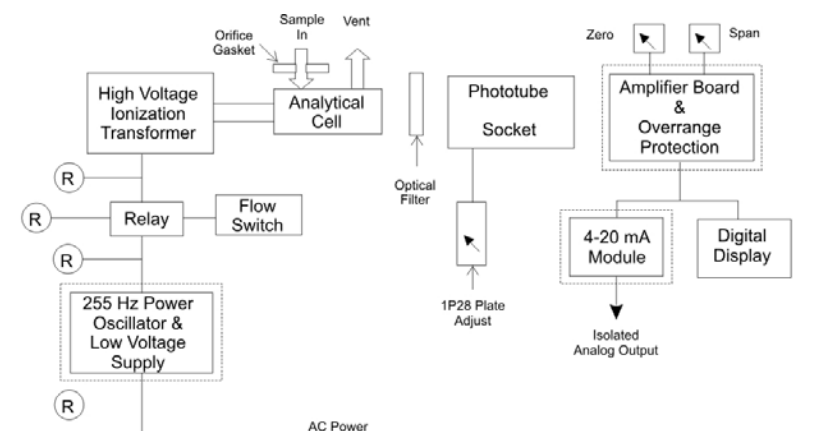

Figure 2-1 Block Diagram for the Model 2120 Analyzer

## 2.2 Overrange Protection

If nitrogen content approaches 1000 ppm, the overall content of light from the plasma discharge decreases considerably. At about 2 percent nitrogen, the ionization is completely extinguished. This effect causes the PMT output to decrease; resulting in a signal that looks like no nitrogen is present in the argon sample, when in fact the content is greater than 1000 ppm.

At the heart of the Overrange Protection Circuit in the Model 2120 is a photodiode that detects the ionization glow and generates a warning when the intensity of the emission signal is low. It is set to trip the warning alarm when the nitrogen concentration reaches the 1000 ppm level. The overrange alarm LED on the front panel turns on when this alarm is generated.

## 2.3 Sample System

A suitable external sample system must be provided by the customer. The external sample system delivers calibration or sample gas to the analyzer at a suitable pressure. Internally the Model 2120 employs a flow control orifice which provides proper flow through the analyzer when the inlet pressure is maintained between 2 to 7 psig (14-48 kPa). The proper flow rate should be maintained around 2 cfh (940 ccpm).

**CAUTION:**

**IT IS THE RESPONSIBILITY OF THE END-USER TO PROVIDE A SUITABLE SAMPLE SYSTEM CAPABLE OF DELIVERING CLEAN, PARTICULATE-FREE ARGON THAT IS AIR AND MOISTURE FREE.**

**EQUIPMENT DAMAGE MAY RESULT IF THE ANALYTICAL CELL IN THIS UNIT IS EXPOSED TO EXCESSIVE PRESSURE, CAUSING IT TO BREAK OR SHATTER. TO PREVENT THIS, NEVER EXCEED 6 PSIG (41 KPA) ON THE ANALYTICAL CELL.**

**DO NOT REMOVE THE FLOW CONTROL ORIFICE FROM THE SAMPLE INLET OF THE ANALYZER.**

**DO NOT EXCEED 10 PSIG (69 KPA) AT THE SAMPLE INLET.**

**DO NOT BLOCK THE VENT.**

The external sample system should be capable of supplying clean, particulate-free and moisture-free sample gas that is also free of air and moisture. If air or moisture are ionized in the analytical cell, ozone emissions are possible. These same conditions apply to any calibration gases used.

Section 3.5.1 provides more information on a suitable sample system.



## Installation

---

Installation of the Model 2120 Trace Nitrogen in Argon Analyzer can involve potentially hazardous procedures.

**CAUTION:**  **INSTALLATION SHOULD BE PERFORMED ONLY BY TRAINED AND QUALIFIED PERSONNEL WHO HAVE READ AND UNDERSTOOD THE INSTRUCTIONS IN THIS MANUAL.**

Installation of the Model 2120 Trace Nitrogen in Argon Analyzer includes:

- Unpacking
- Choosing an Appropriate Location
- Mounting
- Electrical connections
- Gas connections
- Purging
- Calibration

### 3.1 Unpacking the Instrument

The analyzer is shipped with all the materials you need to install and prepare the system for operation. Carefully remove the analyzer from the shipping container and visually inspect it for damage. Maintain it in an upright position and avoid jarring. Ensure the power cord and calibration data sheets are included and that all components ordered have been supplied.

If any items are missing or the analyzer appears damaged, immediately report any damage to the shipping agent and notify Teledyne. Remove and discard caps from fittings; inspect the analyzer for loose fittings or connections.

### 3.2 Choosing a Location

Locate the Model 2120 in a clean area free of:

- Excessive dust
- Mechanical vibrations
- Strong electric or electromagnetic fields
- Corrosive gases
- Moisture exceeding 90% relative humidity
- The use of walkie-talkies or cellular phones

Choose a location where sudden temperature changes in excess of 5°F (5°C) do not occur and where the temperature does not exceed the specified ambient temperature range. Avoid any location where the instrument would be exposed to direct sunlight or radiation from heaters.

**CAUTION:** THIS ANALYZER IS DESIGNED FOR USE IN A  
GENERAL PURPOSE AREA AND IS NOT RATED  
FOR USE IN HAZARDOUS AREAS.



### 3.3 Mounting

The Model 2120 is a rack mountable unit intended for indoor use only. Space and materials required for mounting are:

- 5-1/4-inches (13.3 cm) of 19-inch rack space, as shown in Figure 3-1.
- Service access space behind and in front of the analyzer.
- Metal bracket to support the rear side of the cabinet if the analyzer is installed in a cabinet without side support brackets.
- Eight mounting screws suited to the rack.

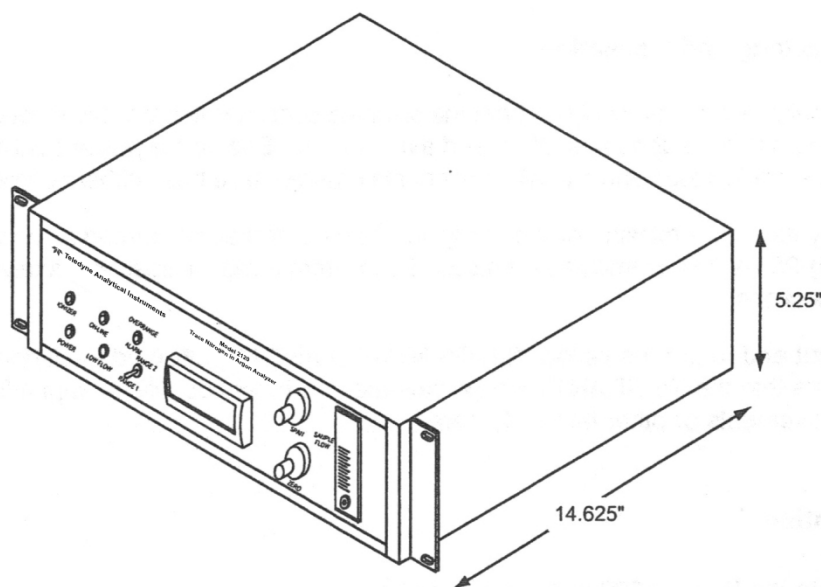

Figure 3-1: Analyzer Dimensions

### 3.4 Electrical Connections

Electrical Connections are made at the rear of the instrument. See Figure 3-2.

Materials required:

- Power Cord
- Fuse(s) for Power Entry Module, if it is not configured for the power supply available. If necessary, refer to Section 5.4.1 for voltage selection and fuse changing instructions.

Electrical connections to the instrument are made as follows:

1. Ensure the Power Entry Module is set for the proper line voltage and contains the correct fuses. See Section 5.4.1.
2. Ensure that the Power Switch located on the rear of the analyzer is in the OFF position.
3. Connect the AC power cord to the proper line voltage. This voltage must be stable, transient free, and have a stable frequency for optimum operation. Also, the unit must be properly grounded.

- Connect the 4-20 mA analog recorder output terminals to a recorder, if desired. The recorder output terminals are located on the terminal strip on the back of the analyzer as shown in Figure 3-2.

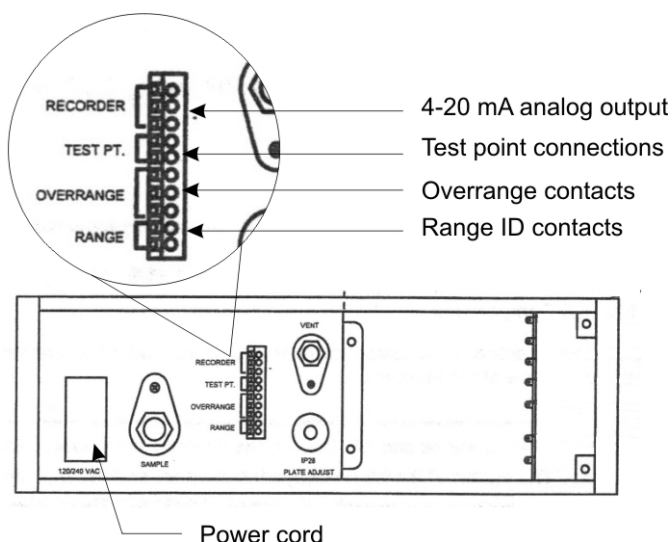

Figure 3-2: Electrical Connections

### 3.5 Gas Connections

**CAUTION:** THIS INSTRUMENT IS NOT DESIGNED TO HANDLE HAZARDOUS GASES.



OZONE EMISSIONS CAN OCCUR IF AIR OR MOISTURE ARE IONIZED IN THE SAMPLING SYSTEM. THE SAMPLE PATH MUST BE RELATIVELY FREE OF AIR AND/OR MOISTURE BEFORE APPLYING THE IONIZING VOLTAGE.

KEEP THE SERIES 1200 POWER OFF UNTIL THE ANALYZER IS FULLY PURGED.

*Note:* Air leaking into the sampling system will cause erratic or unsatisfactory analyzer operation. Even if air is admitted into the system for only a few minutes, you must purge the regulator and the system for at least 1 hour before the readings stabilize. See Section 3.6.

Whenever a fitting on the sample system is opened, use a new ferrule and cone or new gasket depending on the type of fitting to secure a gas tight seal. Each fitting should be leak checked whenever a connection has been opened or disturbed in any manner.

### 3.5.1 Typical Sample System

A suggested sample system is shown in Figure 3-3. This system allows you to switch the analyzer between zero or span calibrating gases and the process gas streams quickly and efficiently without disconnecting the analyzer and introducing air in the system.

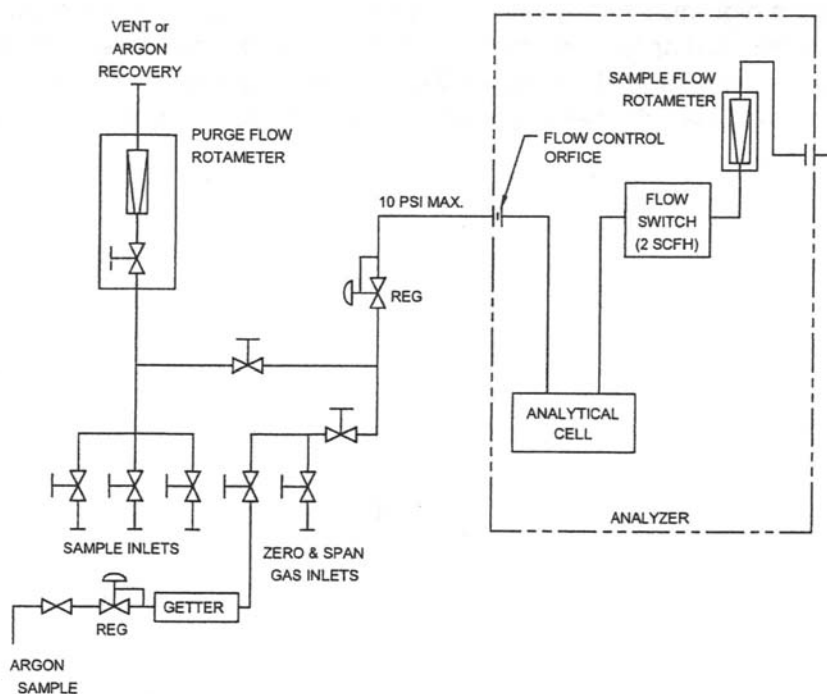

Figure 3-3: Suggested Sample System

The sample manifold system must be designed so that you can:

- Purge the sample line and pre-adjust the flow rate before admitting a sample to the analytical cell.
- Maintain a flow of argon through the analytical cell whenever ionization voltage is being applied.

The following guidelines are presented as an aid in constructing a suitable external sampling system for the Model 2120:

- Alter the geometry of the system in Figure 3-2, as necessary, to suit your specific needs and to maintain access to items on the rear panel. However, alterations should be adhered to schematically.
- Use 1/8-inch (0.32 cm) electro polished stainless steel tubing for all parts of the manifold between the source and sample inlet connections of the analyzer. Although you can use 1/4-inch (0.64 cm) tubing, it is not recommended. The manifold should be a welded assembly wherever possible.
- Use only high-purity components with metal seals.
- Eliminate excess components.
- Minimize "dead spaces" in the sample lines.
- Use a 1/4-inch (0.64 cm) VCR fitting for the analyzer inlet connection. 1/4-in VCR glands with 1/8 in tube stubs are available.
- Use a high-quality regulator or device to maintain a constant pressure to the zero, sample, and span inlet lines. Teledyne recommends using a high-purity regulator with the following specifications:
  - 2-stage tied diaphragm
  - 100 psi outlet
  - 15 RA max
  - 5 ports
  - CGA 580 welded on inlet side
  - 1/4 MVCR (1 port), 1/4 FVCR (1 port)
  - 2 gauges



### 3.5.2 Gas Connections to the Instrument

**CAUTION:** EQUIPMENT DAMAGE MAY RESULT IF THE ANALYTICAL CELL IN THIS UNIT IS EXPOSED TO EXCESSIVE PRESSURE, CAUSING IT TO BREAK OR SHATTER. TO PREVENT THIS, NEVER EXCEED 6 PSIG (41 KPA) ON THE ANALYTICAL CELL.

**DO NOT REMOVE THE FLOW CONTROL ORIFICE FROM THE SAMPLE INLET OF THE ANALYZER.**

**DO NOT EXCEED 10 PSIG (69 KPA) ON THE SAMPLE INLET.**

**DO NOT BLOCK THE VENT.**

To connect the gas line:

1. Connect an unobstructed vent line to the 1/4-in (0.64 cm) Swagelok fitting on the vent port on the rear of the analyzer.
2. Connect the inlet line from the sample manifold system, regulated to 6 psig (41 kPa), to the 1/4-in (0.64 cm) VCR Input port fitting on the rear of the analyzer.

### 3.6 Purging

The Model 2120 is equipped with a flow control orifice installed at the analyzer sample inlet to regulate flow and pressure to the analytical cell. With the orifice in place, a maximum inlet pressure of 10 psig (69 kPa) is allowable.

**CAUTION:**  **OZONE EMISSIONS ARE POSSIBLE IF AIR OR MOISTURE IS IONIZED IN THE SAMPLING SYSTEM. THE SAMPLE PATH MUST BE RELATIVELY FREE OF AIR AND/OR MOISTURE BEFORE APPLYING THE IONIZING VOLTAGE.**

**KEEP SERIES1200 POWER OFF UNTIL THE ANALYZER IS FULLY PURGED.**

When installing a new analyzer or starting up an analyzer that has been idle for a period of time, the sampling system should be purged for several hours to cleanse it of contaminants and water vapor.

Materials required:

- Purge gas: A high-purity sample gas may be used to purge. Argon with a minimum purity of 99.999% should be used.

The exact purge method depends on the sample manifold design and construction. In general, each sample inlet line must be thoroughly purged. Sufficient purge time becomes critical when sample lines longer than 10 feet (3 m) are used.

To purge the analyzer (see Figure 3-2):

*Note: Do not purge long lines through the analytical cell. First, purge them through the purge flow rotameter; then transfer flow to the analyzer cell as suggested in step 6, below. This eliminates the possibility of contaminating the analytical cell and having to purge for an extended period to reach equilibrium.*

1. Close all valves on the sample manifold.
2. Open the valve on sample inlet line to be purged and the purge rotameter valve.
3. Connect purge gas to the sample inlet line.
4. Adjust flow rate to 1 cfh (0.475 slpm) at no more than 7 psig (76 kPa), as indicated on the purge rotameter, and purge for at least one hour.
5. Close the sample inlet valve, and then repeat steps 2 through 4 to purge all other sample inlet lines.
6. After the last sample line and the zero and span gas inlet lines have been purged, close the purge rotameter valve, open the valve controlling flow through the analytical cell, and purge the analyzer with the sample flow rotameter set at 1 cfh (0.475 slpm). Purge the analyzer for a minimum of 6 hours.
7. If cylinder argon is used as a purge gas, reconnect the sample gas to sample manifold inlet.

### 3.7 Calibration

The Model 2120 was calibrated at the factory in accordance with the calibration data shipped with your instrument. Prior to using the instrument for analysis the calibration must be checked using the factory

settings supplied. If the settings do not match, the instrument should be recalibrated prior to using for the first time.

Calibration procedures require an understanding of how to operate the instrument which is discussed in Section 4 of this manual. Refer to Section 4.2 for calibration procedures after reading the entire section on operating the instrument (Section 4).

### 3.8 Installation Checklist

After installing the system, and prior to powering up the system, verify the following items:

1. Each gas line has been purged for at least 1 hour prior to connection to the analyzer inlets.
2. There are no leaks at the sample inlet gas connection to the instrument.
3. There are no leaks between the span gas cylinder and the analyzer span gas inlet port when span gas is flowing to the analyzer.
4. There are no leaks between the zero gas source and the analyzer zero gas inlet port when zero gas is flowing to the analyzer.
5. The vent tube connection has no leaks, has an unobstructed path to atmosphere, and is at least 1/4-in (0.64-cm) OD.
6. All electrical connections have been made properly and the Power Entry module is set for the appropriate power from your facility.



## Operation

---

This section describes the operation and calibration procedures for the Model 2120 Trace Nitrogen in Argon Analyzer. Operation of the analyzer involves potentially hazardous procedures. Only trained and qualified personnel who have read and understood the instructions in this manual should operate this equipment.

**CAUTION:**  **DO NOT OPERATE THIS ANALYZER UNTIL YOU HAVE READ AND UNDERSTOOD THE INSTRUCTIONS IN THIS MANUAL. PAY PARTICULAR ATTENTION TO ALL CAUTIONS AND WARNINGS.**

**NEVER INTRODUCE GASES OTHER THAN ARGON INTO THE ANALYZER IF EXPLOSIVE, FLAMMABLE, OR CORROSIVE GASES OR GAS MIXTURES ARE ALLOWED TO FLOW INTO THE ANALYZER, FIRE OR EXPLOSION CAN RESULT.**

**THIS ANALYZER IS NOT DESIGNED FOR USE IN HAZARDOUS AREAS.**

**EQUIPMENT DAMAGE MAY RESULT IF THE ANALYTICAL CELL IN THIS UNIT IS EXPOSED TO EXCESSIVE PRESSURE, CAUSING IT TO BREAK OR SHATTER. TO PREVENT THIS, NEVER EXCEED 6 PSIG (41 KPA) ON THE ANALYTICAL CELL.**

**DO NOT REMOVE THE FLOW CONTROL ORIFICE FROM THE SAMPLE INLET OF THE ANALYZER.**

**DO NOT EXCEED 10 PSIG (69 KPA) AT THE SAMPLE INLET. DO NOT BLOCK VENT.**

*Note: Maintain a 1 cfh (0.475 slpm) flow of sample gas through the analyzer when it is not in use. This procedure is highly recommended in areas of high humidity. Take care to keep the inside of the instrument dry.*

## 4.1 Powering Up the Analyzer

**CAUTION:**  **OZONE EMISSIONS ARE POSSIBLE IF AIR OR MOISTURE ARE IONIZED IN THE SAMPLING SYSTEM. THE SAMPLE PATH MUST BE RELATIVELY FREE OF AIR AND/OR MOISTURE BEFORE APPLYING THE IONIZING VOLTAGE.**

**KEEP THE POWER OFF UNTIL THE ANALYZER IS FULLY PURGED.**

The Range switch on the front of the analyzer should be toggled to the desired measurement range prior to power-up and calibration.

*Note: When changing measurement ranges, recalibration is necessary.*

1. Purge the analyzer and sampling system using the procedure described in Section 3.6.
2. Turn on the analyzer by pushing the Power Switch on the power entry module on the rear panel to the ON position. The power light on the front panel will illuminate.
3. Sample flow is regulated by an orifice in the sample inlet connection, As the flow rate into the analyzer increases beyond approximately 1.0 cfh (470 ccpm), the on-line light illuminates. This indicates that the flow switch is operating correctly.

**CAUTION:**  **EQUIPMENT DAMAGE MAY RESULT IF THE ANALYTICAL CELL IN THIS UNIT IS EXPOSED TO EXCESSIVE PRESSURE, CAUSING IT TO BREAK OR SHATTER.**

**DO NOT REMOVE THE FLOW CONTROL ORIFICE FROM THE SAMPLE INLET OF THE ANALYZER.**

4. Observe the digital panel meter while allowing the instrument to warm up and the readings stabilize. Drift occurs until internal temperatures stabilize and the analytical cell is completely purged. A persistent drift indicates an improperly purged system or an air leak into the system. Refer to Section 5 for suggested corrective procedures.

## 4.2 Zero and Span Calibration

The Model 2120 is designed to provide a linear response over the 0-20/0-200 or the 0-2/0-20 ppm concentration range for nitrogen in argon. Therefore, a two-point (zero and span) calibration is sufficient to define the calibration curve for this analyzer.

Prior to shipment, the analyzer was calibrated by the factory in accordance with the calibration data shipped with your analyzer. Use these settings to verify that the unit is in calibration, or re-calibrate the analyzer as outlined in this section.

### 4.2.1 Before Calibration

*Note: To minimize consumption of zero and span gases, careful attention to the purging of the analyzer, as described in Chapter 3, is critical.*

1. Ensure that the analyzer is fully purged and warmed up.
2. Check to make sure that the low flow light is not illuminated.
3. Check that the sample gas flow rate is 2 cfh (940 ccpm), as indicated on the front panel flowmeter. Adjust sample flow by adjusting the pressure regulator on the sample inlet. **Do not exceed a maximum of 7 psig (76 kPa).**

### 4.2.2 Recommended Calibration Gases

Teledyne recommends the following gases be used for calibration:

*For 0-2 ppm range:* zero gas—N<sub>2</sub>-free Ar  
span gas—1.60 – 2 ppm N<sub>2</sub> in Ar

*For 0-20 ppm range:* zero gas—0 – 2 ppm N<sub>2</sub> in Ar or N<sub>2</sub>-free Ar  
span gas—16 – 20 ppm N<sub>2</sub> in Ar

*For 0-200 ppm range:* zero gas—0 – 2 ppm N<sub>2</sub> in Ar or N<sub>2</sub>-free Ar  
span gas—160 – 200 ppm N<sub>2</sub> in Ar

The first calibration point is fixed by a zero gas. The most convenient source of nitrogen-free argon is through an activated molecular sieve getter cooled to liquid oxygen temperatures or a heated transition metal getter. A commercially available instrument, the GOW-MAC® Model 75-800 Noble Gas Purifier, is ideal for this. A zero gas

cylinder with a low ppm nitrogen level can be used for zeroing in the low ppm range specified, as long as the N<sub>2</sub> concentration is known.

The second point is fixed by a certified span gas normally supplied in a high-pressure cylinder.

#### 4.2.3 Calibration Steps

*Note: The zero, span, and sample gas should all be supplied to the analyzer at the same flow rate, 2 cfh (940 ccpm). The Analyzer flow and pressure are controlled by a sample inlet orifice. Use the regulator at the sample, span, or zero gas source to adjust flow while monitoring the flowmeter on the front panel.*

To calibrate the instrument:

1. Set the ZERO potentiometer to 2.00 and SPAN potentiometer to 8.00. (If zero and span settings from a previous calibration are known, these may be used in place of 2.00 and 8.00.)
2. Connect a DC millivoltmeter across the Test Points on the rear panel.

*Note: To preserve calibration accuracy, cylinder pressure for the calibration standard gases should not fall below 500 psig (3447 kPa).*

3. Flow span calibration gas to the analytical cell at a rate of 2 cfh (940 ccpm) as determined from the sample flowmeter on the front panel.
4. Plate Adjustments:

*For the 0-200 ppm range:* Adjust the plate adjustment potentiometer on the rear panel to obtain a reading in mVDC equal to 0.7 times the span calibration gas in ppm (i.e., with a span gas of 180 ppm, the millivolt reading should be 126 mVDC).

*For the 0-20 ppm range:* Adjust the plate adjustment potentiometer on the rear panel to obtain a reading in mVDC equal to 7 times the span calibration gas in ppm (i.e., with a span gas of 18.0 ppm, the millivolt reading should be 126 mVDC).

*For 0-2 ppm range:* Adjust the plate adjustment potentiometer on the rear panel to obtain a reading in mVDC equal to 70 times the span calibration gas in ppm (i.e., with a span gas of 1.8 ppm, the millivolt reading should be 126 mVDC).

*Note: This is an approximate reading. This initial setting is changed only when some major part of the analyzer is changed or the 1P28 phototube becomes weak with age. Then the plate adjustment control may require additional adjustment to keep the analyzer calibrated.*

5. With span gas flowing at a rate of 2 cfh (940 ccpm), and the output stabilized, adjust the SPAN potentiometer to obtain a reading on the panel meter equal to the span gas in ppm nitrogen.
6. Stop the span gas and start flowing zero calibration gas to the analytical cell at a rate of 2 cfh (940 ccpm). Wait approximately 30 minutes for the digital panel meter reading to stabilize. Adjust the ZERO potentiometer to obtain a reading on the panel meter equal to the zero gas in ppm nitrogen.
7. Repeat steps 5 and 6 until stable zero and span readings are obtained without further adjustments.
8. When calibration is complete, close the span and zero inlet lines, and record the settings of the ZERO, SPAN, and the plate adjustment potentiometers on your equipment calibration log. A sample equipment calibration log is included in the Appendix of this manual for your convenience. Subsequent calibrations modify these settings, and you may find that a record of the changes is useful when troubleshooting analyzer problems.

### 4.3 Reading and Recording Data

**CAUTION:** THE DIGITAL PANEL METER MAY INDICATE A NEGATIVE VALUE OR DISPLAY A CONSTANT "1" WHEN HIGH CONCENTRATIONS OF NITROGEN ( $\geq 0.5$  PERCENT) ARE PRESENT. NO MATTER WHAT THE DIGITAL DISPLAY INDICATES, AN



**OVERRANGE ALARM INDICATES HIGH CONCENTRATIONS OF NITROGEN ( $\geq 0.5$  PERCENT) IN THE SAMPLE LINE.**

On completion of the zero and span calibrations, the Model 2120 is ready to begin taking readings on the sample gas.

1. Open the valve of the desired sample inlet line.
2. Adjust the flow rate to 2 cfh (940 ccpm).
3. If desired, connect a recorder to the recorder output connector on the back panel.
4. To proceed with an analysis of another sample line, close the valve of the current sample line, open the valve of the new sample line, and adjust the flow rate to 2 cfh (940 ccpm).

#### 4.4 Overrange Protection Circuit

The Overrange Protection Circuit has two main parts:

1. A photodiode that provides a signal proportional to the total light intensity from the analytical cell.
2. An alarm that takes action if the photodiode signal falls below a threshold value.

The Overrange Protection Circuit requires no adjustment other than the initial factory calibration. Even if the photodiode output shifts substantially, the Overrange Protection Circuit operates properly. No routine maintenance to this circuit is required, but the following test of the circuit is recommended after each scheduled analyzer calibration.

To test the Overrange Protection Circuit:

1. While the analyzer is running, shut off sample flow. This causes the low flow switch to cut off the high voltage to the analytical cell so that the glow discharge will extinguish. The alarm circuitry should indicate an overrange condition.
2. The following events should take place:
  - a. The red overrange LED turns on and stays on.
  - b. The panel meter reads "1" without any figures after the decimal point.



- c. The recorder output indicates a full-scale signal or slightly higher.
- d. The digital overrange contacts change state (NC to open or NO to closed).

If the above events do not occur, suspect a fault in the Overage Protection Circuit and contact the factory.



## Maintenance

---

**CAUTION:** MAINTENANCE AND REPAIR OF THE MODEL 2120 ANALYZER INVOLVE POTENTIALLY HAZARDOUS PROCEDURES. ONLY TRAINED AND QUALIFIED PERSONNEL WHO HAVE READ AND UNDERSTOOD THE INSTRUCTIONS IN THIS MANUAL SHOULD WORK ON THIS EQUIPMENT.



### 5.1 Routine Maintenance

Aside from normal cleaning and checking for leaks at the gas connections, routine maintenance consists of recalibration and periodic inspection of essential analyzer parts. For calibration procedures, refer to Section 4.2. The periodic inspection of analyzer parts helps ensure continuing high performance and reduces malfunctions that could lead to analyzer downtime.

### 5.2 Routine Maintenance Schedule

Perform a routine calibration of the analyzer at least once every one to two weeks. Keep a log of the percentage zero and percentage span deviation settings. This ensures not only that accuracy is maintained; it also may help in troubleshooting the analyzer if these settings vary widely at each calibration or vary consistently up or down scale. If the readings are stable from calibration to calibration, then the frequency of routine calibrations can be decreased accordingly.

Check the sample and reference gas flow rates at least every one to two weeks. Use the rotameter on the front panel to check that the sample flow rate is approximately 2 cfh (0.9 slpm).

Check for excessive accumulation of dirt. In dusty locations, you may need to wipe or gently blow off dust from the various sections at least once a week. Any accumulation of dust or oil film hinders satisfactory operation.

On an annual basis, check the gas lines for signs of leaks.

Table 5-1 summarizes the recommended routine maintenance required for the Model 2120.

*Table 5-1: Routine Maintenance Schedule*

Maintenance Task	Time Schedule
Calibrate	Every 1-2 weeks
Check sample and reference gas flow rates	Every 1-2 weeks
Check for excessive accumulation of dirt	Weekly
Check gas lines for leaks	Yearly

### 5.3 Troubleshooting

**WARNING:** **HIGH VOLTAGE. ELECTROCUTION HAZARD. NEVER OPERATE THE ANALYZER WITHOUT THE COVER SECURED IN PLACE. DO NOT TAMPER WITH OR TRY TO ADJUST THE ANALYZER UNLESS YOU ARE THOROUGHLY KNOWLEDGEABLE OF THE INSTRUMENT AND ITS OPERATION. ALWAYS TURN OFF POWER AND DISCONNECT THE AC POWER CORD BEFORE SERVICING.**



Intervention should remain limited to the replacement of defective parts.

Before consulting the troubleshooting guide in Table 5-2, ensure that the sample flow is constant and vent pressure is at atmospheric pressure.

Table 5-2 provides you with information on problems that may occur with the Model 2120 Analyzer. Also included are their probable causes and suggested remedies to the problem. Standard hand tools and a digital multimeter are the only equipment required for most procedures.

*Note: If you cannot fix the problem using these guidelines, contact Teledyne Customer Service (626) 961-9221 and be ready to give details regarding your installation, including the analyzer's serial number found on the identification plate located on the back panel.*

*The Model 2120 is manufactured in several models. Determine which model you have before proceeding. The model number is found on the serial number label located on the back of the instrument.*

*Table 5-2: Troubleshooting*

<b>Problem</b>	<b>Probable Cause</b>	<b>Remedies</b>
Loss of power (no lights or DPM).	Fuse or power cord not connected.	Connect power cord or replace fuse.
DPM display is off, fuse is OK, power connected.	Defective DPM.	Check and replace if defective.
Functions erratically.	Power interruption.	Check for proper line voltage.
	Gas not flowing through analyzer at correct rate.	Check that gas flows at 2 cfh (0.9 slpm). Check for flow obstructions or faulty low flow switch.
	Defective regulated power supply.	Check internal power supply at rear panel test point. Replace if defective.
DPM reads -1.00 ppm or flashes.	Loss of sample flow or flow too low.	Check that gas flows at 2 cfh (0.9 slpm). Check for flow obstructions or faulty low flow switch.
	Loss of ionization voltage from transformer.	Check transformer and flow switch. Replace if faulty.
	Defective amplifier board.	Check and replace if faulty.
	Defective 255 Hz power supply board.	Check and replace if faulty.
Recorder off scale (top or bottom).	Improper calibration.	Repeat calibration procedure.
	No voltage or improper voltage to analytical cell.	Check high voltage transformer and flow switch. Replace if faulty.
	Defective 255 Hz power supply.	Check and replace if faulty.

	Defective PMT.	Check and replace if faulty.
	Defective amplifier board.	Check and replace if faulty.
	Defective high-voltage PMT socket.	Check and replace if faulty.
Recorder off scale (top or bottom) - continued	Defective low-voltage DC power supply.	Check and replace power supply if faulty.
	Sample line leakage, improper sampling, etc.	Check sample lines for leak. If a leak is found, re-purge sample lines.
	Defective ZERO or SPAN potentiometer.	Check and replace if faulty.
Recorder drift	Analyzer not warmed up.	If analyzer recently started up, wait for warm-up.
	Sample line leakage.	Check sample lines for leak. If a leak is found, re-purge sample lines.
	Analyzer or sampling system not fully purged.	Purge analyzer and sampling system 12 or more hours or overnight.
	Flow not stable.	Check for flow obstructions or faulty low-flow switch.
	Weak signal.	Check amplifier board and replace if defective.
	Defective recorder.	Check recorder per supplier manual.
	Increase in pressure in analytical cell.	Check for obstructions in sample flow meter, low flow switch, or analyzer tubing (such as water in vent line).  Re-purge the system if an obstruction is found.
Recorder oscillates and readings are erratic.	Improper plate voltage on PMT.	Check and replace if faulty.  Check calibration data supplied with analyzer.

	External electrical interference.	Shield to avoid stray fields caused by large motors or transformers and power lines. Ground shields
	Recorder gain too high.	Check recorder per supplier manual.
	Ionization voltage too high.	Check internal power supply and replace if defective.
	Defective PMT.	Check and replace if faulty.
	Defective amplifier board.	Check and replace if faulty.
No signal or signal is too weak.	Faulty Hamamatsu PMT socket.	Check and replace if faulty.
	Faulty amplifier board.	Check and replace if faulty.
	Faulty low-voltage DC power supply.	Check and replace if faulty.
	Open high-voltage transformer.	Check and replace if faulty.
	Faulty PMT.	Check and replace if faulty.
	Faulty analytical cell.	Check and replace if faulty.
	Dirty optical filter.	Clean the optical filter.

## 5.4 Parts Replacement and Testing Guide

**WARNING:** ELECTROCUTION HAZARD. LETHAL VOLTAGE INSIDE — 6000 VOLTS.



**THIS ANALYZER MUST BE SERVICED ONLY BY A QUALIFIED TECHNICIAN.**

**NEVER OPERATE THE ANALYZER WITHOUT THE COVER SECURED IN PLACE. ALWAYS TURN OFF POWER AND DISCONNECT AC POWER CORD BEFORE SERVICING.**

*Note: The analyzer cover must be removed for access to internal components. To remove the cover, first loosen the front panel from the front of the analyzer. The screws that hold the front panel in place are underneath the protective molding on each side of the front panel (two pieces).*

Refer to Figures 1-3 and 1-4 for component locations while reading this section.

### 5.4.1 Voltage Selection and Fuse Changing

The Model 2120 Trace Nitrogen in Argon Analyzer can be configured for either 110 or 230 VAC line voltage.

Figure 5-1 shows the Power Entry Module with its hinged cover open for access to the fuse cartridge. A small screwdriver can be used to gently pry open the cover from the top of the assembly.

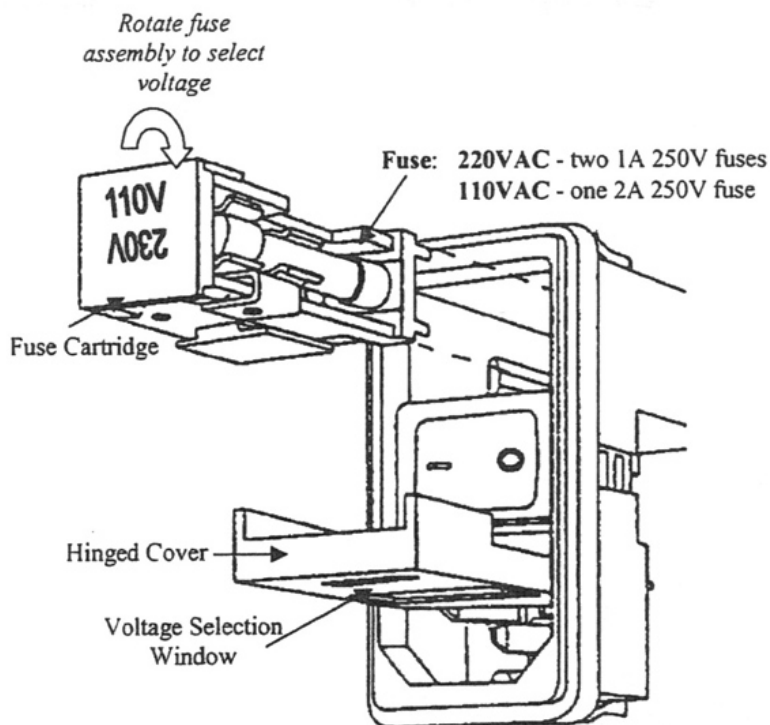



Figure 5-1: Power Entry Module

To change the selected line voltage, follow the steps outlined below while referring to Figure 5-1.

1. Ensure the AC power cord is disconnected from the unit. Then open the hinged cover to the power entry module as described above.
2. Remove the fuse assembly.
3. Check for the proper fuse (2 amp, 250 V fuse for 110 VAC; 1 amp, 250 V fuse for 230 VAC) and replace if necessary.

**CAUTION:**  **EXCESSIVE CURRENT THROUGH THE ANALYZER CAN RESULT IN EQUIPMENT DAMAGE. BE SURE THE PROPER FUSE IS IN PLACE FOR THE SELECTED VOLTAGE BEFORE APPLYING POWER TO THE ANALYZER.**

4. Turn the fuse assembly so that the selected voltage is right side up and shows through the voltage selection window of the power entry module.
5. Replace the fuse cartridge in the power entry module.
6. Close the power entry module hinged cover.
7. Check to see that the proper line voltage displays in the voltage selection window.

#### 5.4.2 Optical Filter

**CAUTION:**  **DO NOT TOUCH THE FACES OF THE OPTICAL FILTER. OIL FROM THE SKIN AFFECTS THE OPTICAL CHARACTERISTICS.**

The optical filter is located beneath the PMT cover. Perform the following steps to clean the filter:

1. Ensure the AC power cord is disconnected from the unit. The optical filter fits into the window opening of the PMT cover and will fall away from the PMT when the cover is removed.
2. Remove the PMT cover and optical filter, carefully catching the optical filter with a gloved hand. One side of the 25-mm diameter filter is dark and the other side is mirror-like. The

filter is installed, mirror-side out, from inside the PMT cover when it is removed from the PMT.

3. Wipe the filter clean with a damp, lint-free cloth. Use only water. Do NOT use detergent.
4. Replace the filter into the window opening with the mirror-side out.
5. Replace the cover on the PMT. Take care to keep the filter and window lined up with the vertical grid visible within the tube. If this is done correctly, the window and filter face the analytical cell when the PMT is keyed into its socket.

### 5.4.3 Low Flow Switch

To test the flow switch operation:

1. With the analyzer running, slowly decrease sample flow. As the flow falls below approximately 75 ccpm, the Low Flow Switch should activate the relay to cut off the ionizing voltage from the transformer. When this happens, the front panel *LOW FLOW* light turns on, and the *IONIZER* light turns off. The *OVERRANGE ALARM* condition is also activated.
2. Slowly increase the sample flow up toward the 2 scfh analyzer flow rate. As the flow increases above approximately 100 ccpm, the switch should activate the control relay to apply ionizing voltage to the analytical cell. When this happens:
  - The control relay switch activates.
  - The front panel *LOW FLOW* light turns off.
  - The *IONIZER* light turns on.
3. If the events listed in steps 1 and 2 do not take place, either the low flow switch or the control relay is not functioning properly. Test the control relay to isolate the problem.

### 5.4.4 Control Relay

To test the relay:

1. Remove the AC power cord from the unit.

2. Apply activating voltage (120 VAC on a 120 V model/ or 230 V on a 230 V model) to the relay coil. If the relay does not activate, it is faulty.

To replace the control relay, perform the following steps:

1. Remove the AC power cord from the unit.
2. Remove the top cover.
3. Remove and replace the control relay.

#### 5.4.5 Analytical Cell

Refer to Figure 5-2.

To remove cell and mounting bracket assembly from analyzer:

1. Remove the AC power cord from the unit.
2. Remove the inlet and outlet tubes (A, B) from the sample system fittings, using care not to torque or pressure the glass cell inlet and vent tubes.
3. Remove the nuts from the four bolts that attach the cell mounting bracket to the mounting plate on the bottom of the analyzer (C).
4. Lift the cell and mounting bracket assembly gently to gain access to the electrode connections (D).
5. Remove the transformer high voltage leads from the electrode connections by gently loosening and removing the nuts that hold them in place.

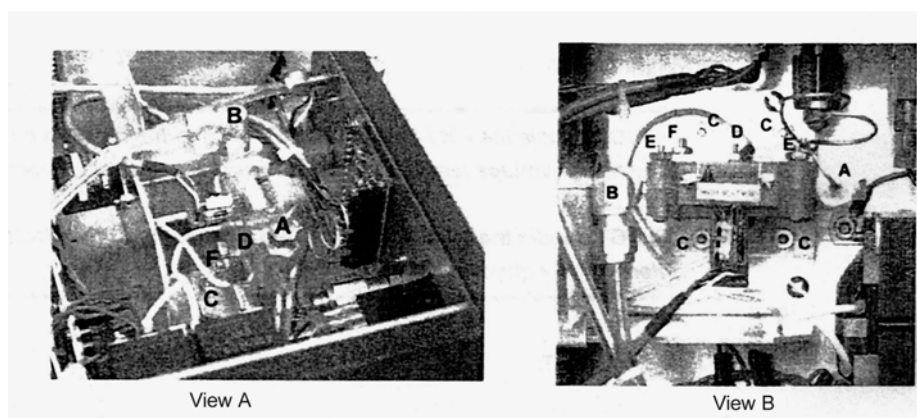

Figure 5-2: The Analytical Cell

To remove the cell from the cell holder:

1. The cell holder has two side plates that hold the cell in place. To loosen the grip of these side plates, remove the four bolts that hold together the plates: two bolts toward the top of the cell assembly (E) and two toward the bottom (F). The bottom bolts go through the mounting bracket as well. **DO NOT REMOVE THE SCREWS ON TOP OF THE CELL HOLDER. THEY HOLD THE OPTICAL SENSOR BOARD ON TOP OF THE CELL IN PLACE.**
2. Open the cell holder assembly from the bottom, letting the top of the assembly (where the optical sensor board and high voltage sticker are placed) act as a hinge. Carefully remove the cell from the cell holder.

To install a new cell:

1. To begin installation of a new cell, first disassemble the cell holder as described above.
2. Slide new cell into the opened cell holder assembly. Re-install the four bolts that hold together the sides of the cell holder. The bottom two bolts must hold the mounting bracket to the cell holder.
3. Securely re-attach high the voltage transformer leads to the electrode connections.
4. Carefully lower the cell assembly into the mounting plate in the bottom of the analyzer, placing it over the bolts that fit into the cell's bracket. Using four nuts and washers, attach the cell assembly to the mounting plate.
5. Carefully install the inlet and outlet fittings on the cell inlet and outlet glass tube stubs.

#### **5.4.6 Photomultiplier Tube**

*Note: DO NOT handle the PMT glass surface with bare hands. Skin oil can create high-voltage leakage paths and affect the optical characteristics.*

*DO NOT handle the optical filter with bare hands. Skin oil affects the filters optical characteristics.*

To replace the PMT:

1. Remove the AC power cord from the unit.
2. When removing the PMT cover, the optical filter dislodges from its position. Remove the PMT cover, carefully catching the optical filter with gloved hands to avoid getting any fingerprints on the filter.
3. Remove the PMT.
4. Install the new PMT.
5. Clean the glass surface of the PMT, removing any fingerprints or dust.
6. Replace the optical filter into the window opening with the mirror-side out. Hold it in place.
7. Replace the cover on the PMT. Take care to keep the filter and window lined up with the vertical grid visible within the tube.

#### **5.4.7 High Voltage Plate Adjustment**

If the plate voltage to the PMT is too high, a non-linearity problem will arise where gases in the midrange of the analyzer read higher than normal. If the plate voltage to the PMT is too low, the analyzer will run out of span adjustment on the front panel control. For this reason, the plate voltage to the PMT is critical.

Each new analyzer is tested with a range of gases to determine the optimum high plate voltage for the PMT. This voltage is adjustable through the potentiometer, labeled 1 P28 Plate Adjust on the rear panel of the analyzer. See Figure 1-2.

Adjust this voltage very carefully to eliminate non-linearity problems. It is normally only adjusted if you run out of span or zero adjustment on the front panel controls.

#### **5.4.8 High Voltage Transformer**

One of the most common failures of the analyzer is an open secondary winding in the high-voltage transformer. This transformer, powered by the 255 Hz power supply, supplies ionization voltage to the analytical cell. The value of high voltage coming from the transformer is difficult to measure, but an accurate reading is not necessary. To check the transformer:

1. Remove the AC power cord from the analyzer.
2. Measure resistance across the primary and secondary transformer windings. The nominal resistance readings of a good high-voltage transformer are 60 ohms across the primary winding and 47.2 K ohms across the secondary winding (output).

#### **5.4.9 Amplifier Board**

The amplifier board output is set at 0 to 100 mVDC at the time of installation. Check it by measuring the voltage across the terminal strip test point connections. See Figure 1-2. This reading varies with sample impurity level.

#### **5.4.10 Hamamatsu PMT High Voltage Supply**

The high voltage DC power for the PMT is supplied by a power supply that is integral with the PMT socket. The socket contains the high voltage supply, the resistor ladder for the intermediate dynodes in the PMT, and a 1.22 VDC reference voltage generator.

The socket works in conjunction with the 10-turn 10K variable potentiometer plate voltage adjustment on the back panel of the analyzer (see Figure 1-2) to provide the proper plate voltage to the PMT. The blue wire supplies a 1.22 VDC reference voltage to the plate adjustment potentiometer. This voltage is divided down by the potentiometer and a fraction of this voltage is sent back as a control voltage to the socket on the white wire. Both of these voltages can be measured on the back of the plate voltage adjustment potentiometer. The high voltage supply amplifies this control voltage 1000x. The raised voltage is then used by the PMT.

To check the system, proceed as follows:

1. Measure the +15 VDC supply to the socket at the test jack panel. See Figure 1-4.
2. If the +15 VDC measures correctly, measure the reference voltage on terminal 3 of the 1P28 potentiometer. It should measure  $1\ 223 \pm 5$  mV. Ground may also be found on the black wire on the potentiometer.
3. If the reference voltage measures correctly, measure the control voltage terminal 2 of the potentiometer. You should read a fraction of the reference voltage, depending on the plate voltage

setting on the potentiometer. For example, if the reference voltage measures 1.223 VDC and the plate voltage setting is 3.14, then the expected control voltage is:

$$0.314 \times 1.223 \text{ VDC} = 0.384 \text{ VDC}$$

If not, the plate voltage adjustment potentiometer is at fault.

If the control voltage measures correctly, remove the PMT from the socket (refer to section 5.4.6). Measure the voltage between pins 11 and 10 in the socket, with pin 10 being ground. You should measure 1000x the control voltage. Using the example above, you would measure 384 VDC. If you do not, the power supply is at fault and should be replaced.

#### **5.4.11 Low Voltage DC Supply Board**

The low voltage DC power supply comes from the 255 Hz power supply board. Output is set at +15 VDC and -15 VDC + 0.8 VDC at the time of installation. Check this by measuring the voltage at the test point panel across the green (-) to red (+) +15 VDC test jack and the green (-) to orange (+) -15 VDC test jacks.

#### **5.4.12 Regulated 255 Hz Power Supply**

The regulated 255 Hz power supply output is set at  $85 \pm 5$  VAC at the time of installation. Check this by measuring the voltage at the test point panel across the blue 90 VAC test jacks.

#### **5.4.13 Digital Panel Meter**

To replace the DPM, use the following procedure:

1. Remove the AC power cord from the analyzer.
2. Remove the analyzer cover.
3. Remove the DPM mounting bracket screws.
4. Loosen the terminal connections on the back of the DPM, noting the connections for installation of the new meter.
5. Remove the DPM by sliding it out through the front panel of the analyzer.
6. Replace the DPM, and re-connect the terminal strip wiring.

#### 5.4.14 Zero and Span Potentiometers

The zero and span potentiometers are located underneath the chassis next to the DPM (refer to Figure 1.3). Perform the following steps to replace the potentiometer:

1. Remove the AC power cord from the analyzer, and remove the cover for access to the zero and span potentiometers.
2. Unsolder the potentiometers to be replaced.
3. You will need two tools for removing the potentiometers: an Allen wrench for the set screw and a small double-ended screwdriver for the potentiometers base:
  - a. Loosen the set screw in potentiometer cover with the Allen wrench, and remove the potentiometer cover.
  - b. Loosen the potentiometer base with the screwdriver, and remove it.
  - c. Pull the potentiometer through the inside of the analyzer to remove.
4. Install the new potentiometer. Placement of the potentiometer components during installation will impact the range indication of the potentiometer. When installing the base, ensure that the white "tick mark" on the base remains on top. Turn the knob underneath the potentiometer cover fully counterclockwise before installing the cover. Adjust the potentiometer to a full zero reading before tightening the set screw.
5. Resolder the potentiometer.

## Appendix

---

### A.1 Specifications

Measurement Ranges: Model 2120A 0-2/0-20 ppm N<sub>2</sub> in Ar  
Model 2120B 0-20/0-200 ppm N<sub>2</sub> in Ar

Sample Flowrate: 2 cfh (0.88 slpm)

Operating Temperature: 60-95°F (16-35°C)

Max Pressure: 10 psig (69 kPa<sub>0</sub> at sample inlet  
6 psig (41 kPa) at analytical cell

Nominal Sample Inlet Pressure: 2-7 psig (14-48 kPa)

Power Required: Model 2120A: ~300 W, 120/230 VAC  
50/60 Hz  
Model 2120 B: ~100 W, 120/230 VAC  
50/60 Hz

Output: 4-20 mA  
Dry contacts for Range ID  
Dry contacts for Overrange Indication

Sample Connections: 1/4" VCR inlet  
1/4" Swagelok vent

Sensitivity: ± 0.01 ppm N<sub>2</sub> in Ar

Accuracy: ± 0.02 ppm N<sub>2</sub> in Ar on 0-2 ppm range  
± 0.25 ppm N<sub>2</sub> in Ar on 0-20 ppm range  
± 2.50 ppm N<sub>2</sub> in Ar on 0-200 ppm range

Dimensions: 5.25" H x 16.625" W x 14.625" D  
(13.34 cm H x 42.23 cm W x 37.15 cm D)

Weight: 25 lbs (11.3 kg)

## A.2 Recommended Replacement Parts List

Qty.	Part Number	Description
1	GM123-281	255 Hz Power Supply
1	GM123-282	4-20 mA Conversion Module
1	GM123-283	Amplifier Board
1	GM15-200	Analytical Cell
1	GM123-284	Brightness Sensor Board
2	GM121-139	Fuse, 2 amp 3AG (120 VAC)
2	GM121-142	Fuse, 1 amp 3AG (230 VAC)
1	GM127-571	Photomultiplier Tube
1	GM127-570	Hamamatsu PMT Socket
1	GM118-176	High Voltage Transformer
1	GM120-235	Low Flow Switch, Argon
1	GM147-121	N2 Filter (337 nm)
2	GM175-244	Orifice Gasket

A minimum charge is applicable to spare parts orders.

*Note: Orders for replacement parts should include the part number (if available) and the model and serial number of the instrument for which the parts are intended.*

Orders should be sent to:

**TELEDYNE Analytical Instruments**

16830 Chestnut Street  
City of Industry, CA 91749-1580

Phone (626) 934-1500, Fax (626) 961-2538

Web: [www.teledyne-ai.com](http://www.teledyne-ai.com)  
or your local representative.





## Index

---

- 1 P28 Plate Adjust, 47
- accuracy, 51
- address, 52
- alarm, 34
  - low flow, 1
  - overrange, 1
- amplifier board, 8, 15, 48
- analog output, 1, 51
- analog output module, 8, 15
- analytical cell, 7, 15, 45
- applications, 1
- calibration, 26, 32
- calibration gas, 31
- card cage, 7
- caution sign, iv
- cell holder, 46
- combustible gas warning, xi
- constant "1" display, 34
- control relay, 7, 44
- controls, 3
- copyright, ii
- dead space, 24
- digital panel meter. *See* display
- dimensions, 20, 51
- dirt, 37
- display, 1, 2, 4, 7, 49
- electric discharge, 15
- electrical connections, 21
- emergency response, 9
- emission, 1, 2, 15
- external sample system. *See* sample system
- factory calibration, 31
- figures listing, ix
- filter, 1, 2, 7, 15, 43
- flow control orifice. *See* orifice
- flow rate, 3
- flowmeter. *See* rotameter
- flowrate, 15, 51
- front panel, 3
- fuse, 42
- fuse holder, 7
- gas connections, 25
- Hamamatsu PMT socket, 7, 15, 48
- high voltage transformer, 7
- high-voltage transformer, 15, 47
- identification plate, 5
- impurity, 3
- indicator light, 2
- inlet connection, 24
- inlet line, 25
- installation, 19
- installation checklist, 27
- internal components, 6
- ionization, 16
- ionization voltage, 47
- label, 11
- leak check, 23
- line frequency interference, 15
- line voltage, 21, 42
- linear response, 31
- location, 20
- log, 37
- log form, 53
- low flow light, 3
- low flow switch, 3, 8, 44
- maintenance schedule, 37
- manuals, additional, v
- model information, iii
- moisture, 17
- molecular sieve, 31
- multimeter, 38
- negative display, 33
- nitrogen concentration, 1
- nitrogen-free argon, 31
- on-line light, 3
- operation, 29
- orifice, 7, 12, 16, 25
- output, 7, 15
- output conversion board, 7
- output frequency, 15
- overrange alarm contact, 5
- overrange alarm light, 3
- overrange protection alarm. *See* alarm overrange protection circuit, 16, 34
- overrange protection circuit test, 34

- ozone emission, 17
- photodiode, 16, 34
- photomultiplier tube. *See* PMT
- plate voltage, 15, 47
- PMT, 1, 2
- PMT cover, 7
- PMT replacement, 47
- PMT voltage adjustment, 5
- PMT voltage Adjustment, 2
- power entry module, 3, 4, 7, 42
- power light, 3
- power supply, 7, 15
  - high voltage, 48
  - low voltage, 49
- pressure, 12, 15, 16, 51
  - maximum, 12, 25
- purge, 12, 24
- purge flowrate, 26
- purge gas, 26
- purge time, 26
- rack mount, 15
- range, 1, 51
- range ID, 2, 5
- range switch, 2, 4, 30
- recorder contacts, 5
- reference voltage, 48
- reference voltage generator, 7
- regulator, 24
- rotameter, 2, 4, 8, 37
- routine maintenance, 37
- safety, 9
- safety guidelines, 10
- safety information, iv
- sample system, 15, 16, 23
- sample-in port, 4, 7
- sensitivity, 1, 51
- serial number, iii
- setpoint, 8
- shipping damage, 19
- socket. *See* Hamamatsu PMT socket
- span control, 2, 4, 8, 50
- span gas, 32
- span potentiometer. *See* span control
- spare parts listing, 52
- specifications, 51
- Swagelok fitting, 25
- tables listing, x
- technician symbol, iv
- Teledyne address, 52
- temperature, 51
- test jack, 1
- test jacks, 5, 8
- test point contacts, 5
- top cover, 6
- trace nitrogen, 1, 15
- troubleshooting, 38
- tubing, 24
- two-point calibration, 31
- VCR fitting, 2, 4, 24
- vent line, 25
- vent port, 5, 7
- warning sign, iv
- warranty, ii
- web address, 52
- website address, v
- weight, 51
- zero control, 2, 4, 8, 50
- zero gas, 31
- zero potentiometer. *See* zero control

